

CARCO®

PARTS MANUAL MODEL 50B PS FOR CATERPILLAR D4H & D5H PS TRACTORS

TABLE OF CONTENTS

	PAGE
Mounting Group	2
Control Group	4-5
Bevel Gear Group	6-7
Case and Covers	8-9
Clutch Shaft Group	10-11
Clutch Assembly	12
Brake Assembly	13
Manual Override (MOR) Brake Assembly	14-15
Idler Shaft Group — Without Freespool	16
Fourth Shaft Group	17
Idler Shaft Group — With Freespool	18-19
Drum Group	20-21
Hydraulic Control Group — Standard PTO	22-23
Pump Group and Accumulator	24
Control Valve	25
Control Stand	26
Fairlead	27
Control Cable Guard Group	28

MODEL

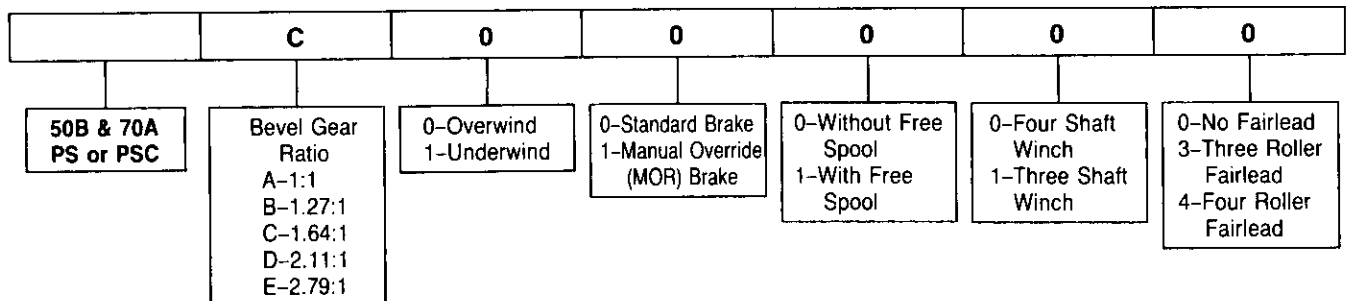

PACCAR WINCH DIVISIONS

**MODEL 50B PS
MOUNTING GROUP
CATERPILLAR D4H & D5H PS**

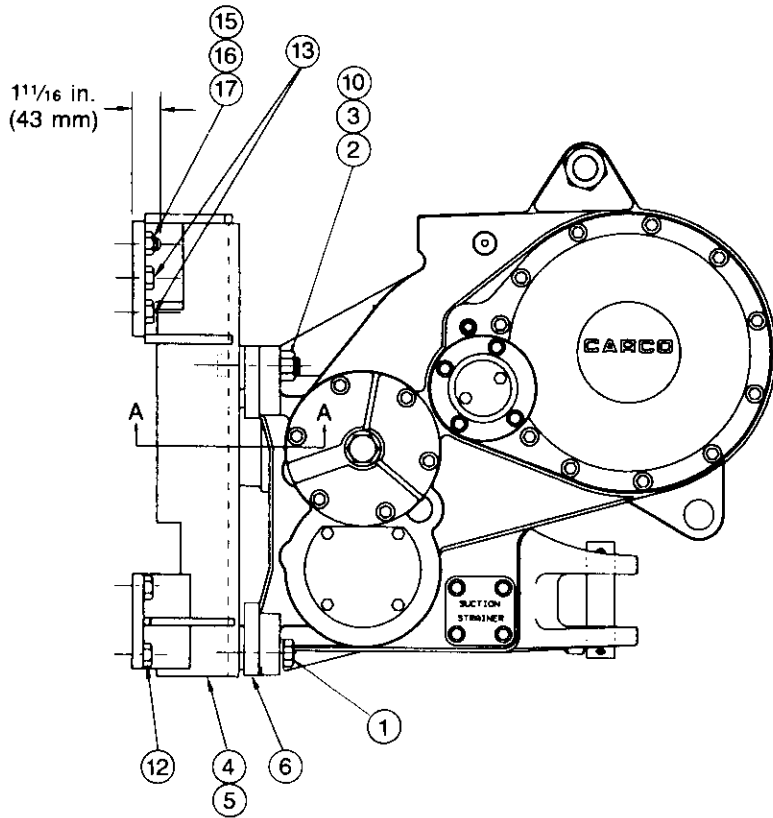

TRACTOR SHAFT (REF)

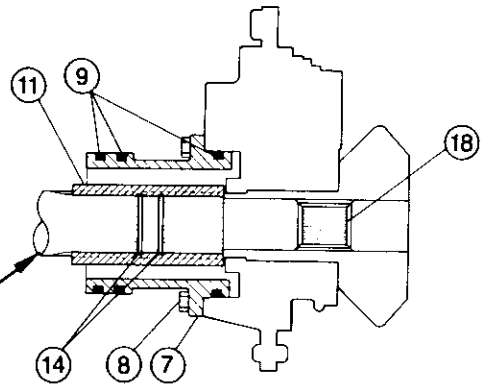

SECTION A-A

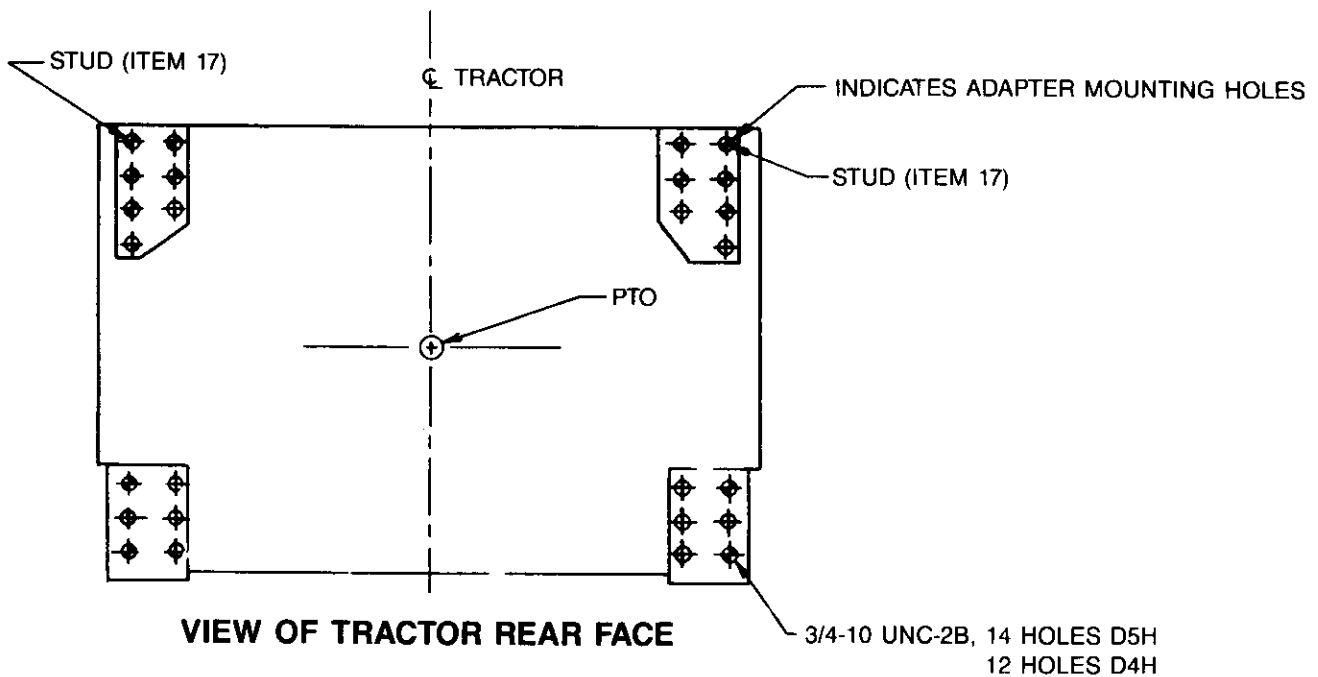

VIEW OF TRACTOR REAR FACE

INSTRUCTIONS

1. PTO rotation is counterclockwise (CCW) as viewed from rear of tractor.
2. Remove and discard tractor PTO cover.
3. Remove paint, rust, dirt and grease from mounting surfaces of tractor, winch and winch adapters.
4. Apply Loc-tite 271 to threads and install studs, Item 17, to a height of 1¹/₁₆ in. (43 mm) from tractor mounting surface.
5. Apply Loc-tite 271 to threads and install studs, item 3, into the winch adapter brackets to a height of 2.68 in. (68 mm) for D4H* and 3.68 (94 mm) for D5H.
6. Coat splines of PTO shaft, Item 18, with multi-purpose grease and install into bevel pinion gear of winch.
7. Install retaining rings, Item 14, in coupling, Item 11. Place coupling over PTO shaft with beveled end away from winch.
8. Install o-rings, Item 9, onto PTO pilot Item 7. Note: As the same PTO pilot may be used on several adaptations, usually only one o-ring groove will engage and seal in the tractor PTO opening.
9. Remove winch top cover to gain access to the bevel gears.

has adequate capacity. Failure to use adequate lifting equipment may result in property damage, personal injury or death.

10. Coat PTO pilot o-rings and splines of tractor PTO with multi-purpose grease and install winch on tractor while moving winch bevel gears to align the splines.

⚠ CAUTION

Fill winch to proper level with recommended oil BEFORE starting tractor. Bearing and gear damage may result if tractor or winch is run without oil.

11. Apply Loc-tite 242 to threads of studs, Item 3 and capscrews, Items 1, 12 & 13 and tighten as follows:
 - A) Method 1 – Tighten nuts to 960 lb•ft (1300 N•m).
 - Method 2 – Nuts to be snugged up to approximately 100 lb•ft (136 N•m) then mark position of nut and tighten an additional 2¹/₂ flats.
 - B) Capscrews, Item 1, to be tightened to 680 lb•ft (900 N•m) torque.
 - C) Capscrews, Items 12 & 13 to be tightened to 340 lb•ft (460 N•m).

⚠ WARNING

Winch and adapters weigh approximately 2,500 lb (1,135 kg). Make certain that lifting equipment

ITEM	PART NO.	DESCRIPTION	QTY.	
			D4H*	D5H
1	69970	CAPSCREW, HEX HEAD (1 - 8 × 2 ¹ / ₂ G8)	4	—
	31037	CAPSCREW, HEX HEAD (1 - 8 × 3 ¹ / ₂ G8)	—	4
2	70768	NUT (1 ¹ / ₈ - 7)	4	4
3	100654	STUD (1 ¹ / ₈ - 7 × 4 ³ / ₄ G8)	4	—
	100655	STUD (1 ¹ / ₈ - 7 × 5 ³ / ₄ G8)	—	4
4	100049	ADAPTER — RH	1	1
5	100050	ADAPTER — LH	1	1
6	69053	SPACER	—	4
7	69089	PILOT, PTO	1	1
8	22697	CAPSCREW, HEX HEAD (1/2 - 13 × 1 G5)	4	4
9	69850	O-RING	3	3
10	27803	WASHER (1 ¹ / ₈ HARDENED)	4	4
11	69056	COUPLING	1	1
12	31033	CAPSCREW, HEX HEAD (3/4 - 10 × 1 ³ / ₄ G8)	4	4
13	70691	CAPSCREW, HEX HEAD (3/4 - 10 × 2 G8)	6	8
14	68870	RETAINING RING	2	2
15	22885	NUT (3/4 - 10)	2	2
16	13824	WASHER (3/4)	2	2
17	33440	STUD (3/4 - 10 × 2 ⁵ / ₈ G8)	2	2
18	68807	PTO SHAFT	1	1

*D4H SERIES III LGP & XL USE D5H MOUNTING COMPONENTS.

**MODEL 50B PS
CONTROL GROUP
CATERPILLAR D4H & D5H PS**

DIM.	WITH FREESPOOL	WITHOUT FREESPOOL
"A"	9.50 (241 mm)	10.0 (254 mm)
"B"	7.13 (181 mm)	6.13 (156 mm)

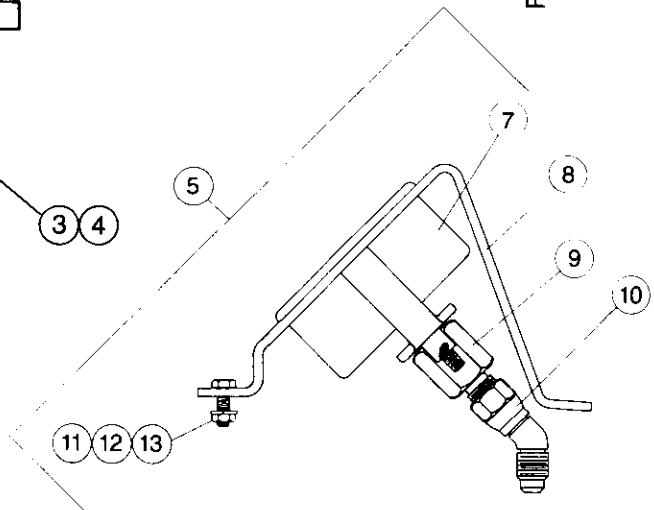
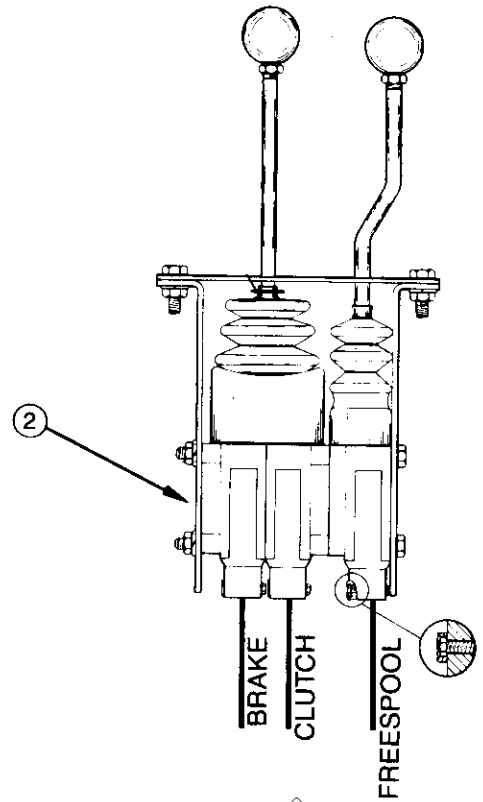
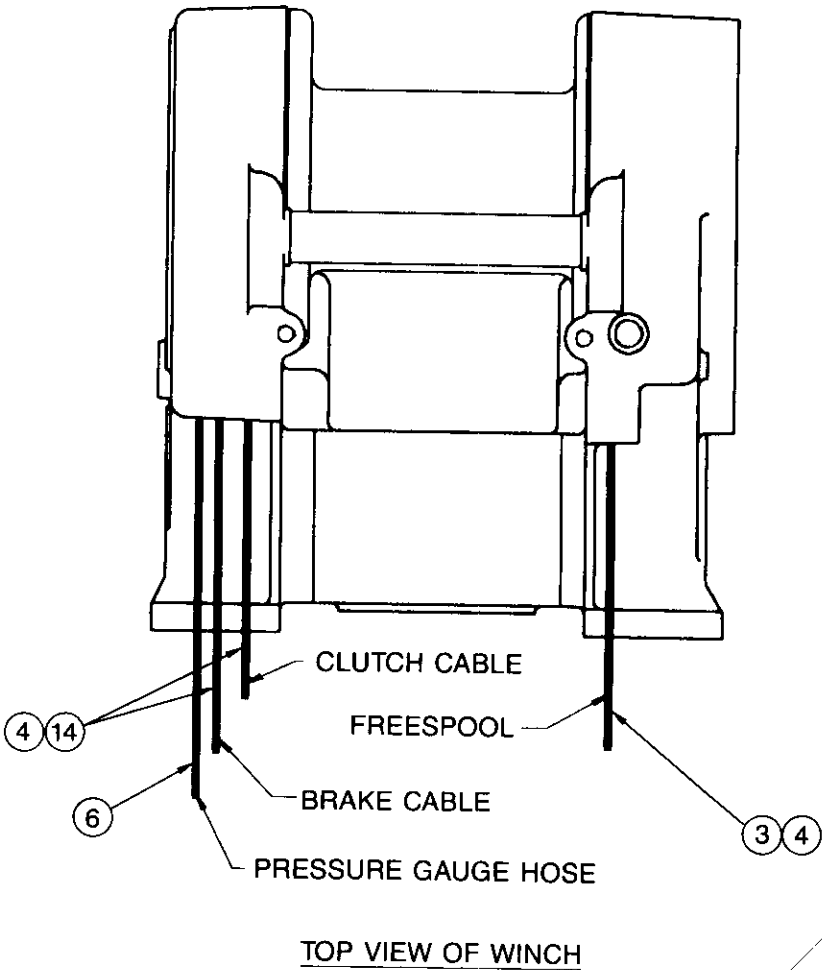
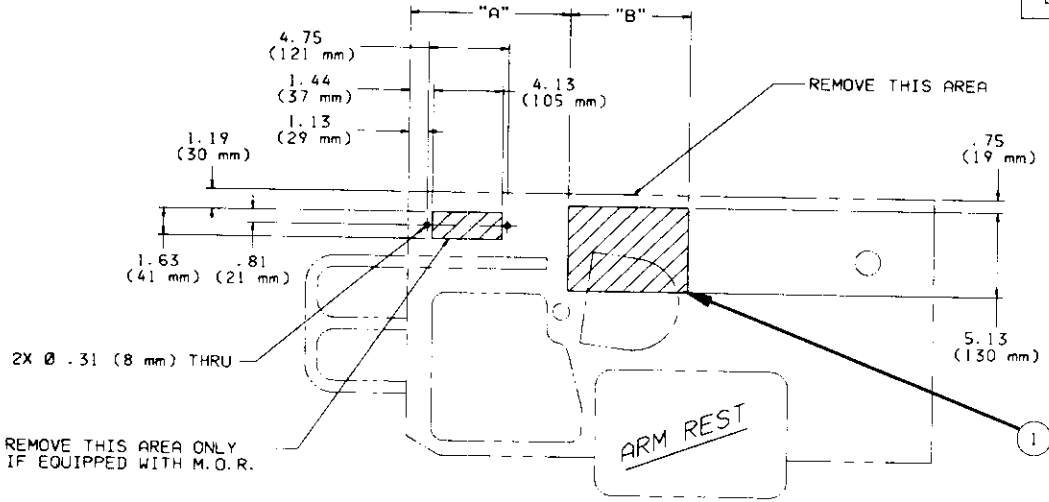

CONTROL INSTALLATION INSTRUCTIONS:

Note: These instructions are provided as a general guide. Tractor options, application requirements or local regulations may require deviation from these recommendations.

1. Modify tractor right hand console and ripper control cover plate as shown.
2. Remove 1.63 × 4.13 in. (41 × 105 mm) shaded area **ONLY** if equipped with manual override, MOR, brake option.
3. Carefully route control cables, filter light wire, and pressure gauge hose from winch to underside of right hand console.

⚠ CAUTION

Avoid routing cables near moving shafts or linkage which may cause damage to cables or restrict free movement of tractor components.

4. Pass cables up through control frame to control stand. Install cables to control stand as shown. Temporarily mount control stand in control frame. Position control frame in modified console such that the control cables will not interfere with any tractor control linkage, valves or tubes. Tack weld control frame to console.

5. Remove control stand from control frame. Finish welding control frame to console. Paint over welds as required.
6. Install filter indicator light assembly into control stand gate plate. Free end of wiring harness must be supplied with 12 to 24 volt-dc. The circuit is grounded through the filter bypass sending unit in the winch.
7. Refer to the MOR brake section, pages 14 and 15, of this manual for MOR piping instructions.
8. Securely install control stand into control frame. Secure cables, gauge hose and light wire with plastic tie straps as required to prevent chaffing.
9. Mount the pressure gauge in clear view of the operator.
10. Fill winch to proper level with recommended oil. Refer to oil specifications found on page 10 of the Operators Manual.
11. Verify proper control cable and pressure adjustment by following the procedures found on pages 8-10 of the Operators Manual.

ITEM	PART NO.	DESCRIPTION	QTY.	
			D4H	D5H
1	25696	CONTROL FRAME — WITH FREESPOOL	1	1
	28833	CONTROL FRAME — WITHOUT FREESPOOL	1	1
2	69667	CONTROL STAND - WITH FREESPOOL (SHOWN) REF. PG. 26	1	1
	81965	CONTROL STAND - WITHOUT FREESPOOL - REF. PG. 26	1	1
3	69800	CONTROL CABLE - 90 in. (2286 mm)	—	1
4	69801	CONTROL CABLE - 84 in. (2134 mm)	1	2
5	62058	PRESSURE GAUGE KIT (INCLUDES ITEMS 6-13)	1	1
6	34196	HOSE, GAUGE - 4, 96 in. (2438 mm)	1	1
7	27673	PRESSURE GAUGE	1	1
8	27651	BRACKET	1	1
9	27652	ADAPTER - 1/4 NPT - 4	1	1
10	70122	UNION 45° - 4	1	1
11	27683	CAPSCREW, HEX HEAD (5/16 - 18 × 1 1/4 G5)	2	2
12	69640	WASHER (5/16)	2	2
13	69644	NUT (5/16 - 18)	2	2
14	69802	CONTROL CABLE - 78 in. (1981 mm)	2	—

**MODEL 50B PS
BEVEL GEAR GROUP
CATERPILLAR D4H & D5H PS**

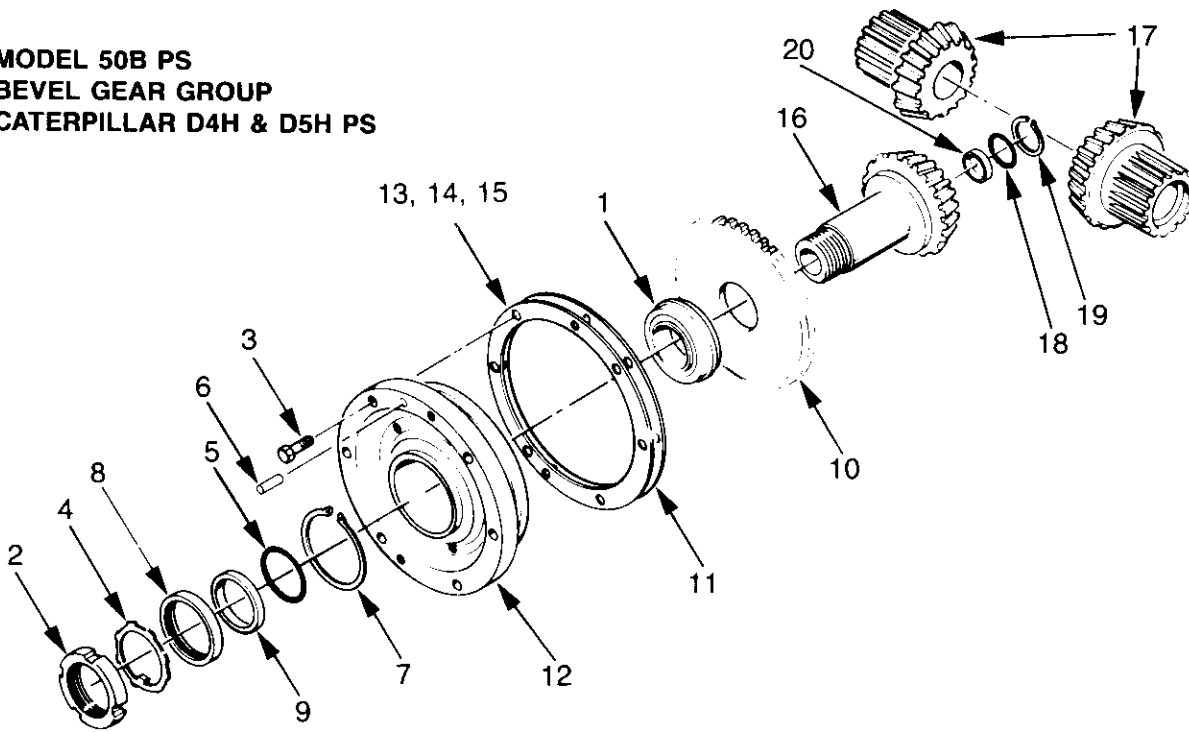

ITEM	PART NO.	DESCRIPTION	QTY.
1	70077	BEARING ASSEMBLY	1
2	24816	BEARING, LOCK NUT	1
3	22697	CAPSCREW HEX HEAD	6
4	11418	LOCKWASHER	1
5	74992	O-RING	1
6	10318	DOWEL PIN	1
7	70163	RETAINING RING	1
8	70168	OIL SEAL	1
9	70382	SEAL SPACER	1
10	69947	PUMP DRIVE PINION	1
11	69946	SHIM GASKET	1
12	69961	CARRIER	1
13	69945	SHIM .005"	2-AR
14	69827	SHIM .007"	2-AR
15	69826	SHIM .020"	2-AR
16	70354	BEVEL PINION - STANDARD SPEED - 3 SHAFT	1
	70355	BEVEL PINION - SLOW SPEED - 4 SHAFT	1
17	70352	BEVEL GEAR - STANDARD SPEED - 3 SHAFT	2
	70353	BEVEL GEAR - SLOW SPEED - 4 SHAFT	2
18	70133	O-RING	1
19	70161	RETAINING RING	1
20	70357	PLUG, BEVEL PINION	1

BEVEL GEAR SET LISTINGS

NOTE: The Bevel Gear Set above is standard for the adaption indicated. Below are gear combinations to provide a range of line speeds and pulls for various winching requirements. Important — Prior to ordering or quoting on any optional Bevel Gear Set be sure to check with factory on availability, and if the gear set would be recommended for the application.

BEVEL GEAR SET PART NO.	BEVEL GEAR		BEVEL PINION		RATIO			
	PART NO.	TEETH	PART NO.	TEETH	CODE	GEAR SET	OVERALL	
							3 SHAFT	4 SHAFT
36638	69821	30	36610	30	A	1:1	22.3:1	40.4:1
70449	70350	33	70373	26	B	1.27:1	28.3:1	51.4:1
70450	70351	36	70372	22	C	1.64:1	36.6:1	66.3:1
70451	70352	38	70354	18	D	2.11:1	47.0:1	85.3:1
70812	70353	39	70355	14	E	2.78:1	62.2:1	112.8:1

THIS PAGE INTENTIONALLY
LEFT BLANK.

WINCH CASE & COVERS

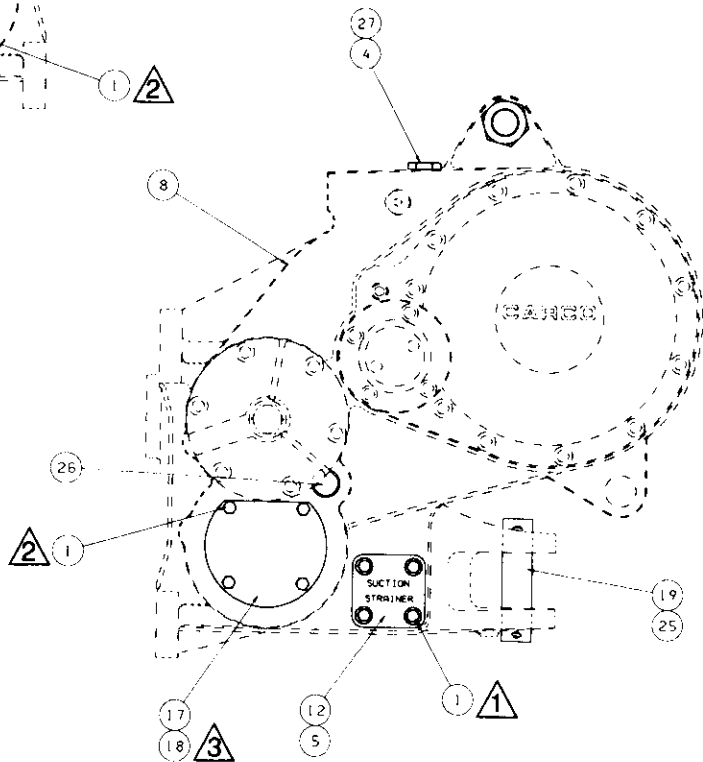
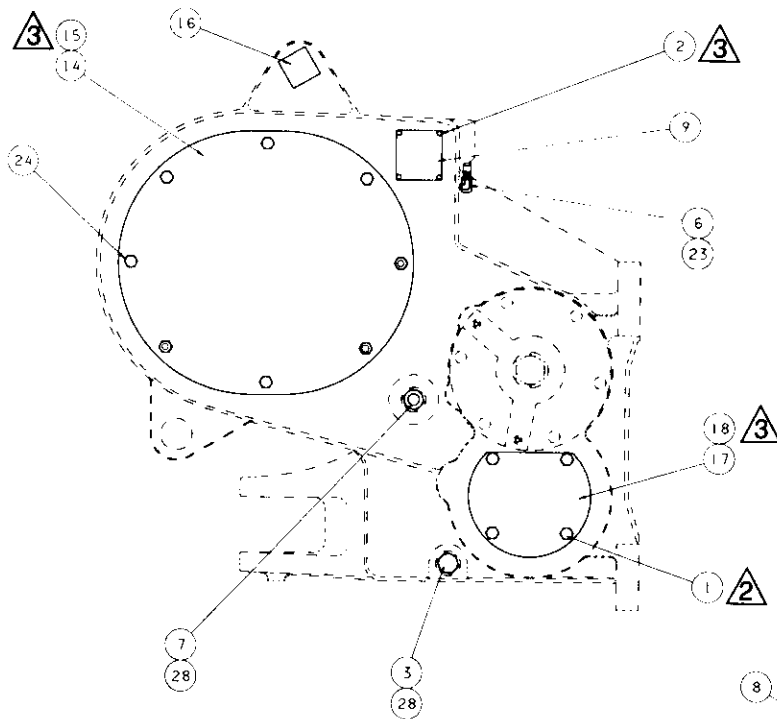
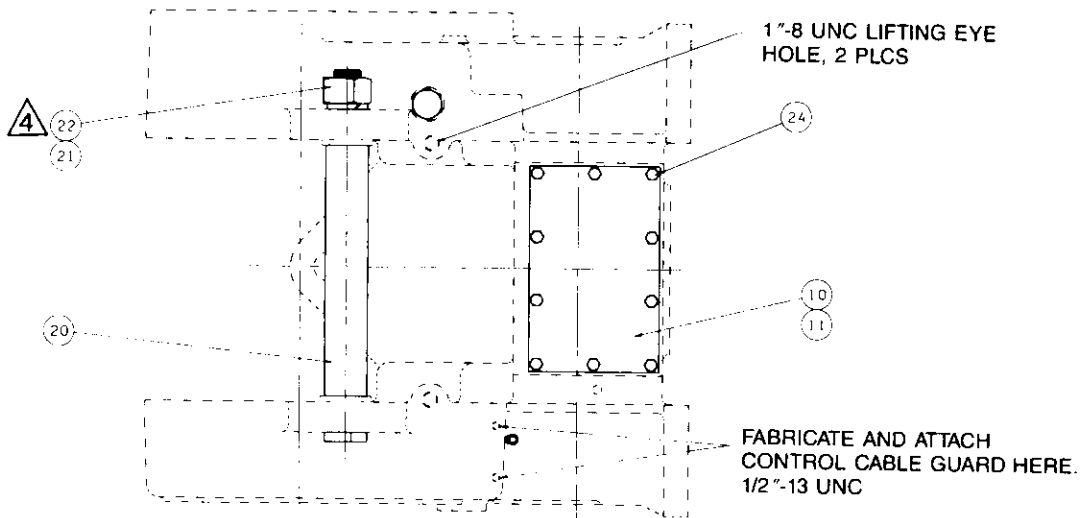

NOTES:

- 1 APPLY "FEL-PRO C-648F" TO BOLTS TO PREVENT THREAD CORROSION.
- 2 TIGHTEN FASTENERS TO 75 LB-FT (10.4 KgM) TORQUE.
- 3 APPLY "RTV 732" SILASTIC SEALANT TO BOTH SIDES OF GASKETS (ITEMS 11, 15 & 18) AND DRIVE SCREWS (ITEM 2).
- 4 TIGHTEN HEX NUT (ITEM 22) UNTIL LOCKWASHER (ITEM 21) IS FLATTENED AND THEN TURN ONE FLAT.

WINCH CASE & COVERS

ITEM	PART NO.	DESCRIPTION	QTY
1	22697	CAPSCREW, HEX HEAD (1/2 - 13 NC x 1 G5)	12
2	70053	DRIVE SCREW	4
3	70118	PLUG, DRAIN (MAY BE SUBSTITUTED FOR ITEM 7)	1
4	70119	PLUG, OIL FILL (INCLUDES ITEM 27)	1
5	22586	O-RING	1
6	11106	VENT PLUG	1
7	70193	SIGHT GAUGE (INCLUDES ITEM 28)	1
8	27752	WINCH CASE - STANDARD PTO - SHOWN	1
9	69533	SERIAL NUMBER DATA PLATE	1
10	27805	COVER, TOP ACCESS	1
11	27806	GASKET	1
12	70305	STRAINER COVER	1
14	69951	COVER, SIDE ACCESS	1
15	69950	GASKET	1
16	28772	TIE BOLT	1
17	27807	COVER, LOWER ACCESS	2
18	27808	GASKET	2
19	36618	DRAW BAR PIN	1
20	27804	SPACER TUBE	1
21	27666	LOCKWASHER, 1 3/4	1
22	27655	NUT, HEX HEAD (1 3/4 NC)	1
23	13708	ELBOW	2
24	27745	CAPSCREW, HEX HEAD (1/2 - 13 NC x 1 G5 SS)*	15
25	70148	COTTER PIN (3/8 x 3 in.)	2
26	70191	EXPANSION PLUG - 3 SHAFT WINCH ONLY	1
27	31608	O-RING - FOR OIL FILL PLUG	1
28	31607	O-RING - FOR OIL LEVEL & DRAIN PLUG	2

*SS = SELF SEALING MATERIAL PREAPPLIED TO THREADS

CLUTCH SHAFT GROUP

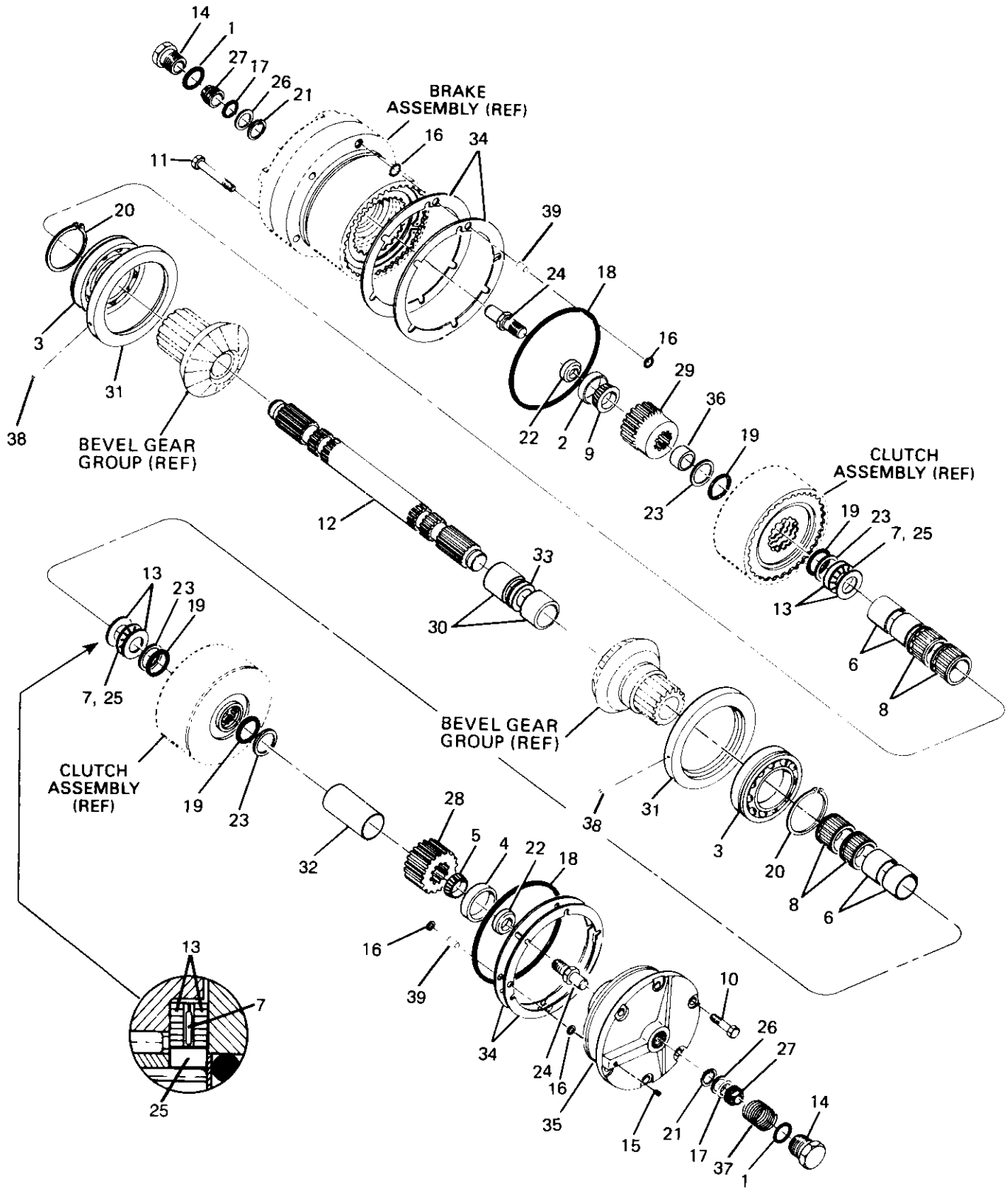

CLUTCH SHAFT GROUP

ITEM	PART NO.	DESCRIPTION	QTY
1	31608	O-RING (PART OF ITEM 14)	2
2	18049	BEARING CUP	1
3	70073	BALL BEARING — STD PTO	2
	70074	BALL BEARING, SHIELDED — LOW PTO	2
4	70075	BEARING CUP	1
5	70076	BEARING CONE	1
6	70083	NEEDLE BEARING — INNER RACE	4
7	11891	THRUST BEARING	2
8	70084	NEEDLE BEARING	4
9	18048	BEARING CONE	1
10	22697	CAPSCREW, HEX HEAD (1/2 - 13 NC x 1 G5)	6
11	24710	CAPSCREW, HEX HEAD (1/2 - 13 NC x 3 G5)	6
12	69997	CLUTCH SHAFT — 4 SHAFT WINCH	1
	69597	CLUTCH SHAFT — 3 SHAFT WINCH	1
13	11892	THRUST BEARING RACE	4
14	70119	PLUG (CONTAINS ITEM 1)	2
15	70120	PLUG (1/4 NPT)	1
16	72097	O-RING	8
17	18170	O-RING	2
18	21833	O-RING	2
19	25023	O-RING	4
20	70158	RETAINING RING	2
21	70160	RETAINING RING	2
22	70361	BEARING RETAINER	2
23	25024	BACK-UP RING	4
24	70364	ROTARY SEAL SHAFT	2
25	70379	THRUST BEARING SPACER	2
26	70333	BACK-UP WASHER	2
27	70334	ROTARY SEAL	2
28	69991	PINION GEAR — 18 TEETH - 4 SHAFT WINCH	1
	70291	PINION GEAR — 15 TEETH - 3 SHAFT WINCH	1
29	70292	BRAKE HUB	1
30	69690	BEVEL GEAR SPACER	2
31	70376	BEARING CARRIER	2
32	69983	PINION SPACER — 4 SHAFT WINCH	1
	69045	PINION SPACER — 3 SHAFT WINCH	1
33	70247	SHIM SET	1
34	27844	SHIM .005	AR
	27845	SHIM .007	AR
	27846	SHIM .020	AR
35	27850	CLUTCH SHAFT BEARING CAR. — 4 SHAFT WINCH	1
	27853	CLUTCH SHAFT BEARING CAR. — 3 SHAFT WINCH	1
36	69045	BRAKE HUB SPACER	1
37	70332	SPRING (NOT USED ABOVE S/N 9302136)	1
38	75267	ROLLPIN	2
39	70358	SLEEVE	4

AR — AS REQUIRED

CLUTCH ASSEMBLY

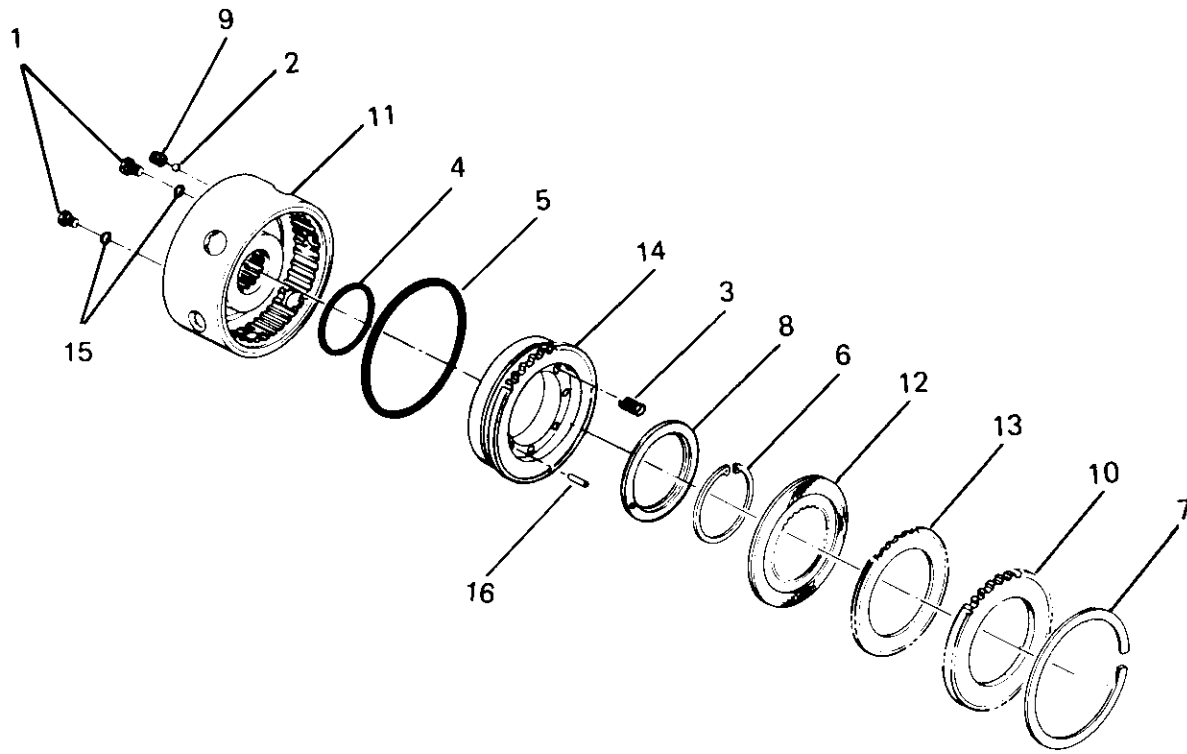

ITEM	PART NO.	DESCRIPTION	QTY
—	81968	CLUTCH ASSEMBLY — INCLUDES ITEMS 1-16	
1	70177	PLUG, O-RING FLUSH — INCLUDES ITEM 15	2
2	70126	STEEL BALL	1
3	70130	SPRING	8
4	77367	O-RING	1
5	22357	O-RING	1
6	70170	RETAINING RING	1
7	26147	RETAINING RING	1
8	70328	SPRING RETAINER	1
9	70241	CHECK VALVE SEAT	1
10	26755	PRESSURE PLATE	1
11	28866*	CLUTCH HOUSING	1
12	70636	DISC — FRICTION, BRONZE	5
13	27861	DISC — STEEL .093 in. (2.36 mm)	4
14	70306	CLUTCH PISTON	1
15	70724	O-RING	2
16	70862	PIN	1

*Part No. 28866 includes Housing 70299 with two (2) steel balls 70126 driven into drilled passages.

BRAKE ASSEMBLY - STANDARD

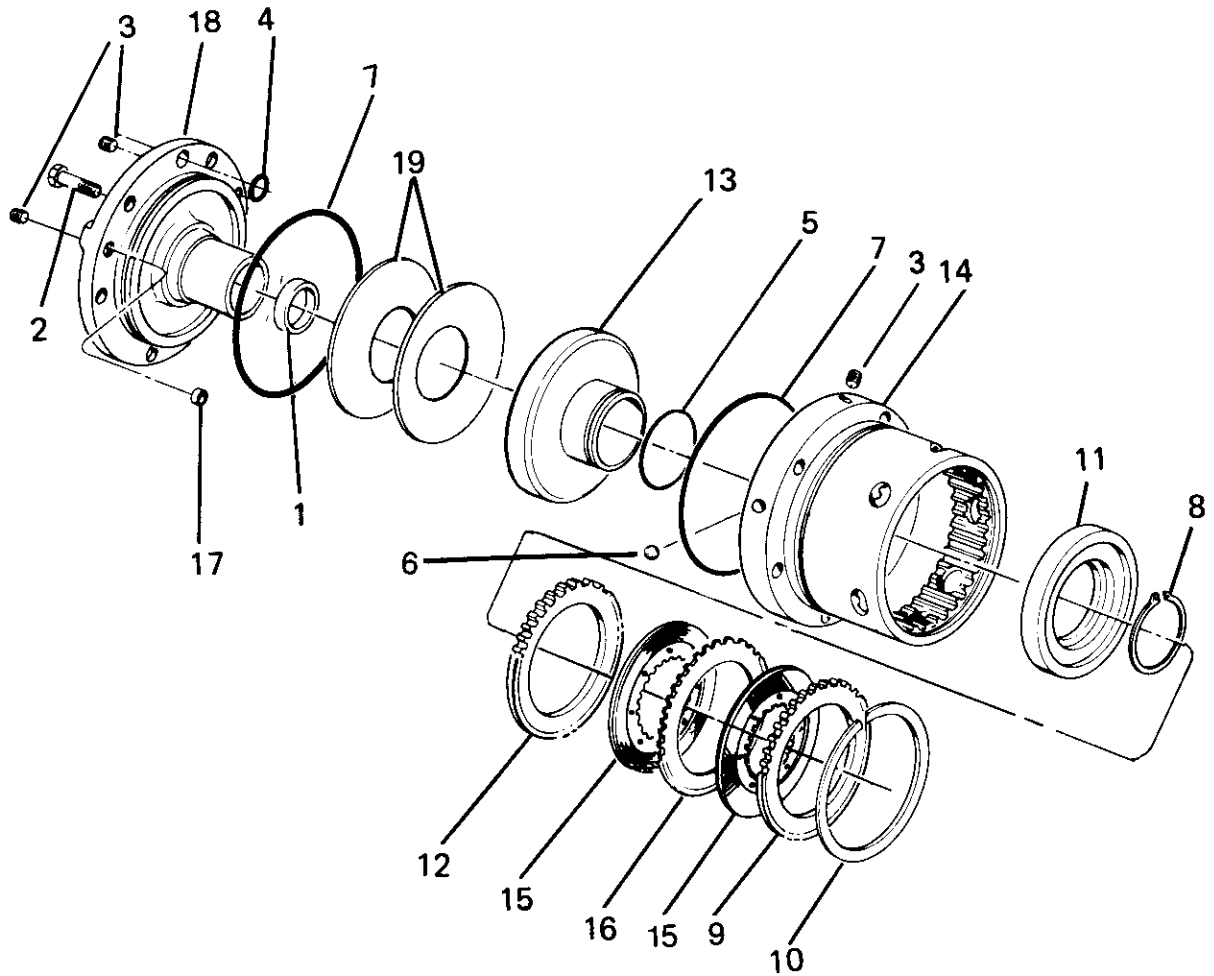

ITEM	PART NO.	DESCRIPTION	QTY
—	81960	BRAKE ASSEMBLY, STD — INCLUDES ITEMS 1-20	
1	18049	BEARING CUP	1
2	21961	CAPSCREW, HEX HEAD (3/8 - 16 NC × 1 G5)	2
3	70120	PLUG, HEX SOCKET (1/4 NPT)	4
4	22454	O-RING	3
5	10330	O-RING	1
6	70126	STEEL BALL	2
7	22358	O-RING	2
8	69807	RETAINING RING	1
9	26755	PRESSURE PLATE — OUTER	1
10	26147	RETAINING RING	1
11	69976	PISTON RETAINER	1
12	70293	PRESSURE PLATE — INNER	1
13	69921	BRAKE PISTON	1
14	27841	BRAKE HOUSING (REQUIRES 2 OF ITEM 6)	1
15	70636	DISC — FRICTION BRONZE	8
16	27861	DISC STEEL — .093 in. (2.36 mm)	7
17	27843	INSERT	1
18	69994	BRAKE CARRIER	1
19	70255	BRAKE SPRING	2

**MANUAL OVERRIDE (MOR)
BRAKE ASSEMBLY**

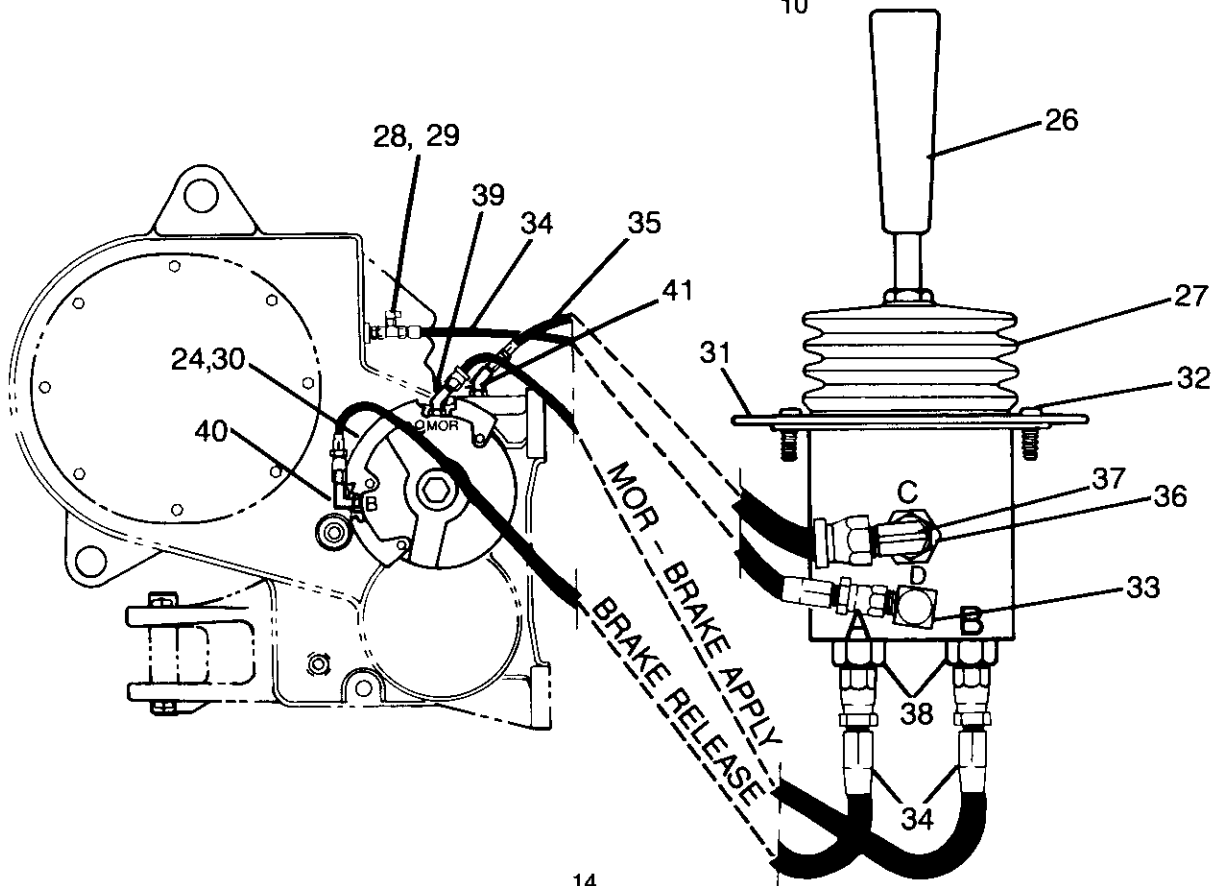
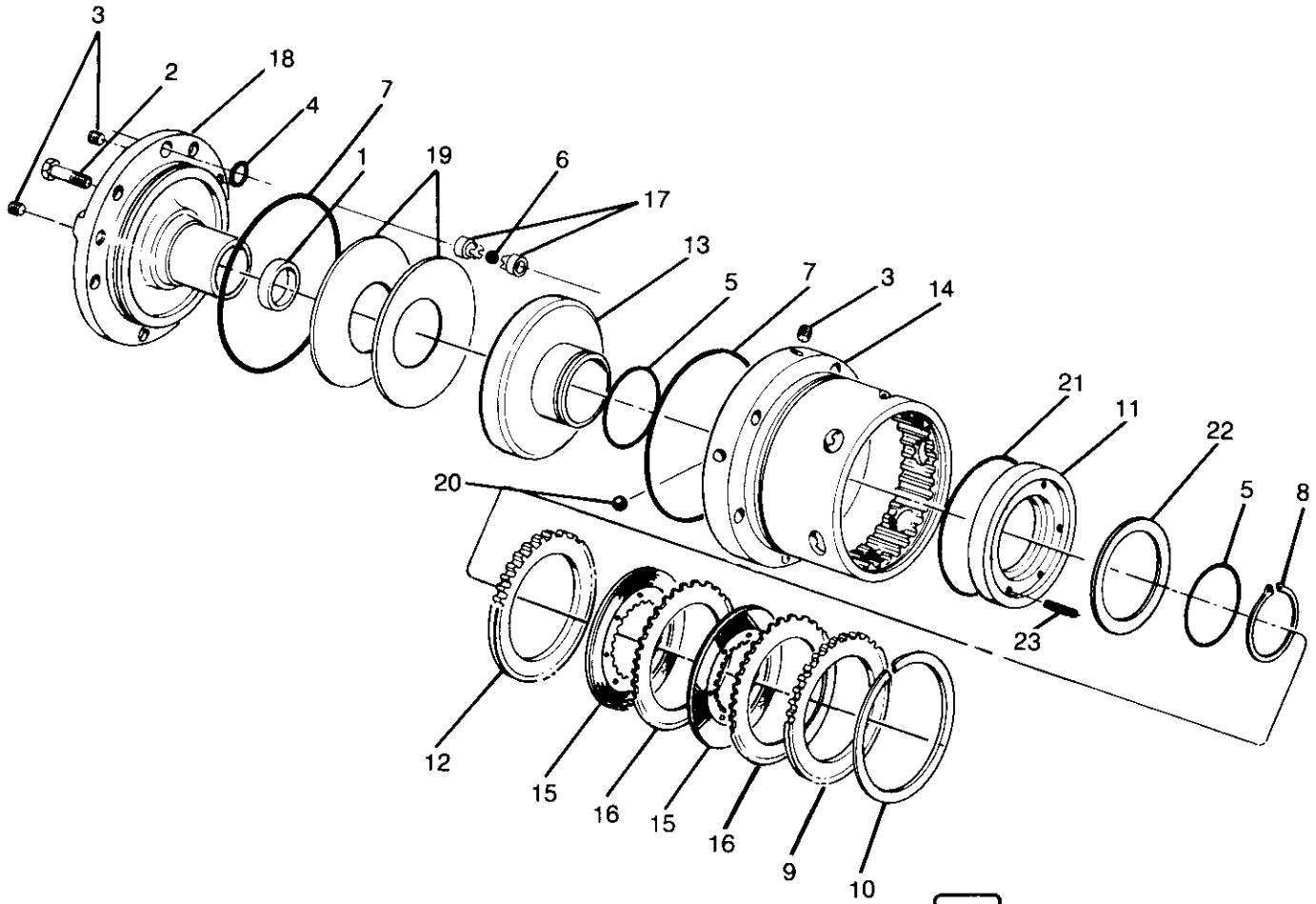

**MANUAL OVERRIDE (MOR)
BRAKE ASSEMBLY**

ITEM	PART NO.	DESCRIPTION	QTY
—	81961	BRAKE ASSEMBLY, MOR — INCLUDES ITEMS 1-23	
1	18049	BEARING CUP	1
2	21961	CAPSCREW, HEX HEAD	2
3	70120	PLUG, HEX SOCKET	3
4	22454	O-RING	3
5	10330	O-RING	2
6	12102	STEEL BALL	1
7	22358	O-RING	2
8	69807	RETAINING RING	1
9	26755	PRESSURE PLATE — OUTER	1
10	26147	RETAINING RING	1
11	69925	OVERRIDE PISTON	1
12	70293	PRESSURE PLATE — INNER	1
13	69921	BRAKE PISTON	1
14	27841	BRAKE HOUSING	1
15	70636	DISC — FRICTION BRONZE	8
16	27861	DISC — STEEL - .093 in. (2.36 mm)	7
17	27842	BALL GUIDE	2
18	69994	BEARING CARRIER	1
19	70255	BRAKE SPRING	2
20	70126	STEEL BALL	2
21	10450	O-RING	1
22	69924	SPRING RETAINER	1
23	69627	SPRING	6
24	69317	HOSE GUARD	1
25	69511	CONTROL VALVE (DOES NOT INCLUDE HANDLE)	1
26	26691	HANDLE	1
27	26692	BOOT	1
28	26002	SWIVEL TEE	1
29	70123	UNION 90° - 4	1
30	11073	WASHER	4
31	69513	DATA PLATE	1
32	11047	CAPSCREW, HEX HEAD	2
33	31348	ELBOW — 90° VALVE D PORT	1
34	70194	HOSE ASSEMBLY — PRESSURE	3
35	69499	HOSE ASSEMBLY — DRAIN	1
36	31286	ADAPTER VALVE C PORT	1
37	31426	UNION, 90° MALE VALVE C PORT	1
38	31284	ADAPTER	2
39	31333	ELBOW, 45° ¼ NPT - 4	1
40	31341	ELBOW, 90° ¼ NPT - 4	1
41	31335	ELBOW, 45° ⅜ NPT - 6	1

**IDLER SHAFT GROUP
WITHOUT FREESPOOL**

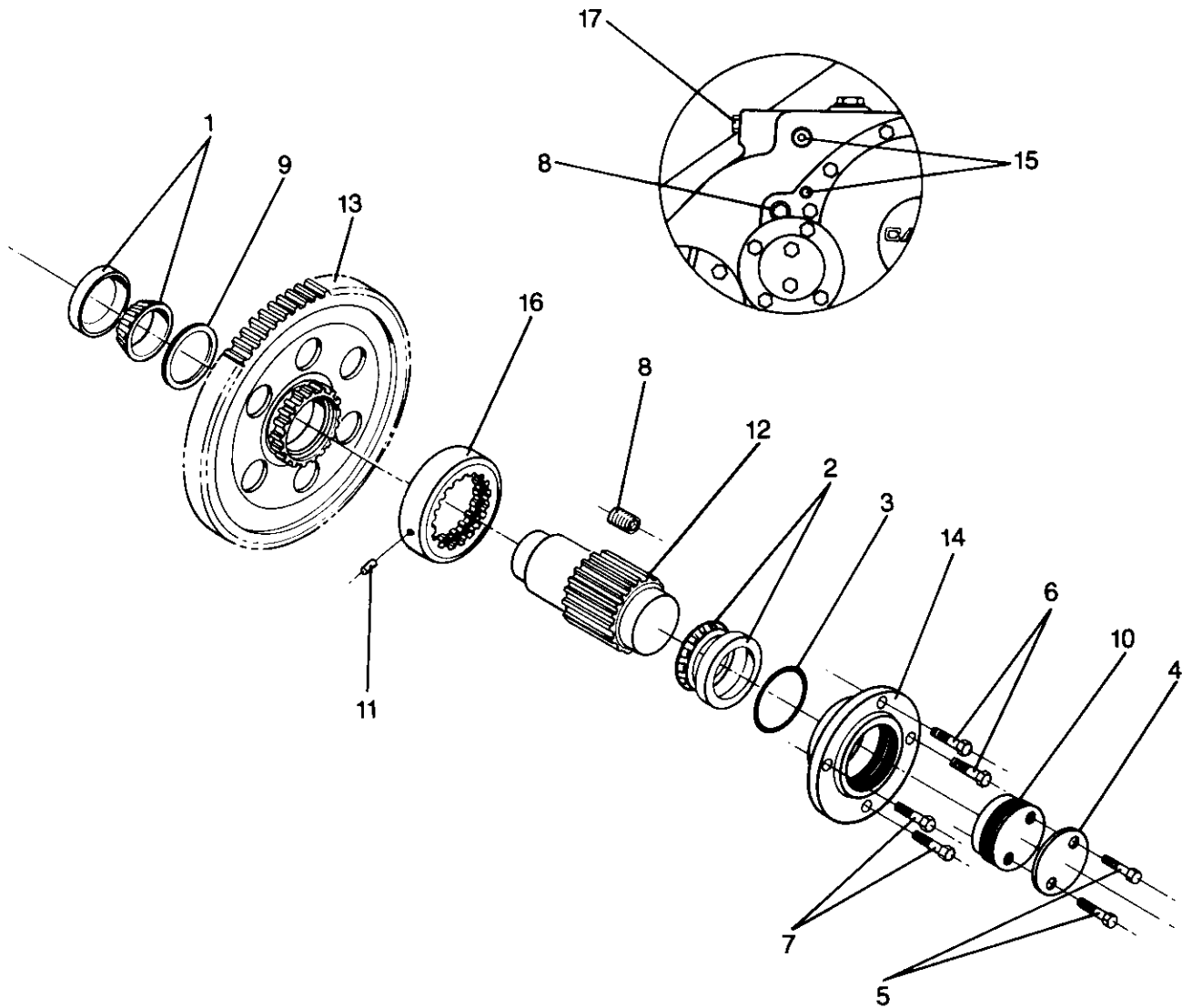

ITEM	PART NO.	DESCRIPTION	QTY.
1	69013	BEARING ASSEMBLY — INNER	1
2	69014	BEARING ASSEMBLY — OUTER	1
3	25880	O-RING	1
4	69655	LOCK PLATE	1
5	22729	CAPSCREW, HEX HEAD (1/2 - 13 x 3/4 G5)	2
6	22697	CAPSCREW, HEX HEAD (1/2 - 13 x 1 G5)	2
7	13421	CAPSCREW, HEX HEAD (1/2 - 13 x 2 G5)	2
8	27216	PLUG, SOCKET HEAD	1
9	11892	THRUST WASHER	1
10	69592	ADJUSTER	1
11	11836	ROLLPIN	1
12	69984	PINION, SECOND REDUCTION	1
13	27320	GEAR, FIRST REDUCTION	1
14	69974	CARRIER, IDLER SHAFT	1
15	25915	SCREW, SOCKET HEAD	2
16	69977	COLLAR	1
17	69782	CAPSCREW HEX HEAD (3/4 - 16 x 1 1/4 G5)	1

FOURTH SHAFT GROUP

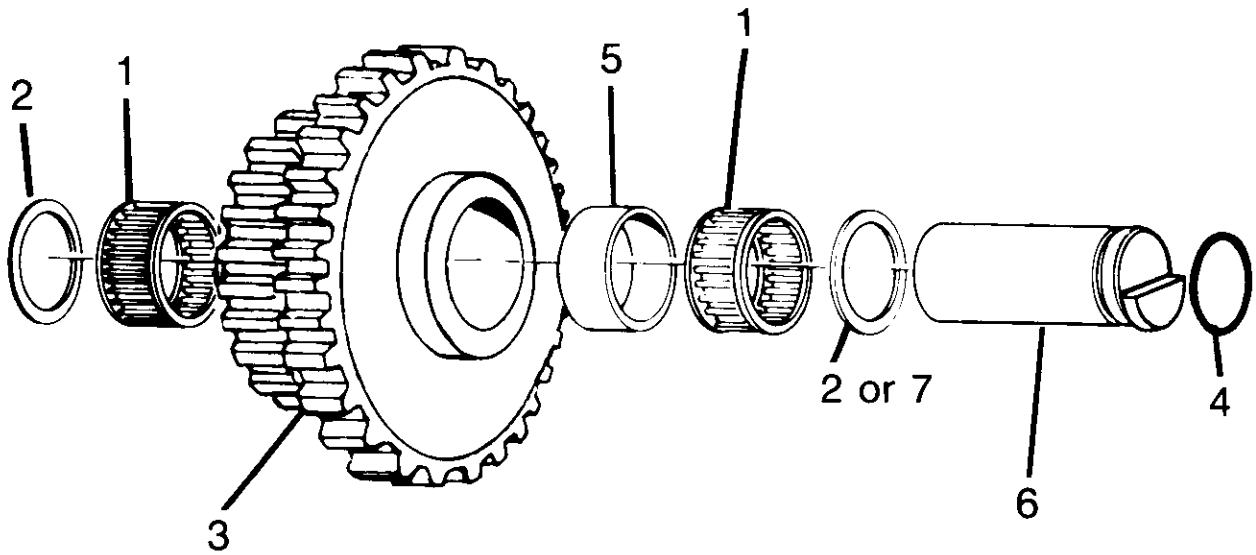

FOR WINCH SERIAL NO. 9002141 TO 9002160 AND 9004003 AND UP.

ITEM	PART NO.	DESCRIPTION	QTY
1	70648	ROLLER BEARING	2
2	24581	THRUST WASHER .062 in. (1.58 mm)	1
3	28925	CLUSTER GEAR 37/17 TEETH	1
4	13838	O-RING	1
5	28926	SPACER	1
6	69673	COUNTERSHAFT PIN	1
7	28924	THRUST WASHER .217 in. (5.5 mm)	1

FOR WINCH SERIAL NO. BUILT PRIOR TO 9004003, EXCEPT 9002141 TO 9002160.

ITEM	PART NO.	DESCRIPTION	QTY
1	70648	ROLLER BEARING	2
2	24581	THRUST WASHER .062 in. (1.58 mm)	2
3	69985	CLUSTER GEAR 37/17 TEETH **	1
4	13838	O-RING	1
5	70342	SPACER	1
6	69673	COUNTERSHAFT PIN	1

**IF REPLACING CLUSTER GEAR 69985 ON EARLY MODEL 70 or 70A, ORDER QTY. 1 OF 28925 CLUSTER GEAR, QTY. 1 OF 28926 SPACER AND QTY. 1 OF 28924 THRUST WASHER.

**IDLER SHAFT GROUP
WITH FREESPOOL**

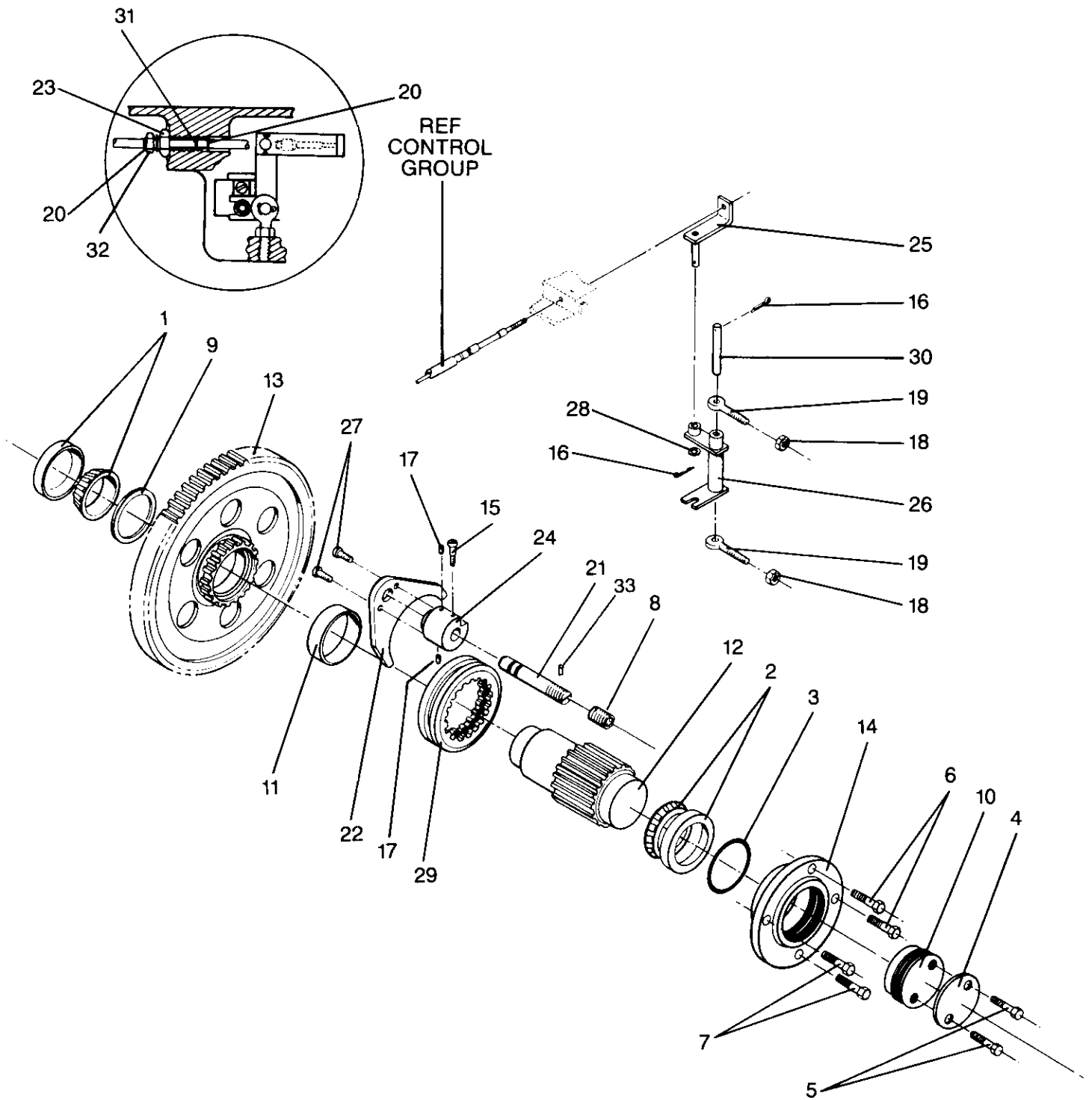

**IDLER SHAFT GROUP
WITH FREESPOOL**

ITEM	PART NO.	DESCRIPTION	QTY.
1	69013	BEARING ASSEMBLY -- INNER	1
2	69014	BEARING ASSEMBLY -- OUTER	1
3	25880	O-RING	1
4	69655	LOCK PLATE	1
5	22729	CAPSCREW, HEX HEAD (1/2 - 13 x 3/4 G5)	2
6	13938	CAPSCREW, HEX HEAD (1/2 - 13 x 1 1/4 G5)	2
7	13421	CAPSCREW, HEX HEAD (1/2 - 13 x 2 G5)	2
8	27216	PLUG, SOCKET HEAD	1
9	11892	THRUST WASHER	1
10	69592	ADJUSTER	1
11	70349	BUSHING	1
12	69984	PINION, SECOND REDUCTION	1
13	69980	GEAR, FIRST REDUCTION	1
14	69974	CARRIER, IDLER SHAFT	1
15	70166	SHOULDER SCREW	1
16	70861	COTTER PIN	2
17	70136	BALL PLUNGER	2
18	18004	JAM NUT	2
19	70370	ROD END	2
20	69653	RETAINING RING	2
21	81921	SHIFT RAIL, INCLUDES ITEM 33	1
22	70348	YOKE	1
23	11059	JAM NUT	1
24	69263	SHIFT COLLAR	1
25	70652	CABLE CONNECTOR	1
26	69262	BELLCRANK WELDMENT	1
27	22693	CAPSCREW, HEX HEAD (3/8 - 16 x 3/4 G5)	2
28	11073	WASHER (1/2)	1
29	69979	COLLAR	1
30	69978	PIN	1
31	21119	O-RING	1
32	69963	CONTROL CABLE ADJUSTER	1
33	27475	NYLON PELLET	1

CABLE DRUM GROUP

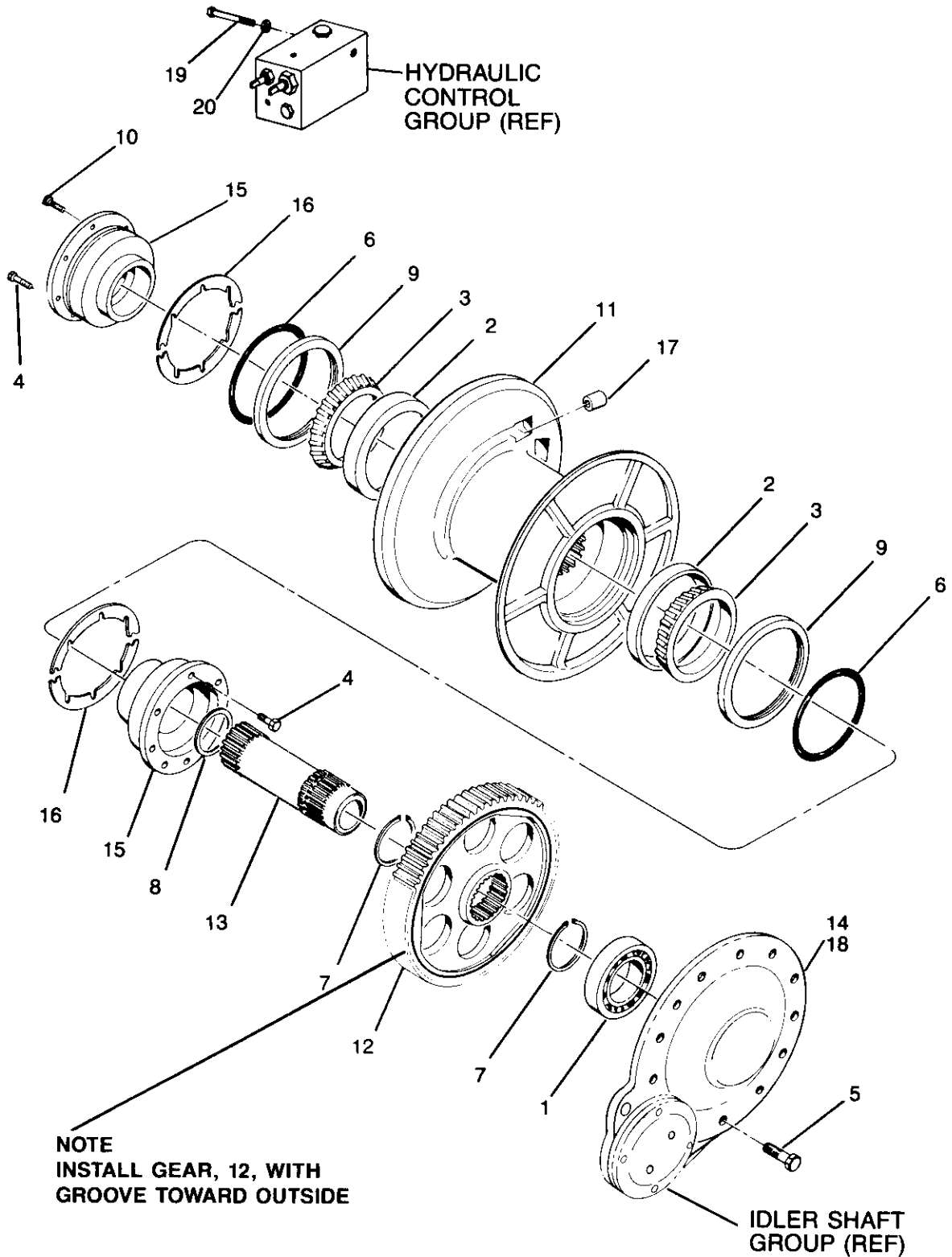

CABLE DRUM GROUP

CABLE DRUM GROUP

ITEM	PART NO.	DESCRIPTION	QTY.
1	70070	BALL BEARING	1
2	70078	BEARING CUP	2
3	70079	BEARING CONE	2
4	27745	CAPSCREW, HEX HEAD (1/2 - 13 x 1 G5 - SS)	10
5	13938	CAPSCREW, HEX HEAD (1/2 - 13 x 1/4 G5)	11
6	70140	O-RING	2
7	70513	RETAINING RING	2
8	70164	RETAINING RING	1
9	70167	OIL SEAL	2
10	27743	CAPSCREW, SOCKET HEAD (1/2 - 13 x 1 G8 - SS)	1
11	69998	CABLE DRUM	1
12	68863	GEAR, 2ND REDUCTION	1
13	69988	SHAFT, 2ND REDUCTION	1
14	28954	BEARING CARRIER, COVER	1
15	27311	BEARING CARRIER, DRUM	2
16	70264	SHIM SET (1 pair ea., .005 in., .007 in., .020 in., .13 mm, .18 mm, .5 mm)	1-2
17	29424	FERRULE — 3/4 in. (19 mm) WIRE ROPE	1
18	—	NO GASKET, USE DOW RTV 732 OR EQUIVALENT	—
19	27744	CAPSCREW, HEX HEAD (1/2 - 13 x 5 G5 - SS)	1
20	11073	WASHER (1/2)	1

SS - SELF SEALING

**HYDRAULIC CONTROL GROUP
STANDARD PTO**

SECTION AA

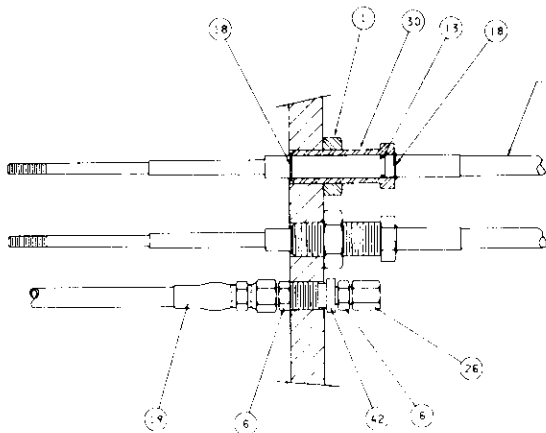
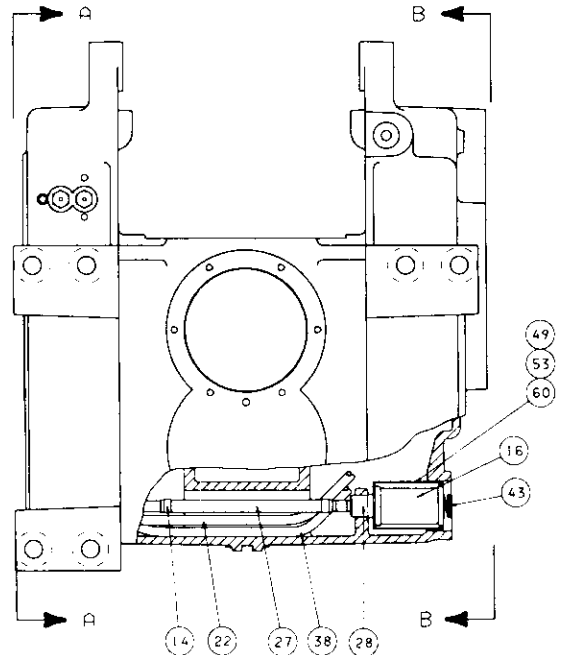
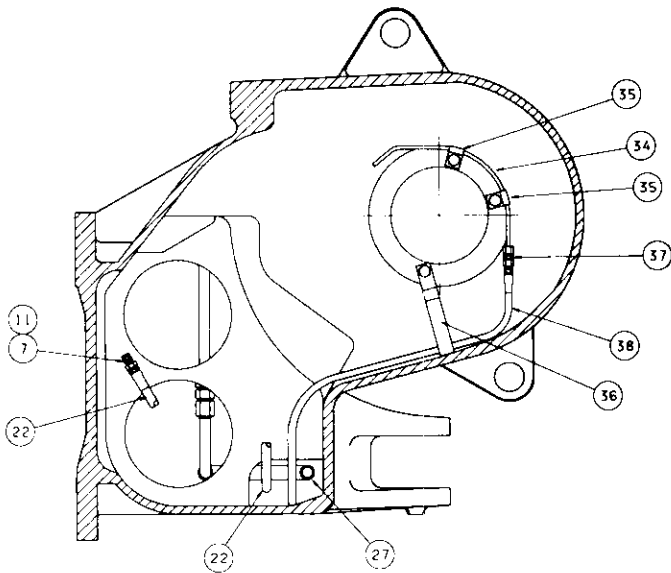
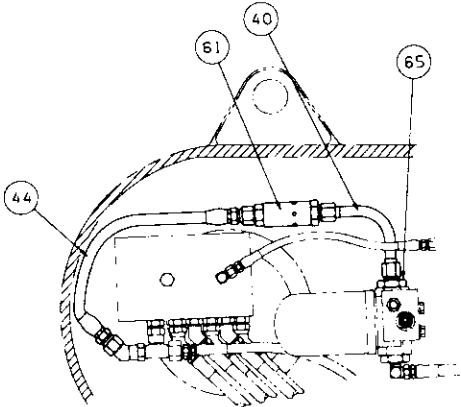
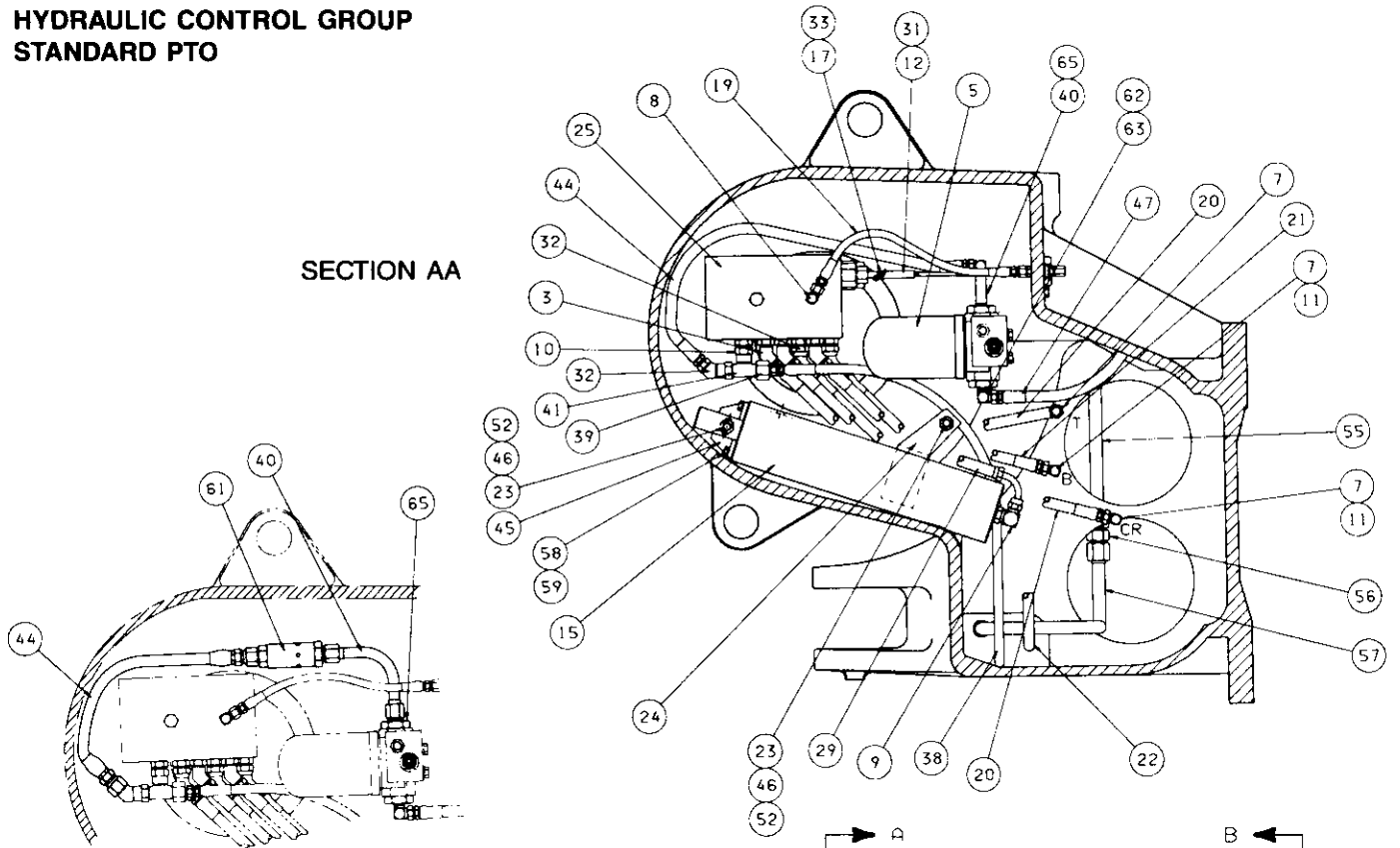

CABLE CONTROL GROUP

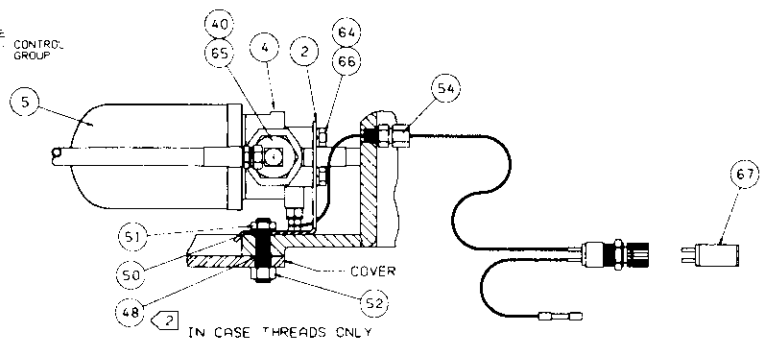

**HYDRAULIC CONTROL GROUP
STANDARD PTO**

ITEM	PART NO.	DESCRIPTION	QTY.
1	11059	JAM NUT	2
2	27741	FILTER BRACKET	1
3	69605	ELBOW - 45° - 8 VALVE PORTS A, B	2
4	27390	FILTER HEAD	1
5	27389	FILTER ELEMENT	1
6	21219	ADAPTER 1/8 - NPT - 4	2
7	70106	ADAPTER - 8	4
8	25131	ELBOW - 90° - 4 VALVE PORT G	1
9	70109	ELBOW - 90° - 8	1
10	70100	ADAPTER VALVE PORTS P, T, C1, C2	4
11	29046	ADAPTER - 90° - 8	3
12	69771	CLEVIS YOKE	2
13	21119	O-RING	2
14	30997	CLAMP, SUCTION HOSE	1
15	81959	ACCUMULATOR ASSEMBLY - SPRING TYPE (REF. PG. 24)	1
16	70189	SUCTION STRAINER	1
17	69313	CLEVIS PIN	2
18	69653	RETAINING RING	4
19	25750	HOSE - VALVE TO GAUGE PORT	1
20	70272	HOSE - 24 in. (610 mm) VALVE TO T, CR	2
21	69526	HOSE - 18 in. (457 mm) VALVE TO B	1
22	27989	HOSE - 50 in. (1,270 mm) VALVE TO CL	1
23	11026	LOCKWASHER - 1/2	2
24	27848	ACCUMULATOR CLAMP BRACKET	1
25	27689	CONTROL VALVE ASSEMBLY (REF. PG. 25)	1
26	70182	CAP - 4	1
27	27981	SUCTION HOSE ASSEMBLY	1
28	69051	CONNECTOR	1
29	27982	HOSE - 16 in. (406 mm) VALVE TO ACCUMULATOR	1
30	69963	ADJUSTER, CONTROL CABLE	2
31	13468	JAM NUT - 1/4 - 28	2
32	69516	ADAPTER - 45° - 8 VALVE PORTS P, T, C1, C2	3
33	69312	HITCH PIN	2
34	68996	LUBE TUBE	1
35	68994	CLAMP, LUBE TUBE	2

ITEM	PART NO.	DESCRIPTION	QTY.
36	68995	CLAMP, LUBE TUBE	1
37	25891	UNION - 4	1
38	25893	HOSE, LUBRICATION	1
39	27396	REDUCER - 8 - 4 VALVE PORT P	1
40	27392	ELBOW 90° XLG 1/2 NPT - 8	1
	29335	TUBE ASSEMBLY - FLOW CONTROL*	1
41	69330	TEE, SWIVEL - 8 VALVE PORT P	1
42	27386	SLEEVE	1
43	26005	SPRING	1
44	27983	HOSE - 26 in. (660 mm) FLTR TO VALVE W/O FLO CTL	1
	27979	HOSE - 17 in. (432 mm) FLOW CONTROL TO VALVE*	1
45	27847	ACCUMULATOR MOUNTING ANGLE	1
46	27849	STUD (1/2 - 13 x 2 3/4)	2
47	27979	HOSE - 17 in. (432 mm) PUMP TO FILTER	1
48	27081	STUD (1/2 - 13 NC x 2 1/4)	1
49	29020	SUCTION STRAINER SHIELD	1
50	12781	LOCKWASHER, SHAKEPROOF - 1/2	1
51	23583	JAM NUT (1/2 - 13)	1
52	11788	HEX NUT (1/2 - 13)	5
53	29021	SEAL RING .25 in. (6.4 mm) THICK	1
54	61914	WIRING ASSEMBLY - INCLUDES ITEM 67	1
55	27977	UPPER SUCTION TUBE	1
56	27990	UNION, TUBING	1
57	27978	LOWER SUCTION TUBE	1
58	11766	CAPSCREW, HEX HEAD (5/16 - 18 x 7/8 G5)	2
59	11024	LOCKWASHER - 5/16	2
60	29023	SEAL RING .06 in. (1.5 mm) THICK	1-2
61	29334	FLOW CONTROL VALVE*	1
62	31347	ELBOW 90° 1/2 NPT - 8	1
63	27397	ADAPTER - 1/2 NPT	1
64	18003	LOCKWASHER 3/8	2
65	27397	ADAPTER - 1/2 NPT USED W/O FLO CTL	1
	29352	ADAPTER - 8 USED WITH FLO CTL*	1
66	22693	CAPSCREW, HEX HEAD 3/8 - 16 x 3/4 G5	2
67	27091	INDICATOR LAMP	1

*FLOW CONTROL VALVE USED IN S/N 9200557 AND LATER

HYDRAULIC COMPONENTS

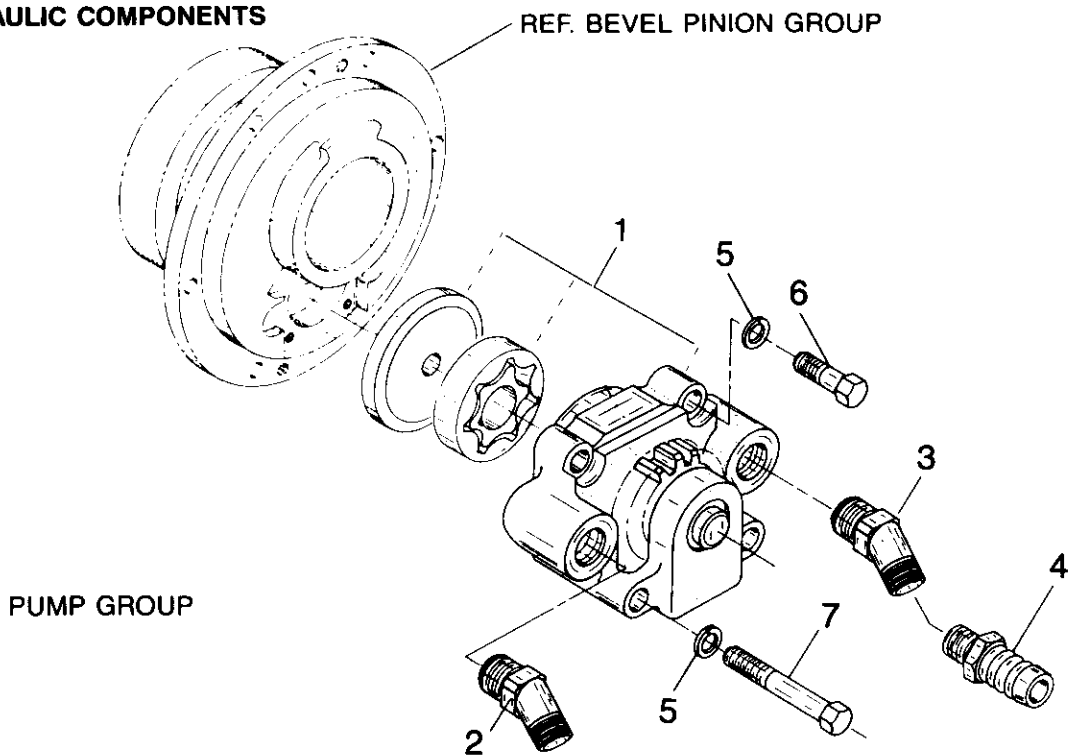

ITEM	PART NO.	DESCRIPTION	QTY
1	68772	PUMP ASSEMBLY	1
2	26752	ELBOW, 45° — 8 PRESSURE SIDE*	1
3	27991	ELBOW, 45° SUCTION — STD PTO	1
	69047	ELBOW, 45° 1/2 NPT ADAPTER — LOW PTO	1
4	69048	BARBED HOSE ADAPTER — LOW PTO	1
5	11015	LOCKWASHER — 1/4	4
6	27996	CAPSCREW, HEX HEAD 1/4 - 20 x 1 1/2 G8)	2
7	27997	CAPSCREW, HEX HEAD 1/4 - 20 x 3 G8	2

*ITEMS 2, 3 & 4 SHOWN FOR COUNTERCLOCKWISE (CCW) BEVEL PINION ROTATION. REVERSE PORT LOCATION FOR CLOCKWISE (CW) BEVEL PINION ROTATION.

ACCUMULATOR ASSEMBLY

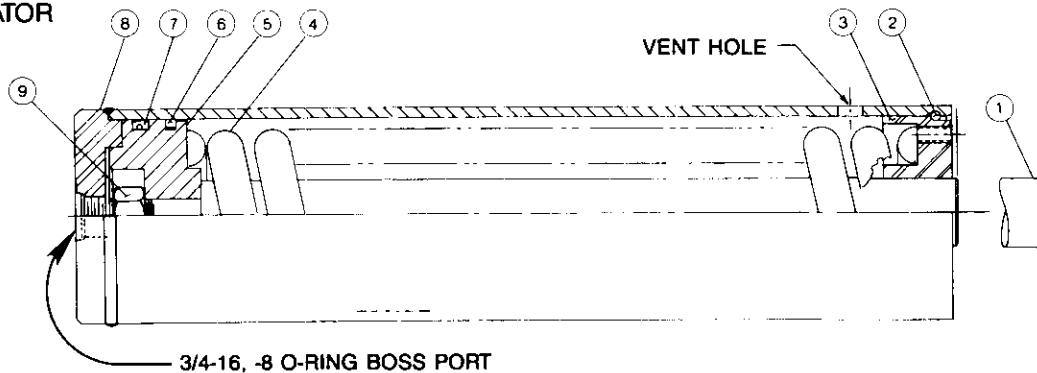

ITEM	PART NO.	DESCRIPTION	QTY
1	NSS	ROD	1
2	27836	RETAINING RING	1
3	NSS	ROD GUIDE	1
4	NSS	SPRING	1
5	NSS	PISTON	1
6	27833	CAST IRON PISTON RING	1
7	27832	SEAL ASSEMBLY	1
8	NSS	TUBE ASSEMBLY	1
9	NSS	NUT	1
—	62131	SEAL KIT (CONTAINS ITEMS 2, 6 & 7)	

⚠ DANGER

2,000 LB. (900 Kg) SPRING PRELOAD — USE PRESS FOR DISASSEMBLY PER SERVICE INSTRUCTIONS IN SERVICE BULLETIN 95. PROPERTY DAMAGE, SEVERE PERSONAL INJURY OR DEATH MAY RESULT IF ROD GUIDE REMOVAL IS ATTEMPTED WITHOUT A PRESS.

CONTROL VALVE ASSEMBLY
27689

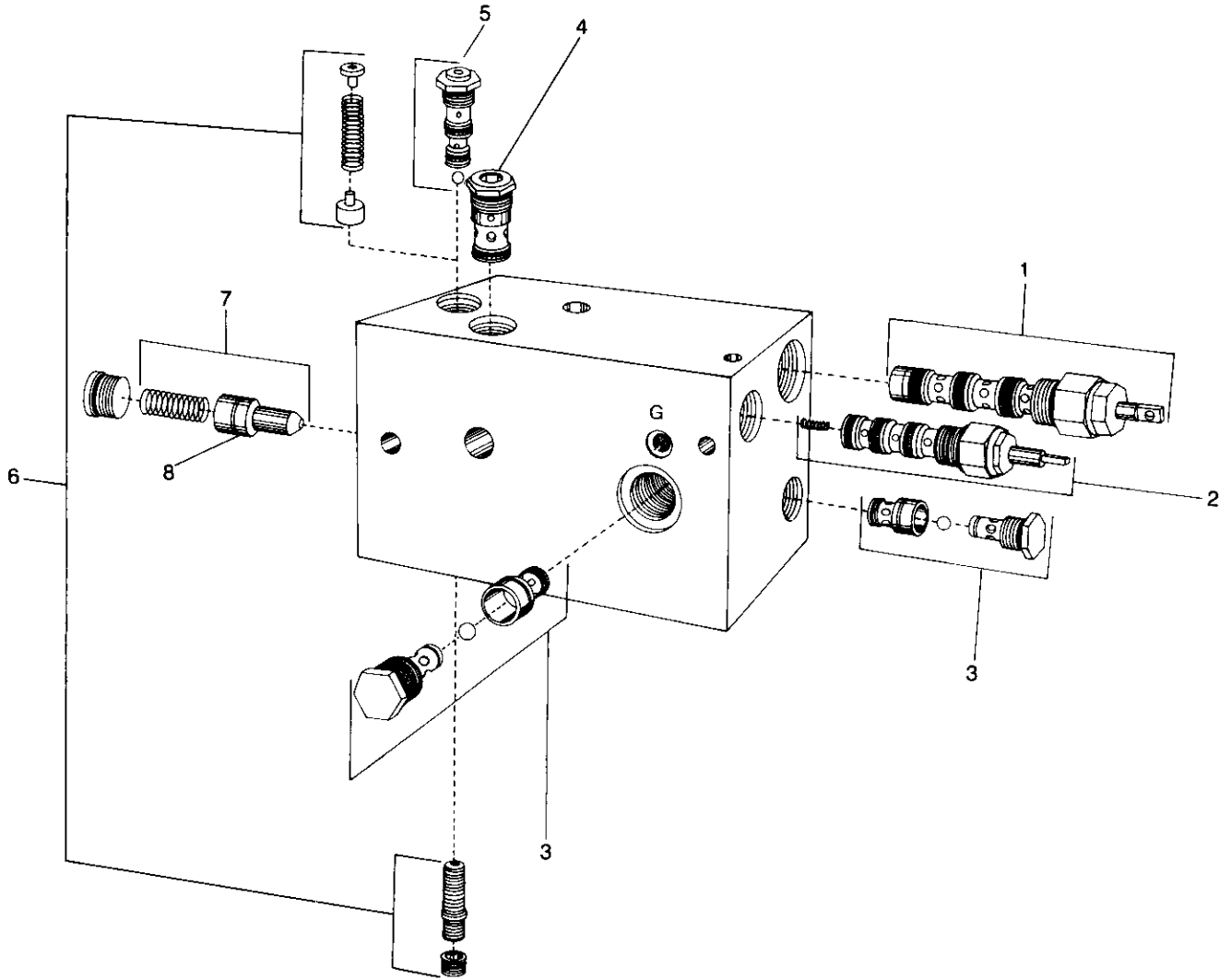

ITEM	PART NO.	DESCRIPTION	QTY.
1	26712	DIRECTIONAL CONTROL CARTRIDGE	1
	61838	SEAL KIT FOR ITEM 1	1
2	26713	BRAKE CONTROL CARTRIDGE	1
	61839	SEAL KIT FOR ITEM 2	1
3	26715	SHUTTLE VALVE ASSEMBLY	2
	61841	SEAL KIT FOR ITEM 3	2
4	27672	CHECK VALVE CARTRIDGE	1
	61840	SEAL KIT FOR ITEM 4	1
5	26716	DIFFERENTIAL UNLOADING PILOT VALVE CARTRIDGE	1
	61842	SEAL KIT FOR ITEM 5	1
6	62063	DIF. UNLOADING VALVE REPAIR KIT, INCLUDES ITEM 5	5
7	62062	UNLOADING POPPET ASSEMBLY	1
8	22454	O-RING	1

CONTROL STAND

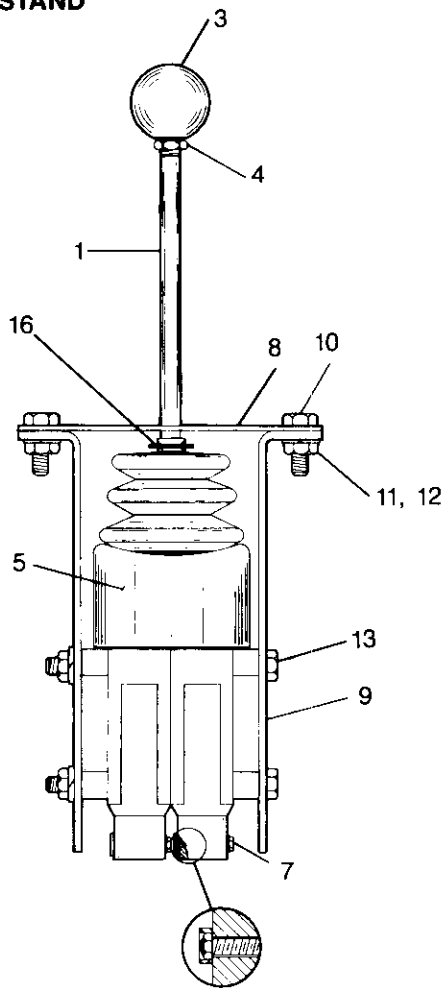

**CONTROL STAND KIT
81965 WITHOUT FREESPOOL**

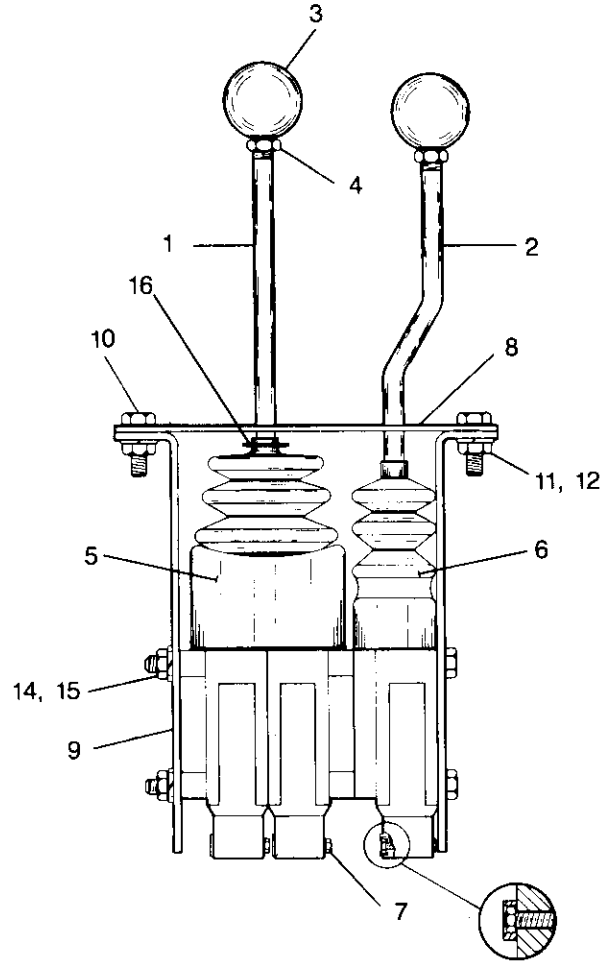

**CONTROL STAND KIT
69667 WITH FREESPOOL**

ITEM	PART NO.	DESCRIPTION	QTY.
	81965	CONTROL STAND KIT WITHOUT FREESPOOL	
	69667	CONTROL STAND KIT WITH FREESPOOL	
1	27393	CONTROL ASSEMBLY — POWER SHIFT (CONTAINS CONTROL PLUS ITEMS 3, 4, 5 & 7)	1
2	69444	CONTROL ASSEMBLY — FREESPOOL (CONTAINS CONTROL PLUS ITEMS 3, 4, 6 & 7)	1
3	26696	KNOB	1-2
4	12793	JAM NUT	1-2
5	26697	BOOT — FOR ITEM 1	1
6	26698	BOOT — FOR ITEM 2	1
7	—	CAPSCREW — CABLE LOCK 10-32 UNF × 1 3/16" LG	2-3
8	69893	GATE PLATE, WITH F.S.	1
	27865	GATE PLATE, WITHOUT F.S.	1
9	69891	CONTROL STAND BRACKET	2
10	69643	CAPSCREW, HEX HEAD — 1/4 - 20 × 3/4 G5	4
11	23195	LOCKWASHER — 1/4	4
12	69645	NUT, HEX — 1/4 - 20	4
13	69642	CAPSCREW, HEX HEAD — 5/16 - 18 × 5 1/2 G5	3
	27878	CAPSCREW, HEX HEAD — 5/16 - 18 × 4 G5	3
14	69640	LOCKWASHER — 5/16	3
15	69644	NUT, HEX — 5/16 - 18	3
16	32489	TIE STRAP	1

FAIRLEAD ASSEMBLY

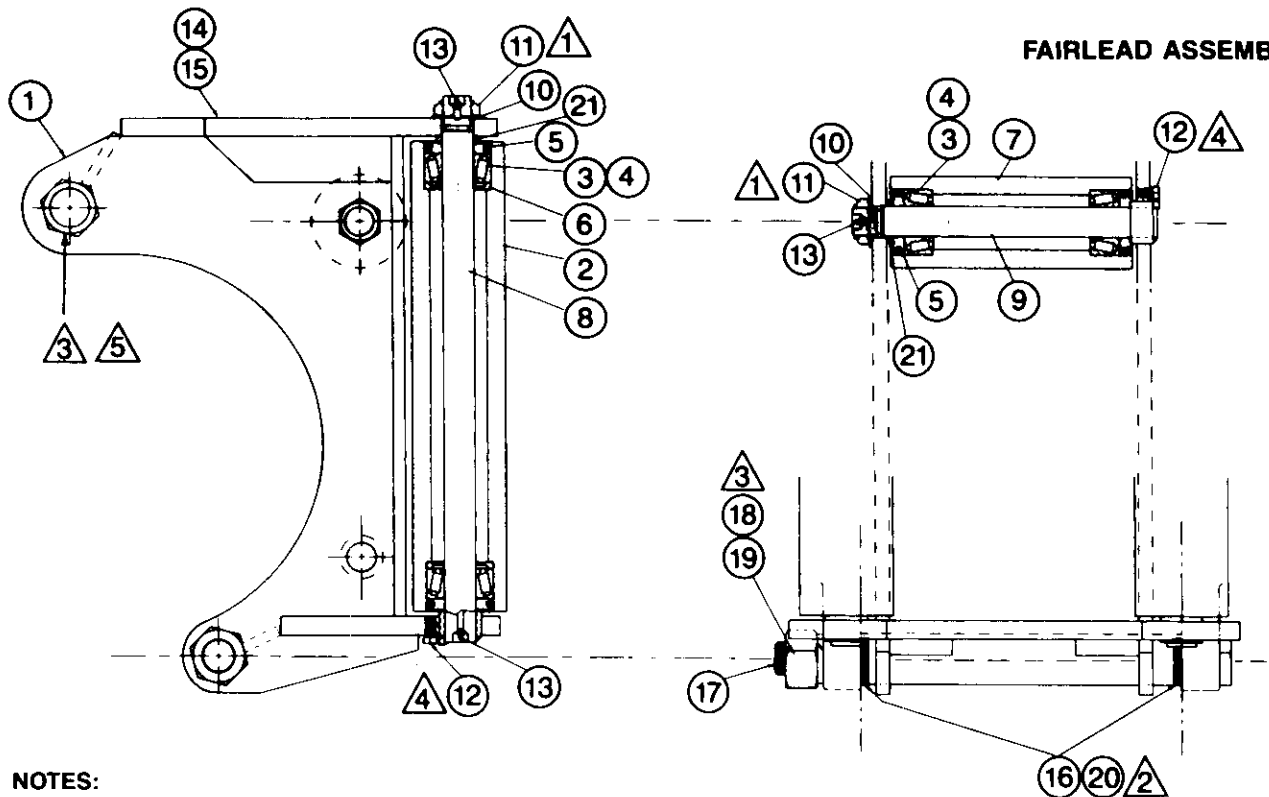

NOTES:

- 1 WHILE TURNING ROLLER, TIGHTEN NUT. WHEN ROLLER WILL TURN NO LONGER, BACK NUT OFF $\frac{1}{8}$ TURN.
- 2 SHIM BOTH SIDES AS REQUIRED TO REDUCE END PLAY TO LESS THAN .030 in. (.8 mm).
- 3 TIGHTEN UNTIL WASHER IS FLATTENED. THEN TURN 1 FLAT.
- 4 APPLY "LOCTITE 242" AND INSTALL WITH FLAT TANGENT TO HOLE PRIOR TO INSTALLATION OF SHAFT.
- 5 WHEN INSTALLING FAIRLEAD ON WINCH IN FIELD, REMOVE ORIGINAL CABLE GUARD SPACER TUBE AND REUSE UPPER TIE BOLT 28772, LOCKWASHER 27666 AND NUT 27655.

ITEM	PART NO.	DESCRIPTION	QUANTITY	
			3 ROLLER	4 ROLLER
	81970	3 ROLLER FAIRLEAD ASSEMBLY		
	81971	4 ROLLER FAIRLEAD ASSEMBLY		
1	27817	FAIRLEAD FRAME	1	1
2	36788	ROLLER — VERTICAL	2	2
3	70833	BEARING CONE	6	8
4	70834	BEARING CUP	6	8
5	70864	DUST GUARD ASSEMBLY	6	8
6	70865	GREASE RETAINER	4	4
7	27886	ROLLER — HORIZONTAL	1	2
8	36797	SHAFT — VERTICAL	2	2
9	27901	SHAFT — HORIZONTAL	1	2
10	70850	WASHER	3	4
11	70863	LOCK NUT	3	4
12	22729	CAPSCREW, HEXHEAD ($\frac{1}{2}$ NC \times $\frac{3}{4}$ GD5)	3	4
13	18047	GREASE FITTING	5	6
14	69534	NAMEPLATE	1	1
15	70053	DRIVE SCREW	4	4
16	24912	SHIM .030 in. (.8 mm)	4-AR	4-AR
17	28772	TIE BOLT	1	1
18	27666	LOCK WASHER	1	1
19	27655	NUT, HEX HEAD	1	1
20	25590	SHIM .125 in. (3.18 mm)	6-AR	6-AR
21	70880	SPACER	3	4

AR - AS REQUIRED

**CONTROL CABLE
GUARD GROUP**

Material: Plate .25 in. (6 mm) thick, hot rolled, descaled,
ASTM A36 or AISI 1015.

Bend Radii: .25 in. (6 mm) minimum, corner notches
at bend lines to be 60°-90°.

Cable Guard, LH

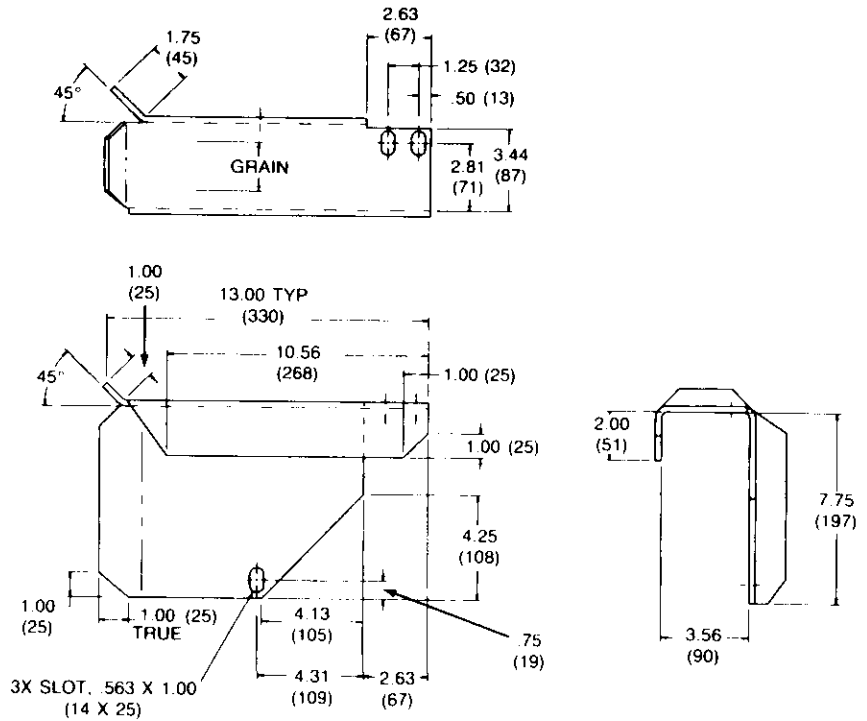
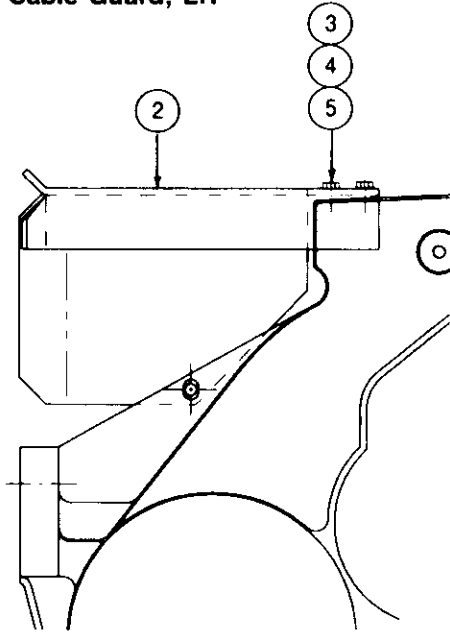

Cable Guard, RH

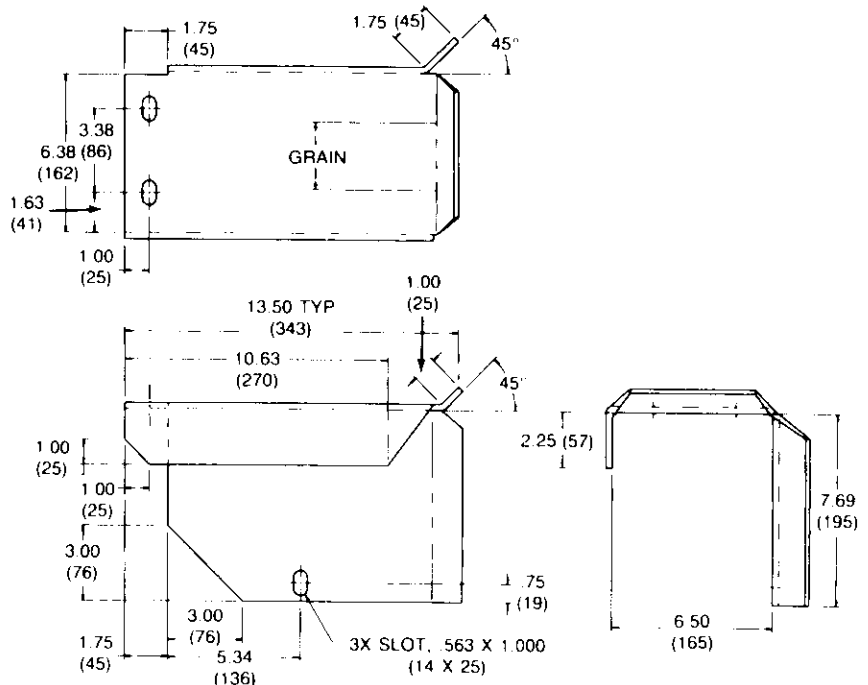
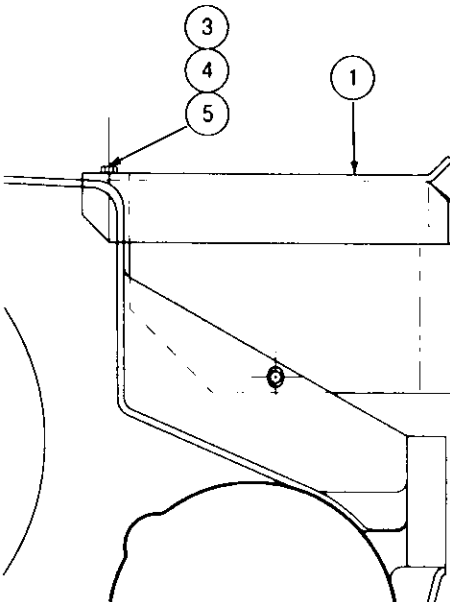

ITEM	PART NO.	DESCRIPTION	QTY.
1	100173	CABLE GUARD, RH	1
2	100174	CABLE GUARD, LH	1
3	22697	CAPSCREW, HEX HEAD, 1/2 - 13 x 1 Gd5	6
4	11026	LOCKWASHER, 1/2	6
5	11073	WASHER, 1/2	6

Cable Guard Kit 62564 contains items 1-5 above.