

PARTS LIST SECTION

**CARCO MODEL 60-PS, PSM AND PSC WINCH
WITH INTERNAL HYDRAULICS**

FOR
JI CASE 1450B P.S. TRACTOR

BEVEL GEAR SHAFT	18-19
BEVEL PINION AND DRIVE GEAR ASSY. (PS AND PSM)	8
BRAKE CONTROL (PS, SPRING APPLIED)	28
BRAKE CONTROL (PSM AND PSC, MANUAL)	27
BRAKE CYLINDER	29
BRAKE SHAFT, BRAKE BAND AND LINING	21
CLUTCH	20
CONTROL GROUP (CONTROL STANDS, CONTROL CABLES, PRESSURE GAUGES)	4, 5, 6, 7
CONTROL STAND COMPONENTS (POWER SHIFT)	30
CONTROL STAND COMPONENTS (PSM AND PSC, MANUAL)	32
CONTROL STAND COMPONENTS (FREE SPOOL)	31
CONTROL VALVE	12, 13
DRUM SHAFT STANDARD (NO FREE SPOOL)	23
DRUM SHAFT (WITH FREE SPOOL)	26
FAIRLEAD	34-35
HYDRAULIC TUBING AND FITTINGS	14-15
IDLER SHAFT (NO FREE SPOOL)	22
IDLER SHAFT (WITH FREE SPOOL)	24-25
INTEGRAL ARCH ASSEMBLY	36
MOUNTING GROUP 1450B WITHOUT ARCH (PTO SHAFT, STUDS, CAP SCREWS)	2
MOUNTING GROUP 1450B WITH ARCH (PTO SHAFT, STUDS, CAP SCREWS)	3
MOUNTING GROUP 1450 WITH OR WITHOUT ARCH (PTO SHAFT, STUDS, CAP SCREWS)	3
PUMP GROUP (PUMP, TUBING, FILTER)	16-17
PRESSURE GAUGE KIT COMPONENTS	33
WINCH CASE	10-11

Note: Purchased parts, such as bearings and oil seals may be substituted with parts of equal quality on the manufacturer's recommendation, and with the approval of Pacific Car and Foundry Company.

ATTENTION: Be sure to give correct part number, part name and complete serial number of winch when ordering. Also name and model of the tractor on which the winch is mounted.

CARCO WINCH PRODUCTS

A DIVISION OF PACIFIC CAR / 1400 NORTH 4TH STREET, RENTON, WA 98055 U.S.A. (206) 251-7834/TELEX: 32-8942

2580-F-10-30-83
SUPERSEDES
2580-F-3-30-80

CARCO MODEL 60-PS, PSM & PSC WINCH
 MOUNTING GROUP PARTS LIST—PAGE 2
 JI CASE 1450B P.S. TRACTOR

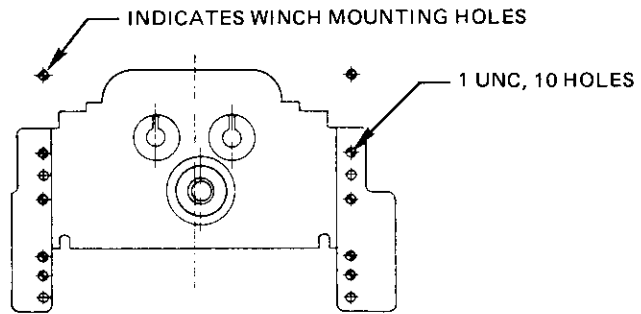

VIEW OF TRACTOR, REAR FACE

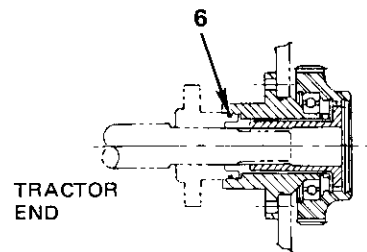
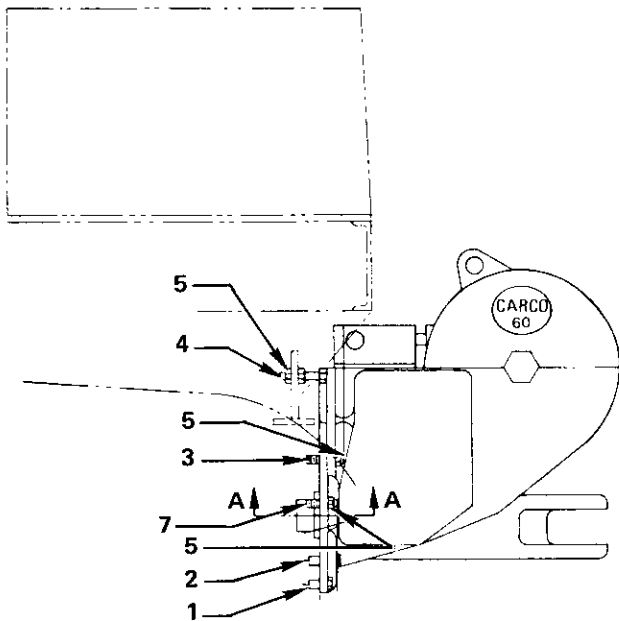

SECTION A-A

MOUNTING GROUP WITHOUT ARCH NO. 53467

REF.	CARCO PART NO.	NAME AND DESCRIPTION	QUAN. PER UNIT
1	16047-1618	Cap Screw (1 UNC x 2-1/4)	2
2	16047-1624	Cap Screw (1 UNC x 3)	2
3	45050-1633	Stud	2
4	49415	Stud	2
5	16400-16	Nut (1 UNC)	10
6	16262-230	O-Ring (NAT'L. 623008)	1
7	45050-1628	Stud	2

CARCO MODEL 60-PS, PSM & PSC WINCH WITH ARCH
ARCH MOUNTING GROUP PARTS LIST—PAGE 3
 JI CASE 1450B P.S. TRACTOR

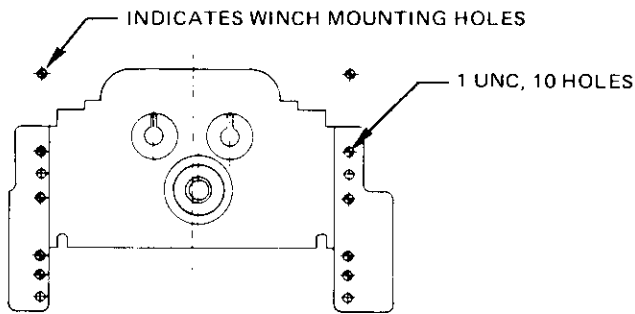

VIEW OF TRACTOR, REAR FACE

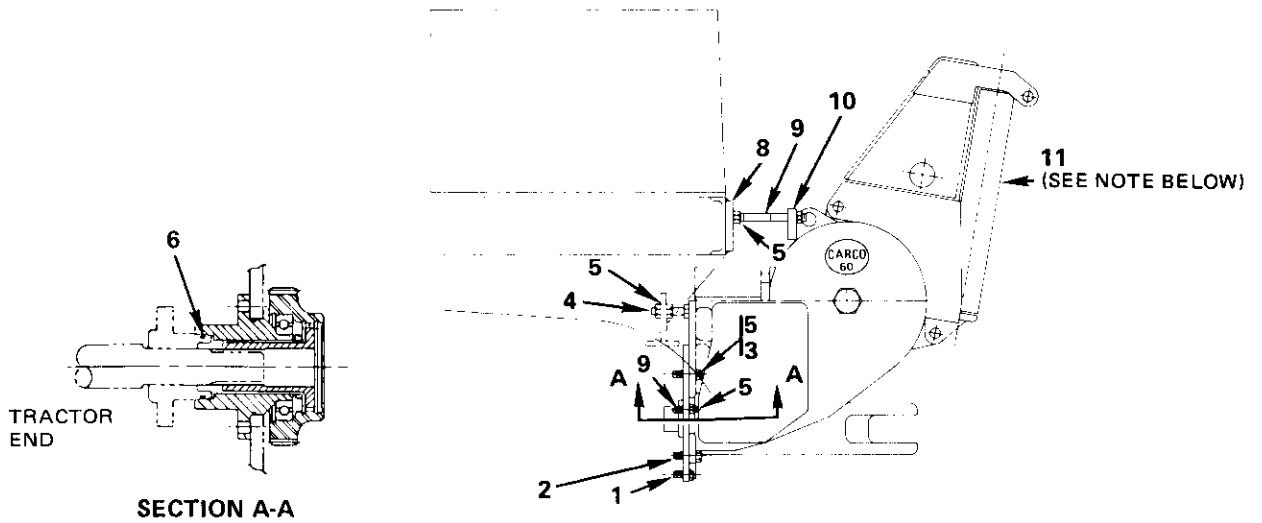

MOUNTING GROUP WITH ARCH NO. 53431

REF.	CARCO PART NO.	NAME AND DESCRIPTION	QUAN. PER UNIT
1	16047-1618	Cap Screw (1 UNC x 2-1/4)	2
2	16047-1624	Cap Screw (1 UNC x 3)	2
3	45050-1633	Stud	4
4	49415	Stud	2
5	16400-16	Nut (1 UNC)	14
6	16262-230	O-Ring (NAT'L. 623008)	1
7	45050-1628	Stud	2
8	53436	Plate	2
9	51495-1654	Stud	2
10	53437	Plate	2
11	53299	Integral Arch Assembly (See Page 36)	1

NOTE: This mounting group must be used when an integral arch is mounted on winch.

CARCO MODEL 60-PS WINCH
 CONTROL GROUP PARTS LIST—PAGE 4
 JI CASE 1450B P.S. TRACTOR

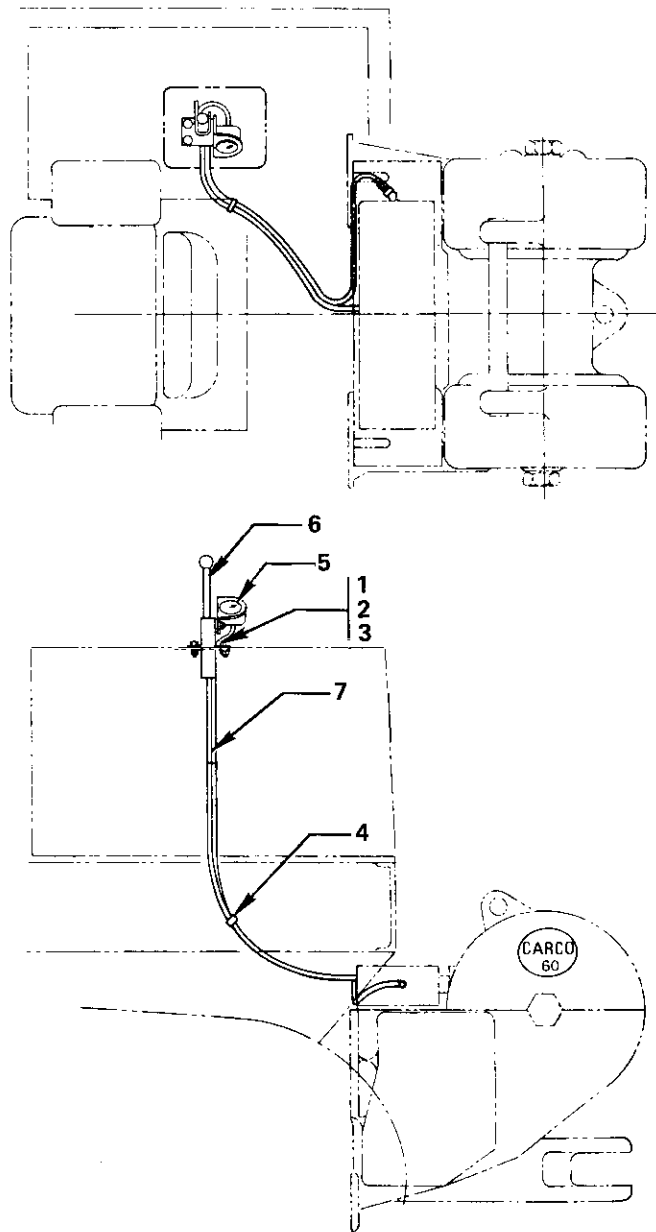

CONTROL GROUP (PS WITHOUT FREE SPOOL) NO. 52324

REF.	CARCO PART NO.	NAME AND DESCRIPTION	QUAN. PER UNIT
1	16033-6	Nut (3/8 UNC)	4
2	16047-610	Cap Screw (3/8 UNC x 1-1/4)	4
3	16067-6	Lock Washer (3/8)	4
4	16459-2	Strap, Retaining	1
5	48700-120	Pressure Gauge Kit (See Page 33)	1
6	49001-3	Control Stand, Power Shift (See Page 30)	1
7	52000-078	Cable, Power Shift Control	1

CARCO MODEL 60-PS WINCH
 CONTROL GROUP PARTS LIST—PAGE 5
 JI CASE 1450B P.S. TRACTOR

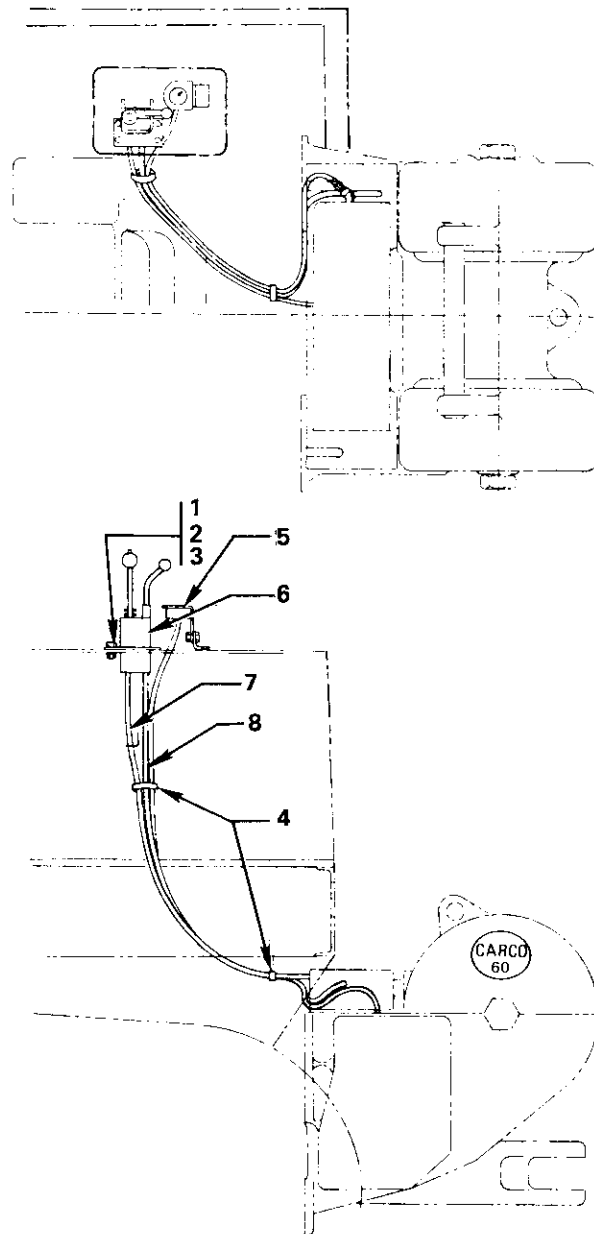

CONTROL GROUP (PS WITH FREE SPOOL) NO. 52325

REF.	CARCO PART NO.	NAME AND DESCRIPTION	QUAN. PER UNIT
1	16033-6	Nut (3/8 UNC)	4
2	16047-610	Cap Screw (3/8 UNC x 1-1/4)	4
3	16067-6	Lock Washer (3/8)	4
4	16459-2	Strap, Retaining	2
5	48944-120	Pressure Gauge Kit (See Page 33)	1
6	49805-8	Control Stand, Power Shift & Free Spool (See Page 31)	1
7	52000-078	Cable, Power Shift Control	1
8	52400-084	Cable, Free Spool Control	1

CARCO MODEL 60-PSM & PSC WINCH
 CONTROL GROUP PARTS LIST—PAGE 6
 JI CASE 1450B P.S. TRACTOR

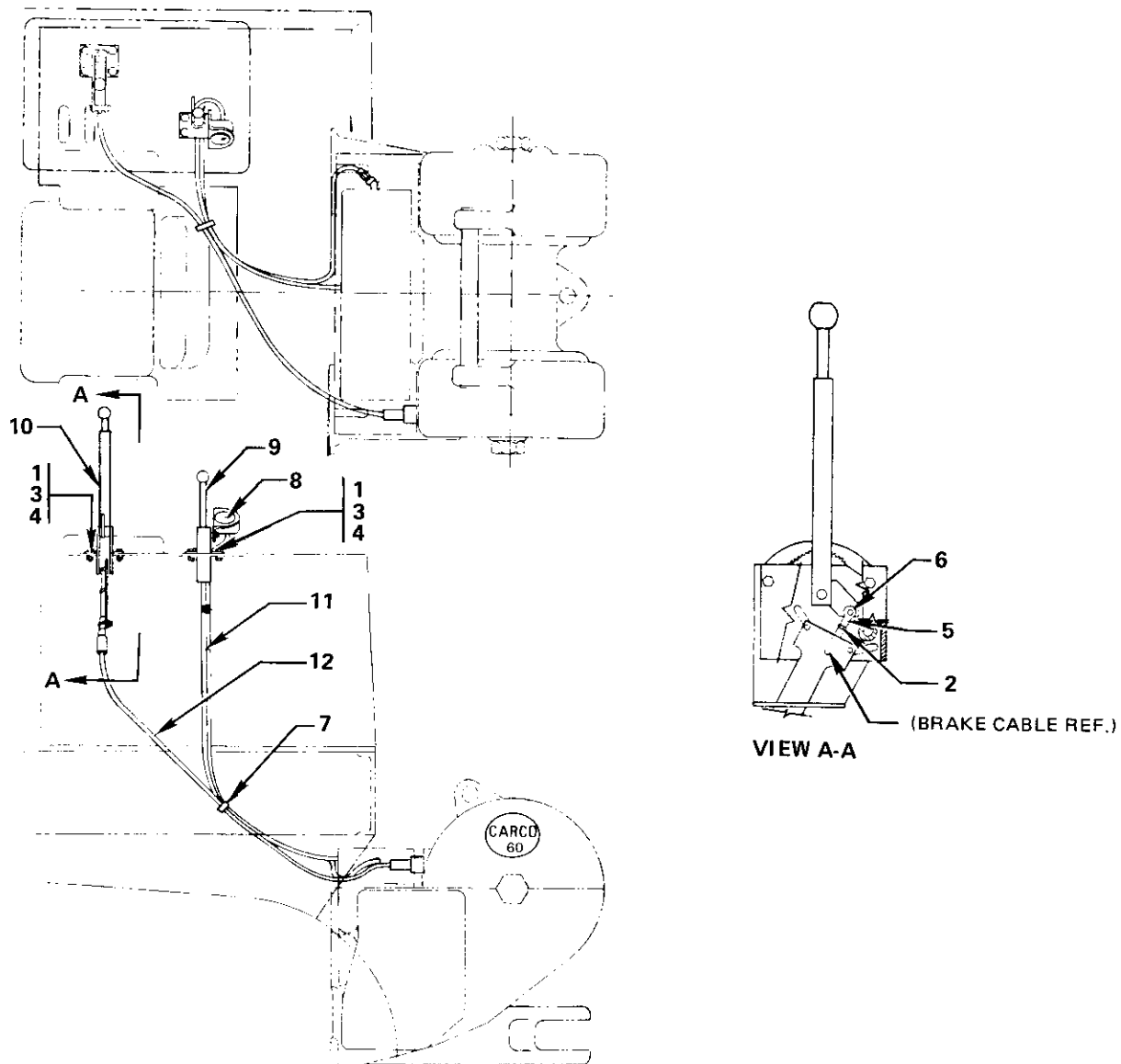

CONTROL GROUP (PSM & PSC WITHOUT FREE SPOOL) NO. 52326

REF.	CARCO PART NO.	NAME AND DESCRIPTION	QUAN. PER UNIT
1	16033-6	Nut (3/8 UNC)	8
2	16044-6	Jam Nut (3/8 UNF)	1
3	16047-610	Cap Screw (3/8 UNC x 1-1/4)	8
4	16067-6	Lock Washer (3/8)	8
5	16245-6	Yoke	1
6	16246-6	Pin Assembly	1
7	16459-2	Strap, Retaining	1
8	48700-120	Pressure Gauge Kit (See Page 33)	1
9	53598-03	Control Stand, Power Shift (See Page 30)	1
10	49434-7	Control Stand, Brake (See Page 32)	1
11	52000-078	Cable, Power Shift Control	1
12	48850-84	Cable, Brake Control	1

CARCO MODEL 60-PS & PSM WINCH
 BEVEL GEAR GROUP—PAGE 8
 JI CASE 1450B P.S. TRACTOR

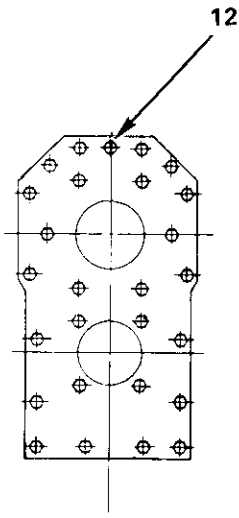

ITEM 17

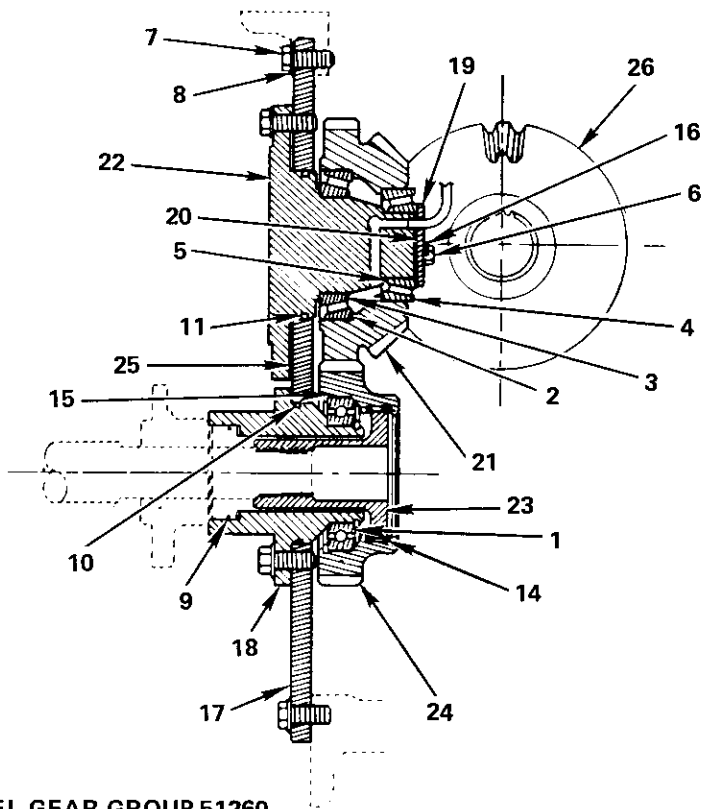

NOTE: BEVEL GEAR GROUP
 51260 EFFECTIVE WITH
 MODEL 60, S/N 6-1592 AND UP.

BEVEL GEAR GROUP 51260

REF.	CARCO PART NO.	NAME AND DESCRIPTION	QUAN. PER UNIT
1	15090	Ball Bearing	1
2	15285	Bearing Cup	1
3	15286	Bearing Cone	1
4	15287	Bearing Cup	1
5	15288	Bearing Cone	1
6	16024-3	Cap Screw (3/8 UNF x 1 Hex Dr. Hd.)	2
7	16047-810	Cap Screw (1/2 UNC x 1-1/4 H.H.)	24
8	16064-8	Washer (1/2)	24
9	16262-230	O-Ring (NAT'L.)	1
10	16262-240	O-Ring (NAT'L. 623018)	1
11	16262-242	O-Ring (NAT'L. 623020)	1
12	16290-1620	Dowel Pin (1/2 x 1-1/4)	1
13	16313-275	Retaining Ring (TRUARC 5100-275)	1
14	16314-362	Retaining Ring (TRUARC N5000-362)	2
15	16314-433	Retaining Ring (TRUARC N5000-433)	1
16	48125-3	Lock Wire (16 Ga. x 24)	1
17	49269	Cover Plate	1
18	49276	Bearing Carrier	1
19	49279	Lock Plate	1
20	49387	Shim Set	1
21	49271	Bevel Pinion	1
22	50433	Bearing Spindle	1
23	51707	Coupling	1
24	51708	Pinion	1
25	53348-1	Shim Set	1
26	49274	Bevel Gear	1

2583-B-10-30-83
 SUPERSEDES
 2583-B-3-15-79

(This Page Intentionally Left Blank)

CARCO MODEL 60-PS, PSM & PSC WINCH
 PARTS LIST SECTION—PAGE 10
 WINCH CASE AND COVERS

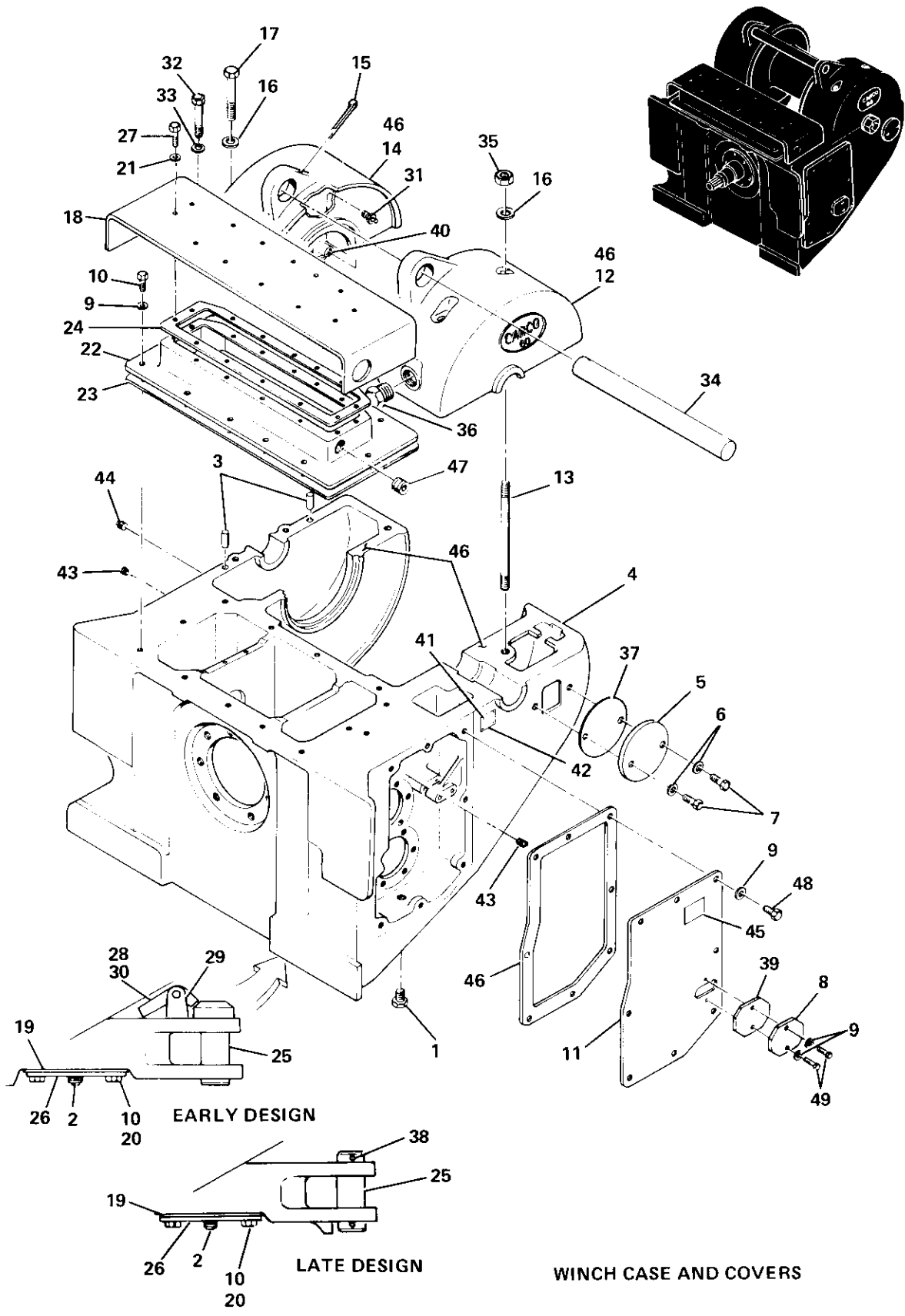

CARCO MODEL 60-PS, PSM & PSC WINCH
PARTS LIST SECTION—PAGE 11
WINCH CASE AND COVERS
JI CASE 1450B P.S. TRACTOR

REF.	CARCO PART NO.	NAME AND DESCRIPTION	QUAN. PER UNIT
1	16169-8	Plug (1/2 NPT Sq. Hd.)	1
2	16168-16	Plug (1 NPTF Mag. Sq. Hd.)	1
3	16290-1616	Pin, Dowel (1/2 x 1)	2
4	NSS	Case Complete (Includes Items 12 and 14)	1
5	42048	Cover	1
6	16064-10	Washer (5/8)	2
7	16047-1008	Cap Screw (5/8 UNC x 1 H.H.)	2
8	44816	Cover	1
9	16064-8	Washer (1/2)	22
10	16047-810	Cap Screw (1/2 UNC x 1-1/4 H.H.)	30
11	45972	Cover	1
12	NSS	Cover, Brake Case	1
13	45050-1655	Stud (1x11-1/2 UNC)	2
14	NSS	Cover, Gear Case	1
15	16288-1272	Pin, Cotter (3/8 x 4-1/2)	1
16	16064-16	Washer (1)	4
17	16047-1628	Cap Screw (1 UNC x 3-1/2 H.H.)	2
18	52321	Cover	1
19	51890	Gasket, Filter Cover	1
20	16067-8	Washer, Lock (1/2)	16
21	16064-6	Washer (3/8)	14
22	Reference Only	Housing (See Page 12)	1
23	51144	Gasket	1
24	51535	Gasket	1
25	52037	Pin, Drawbar – Early Design	1
26	53101-0002	Pin, Drawbar – Late Design	1
27	51889	Cover, Suction Filter	1
28	16047-608	Cap Screw (3/8 UNC x 1 H.H.)	14
29	16246-8	Pin, Yoke (CLEVELAND 2708½-6A)	1
30	52084	Bracket, Support	1
31	52085	Latch	1
32	16249-1	Vent, Plug (ALEMITE 317400)	1
33	16047-1220	Cap Screw (3/8 UNC x 2-1/2 H.H.)	4
34	16064-12	Washer (3/8)	4
35	49043-1	Guard, Cable	1
36	16033-16	Nut (1 UNC Hex)	2
37	16220-38	Plug (WHITE 1604-136-Y)	1
38	44833	Gasket	1
39	16288-1248	Pin, Cotter (3/8 x 3)	2
40	44815	Gasket	1
41	16150-2	Elbow (1/8 NPT 90° Street)	1
42	16055-5	Screw, Drive (#10 x 3/8 Type U)	4
43	52126	Plate, Name	1
44	16167-6	Plug (3/8 NPT Hex Soc.)	2
45	16169-20	Plug (1-1/4 NPT Sq. Hd.)	1
46	49044	Plate, Instruction	1
47	16453-5	Sealant (SILASTIC No. 732 RTV), 5 oz	1
48	52987	Plug	1
49	16047-808	Screw, Hex Hd. Cap (1/2 x 1 UNC)	8
	16047-812	Screw, Hex Hd. Cap (1/2 x 1-1/2 UNC)	2

CARCO MODEL 60-PS, PSM & PSC
PARTS LIST SECTION—PAGE 12
CONTROL VALVE
JI CASE 1450B P.S. TRACTOR

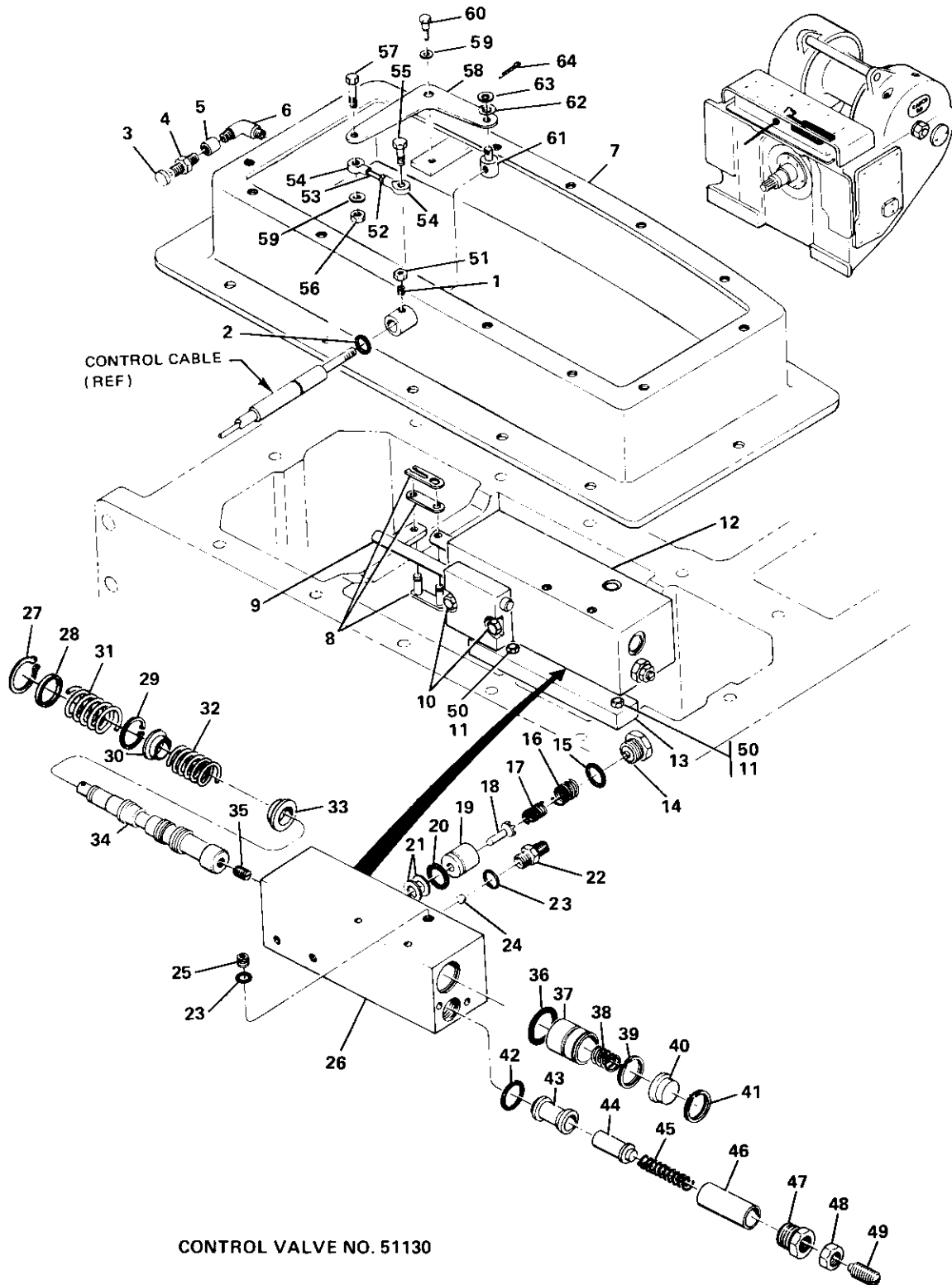

CONTROL VALVE NO. 51130

CARCO MODEL 60-PS, PSM & PSC
PARTS LIST SECTION—PAGE 13
CONTROL VALVE
JI CASE 1450B P.S. TRACTOR

REF.	CARCO PART NO.	NAME AND DESCRIPTION	QUAN. PER UNIT
1	16056-612	Set Screw (3/8 UNC x 3/4)	1
2	16262-208	O-Ring (PARKER 2-208)	1
3	16445-4	Cap Nut (AEROQUIP 21029-4)	1
4	16129-44	Connector (WTHR'D. C5205 x 4 x 4)	1
5	16362-44	Snubber (CHEMIQUIP 25B-D)	1
6	16171-44	Elbow (WTHR'D. 3400 x 4)	1
7	51948	Valve Housing	1
8	16364-2040	Connecting Link (ANSI 2040)	1
9	51946	Cable Guide	1
10	16047-610	Cap Screw (3/8 UNC x 1-1/4)	2
11	16047-612	Cap Screw (3/8 UNC x 1-1/2)	2
12	51130	Control Valve	1
13	51698-1	Support Assembly	1
14	51883-1	Retainer Assembly	1
15	16262-912	O-Ring (NAT'L. 600501)	1
16	51894	Spring	1
17	52392	Spring	1
18	51164	Piston, Accumulator Check	1
19	51886	Seat, Accumulator Check	1
20	16262-116	O-Ring (NAT'L. 622714)	1
21	51881-10	Shim Set	1
22	52289	Connector	1
23	16262-908	O-Ring (NAT'L. 600503)	2
24	16471-8	Ball Check (Nylon Type 10)	1
25	16496-8	Plug (PARKER 8HP50N-S)	1
26	NSS	Valve Body (Order 51130 Control Valve, Item 12)	1
27	16314-150	Retaining Ring (TRUARC N5000-150)	1
28	45622	Washer	1
29	16313-75	Retaining Ring (TRUARC 5100-75)	1
30	45623	Spring Stop	1
31	45549	Outer Spring	1
32	45548	Inner Spring	1
33	44259-1	Spring Stop	1
34	NSS	Valve Spool (Order 51130 Control Valve, Item 12)	1
35	16057-608	Set Screw (3/8 UNF x 1/2)	1
36	16262-215	O-Ring (NAT'L. 622720)	1
37	NSS	Piston (Order 51130 Control Valve, Item 12)	1
38	45857	Spring	1
39	16308-131	Retaining Ring (SPIROLOX RS-131)	1
40	51154	Spring Stop	1
41	16305-157	Retaining Ring (SPIROLOX RR-156)	1
42	16262-210	O-Ring (NAT'L. 622715)	1
43	NSS	Relief Valve Seat (Order 52652 Relief Valve Kit)	1
44	NSS	Relief Valve Piston (Order 52652 Relief Valve Kit)	1
45	52719	Spring	1
46	51132	Relief Valve Tube	1
47	51133	Retaining Screw	1
48	16044-12	Jam Nut (3/4 UNF)	1
49	51135	Adjusting Screw	1
50	16064-6	Washer (3/8)	2
51	16043-6	Jam Nut (3/8 UNC)	1
52	16044-4	Jam Nut (1/4 UNF)	1
53	51933	Threaded Rod	1
54	16344-1	Rod End	2
55	16047-408	Cap Screw (1/4 UNC x 1)	1
56	16033-4	Nut (1/4 UNC)	1
57	16047-407	Cap Screw (1/4 UNC x 7/8)	1
58	51929	Bell Crank	1
59	16009-6	Thrust Bearing	2
60	16357-0603	Shoulder Screw (3/8 UNC x 3/8)	1
61	51932	Control Cable Pin	1
62	49333-1	Disc Spring	2
63	16064-8	Washer (3/8)	1
64	16288-316	Cotter Pin (3/32 x 1)	1
-	52651	Kit, Valve Spool Repair (Consists of Items 24, 27, 29, 31, 32, 35, 36, 38, 39, 41)	1
-	52652	Kit, Relief Valve Repair (Consists of Items 42, 43, 44, 45, 46)	1
-	52653	Kit, Accumulator Check Valve (Consists of Items 15, 16, 17, 18, 19, 20, 21)	1

CARCO MODEL 60-PS, PSM & PSC WINCH
 PARTS LIST SECTION—PAGE 14
 HYDRAULIC TUBING & FITTINGS
 JI CASE 1450B P.S. TRACTOR

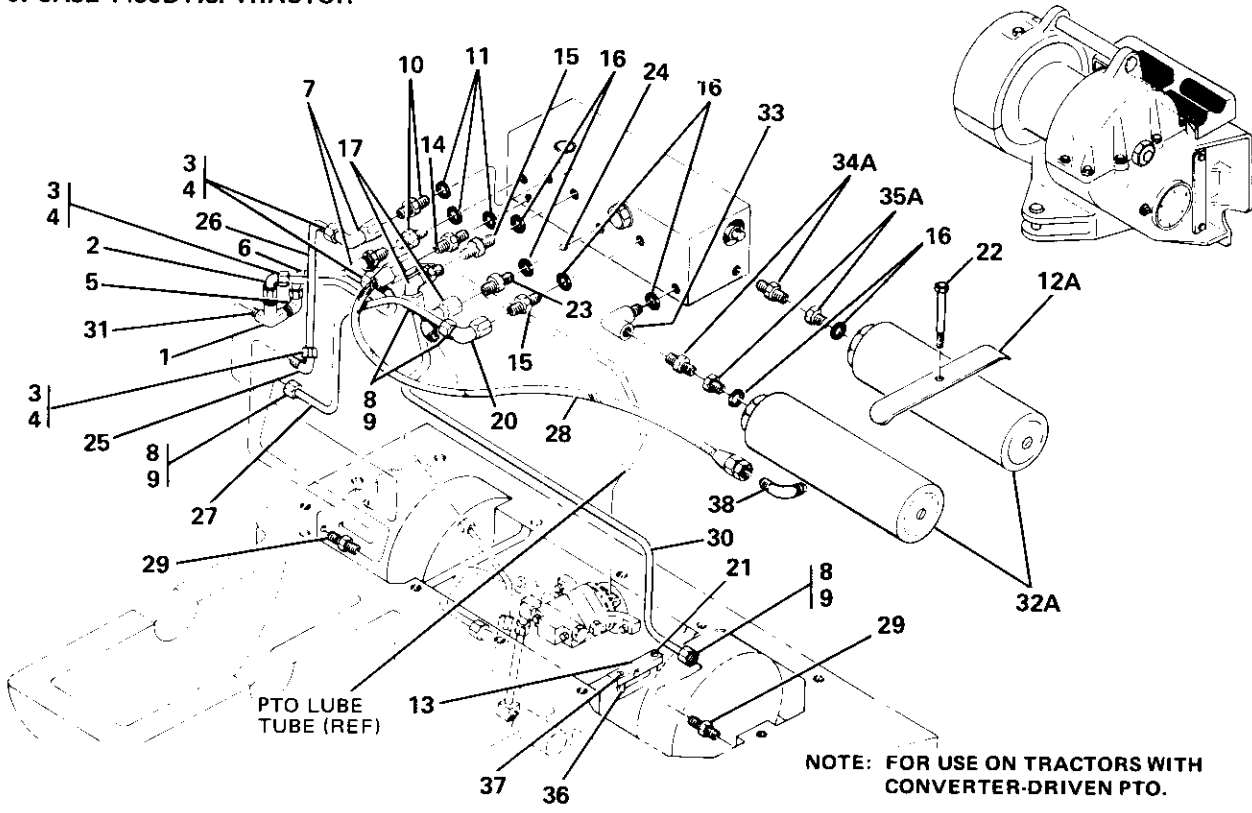

HYDRAULIC TUBING AND FITTINGS 51267

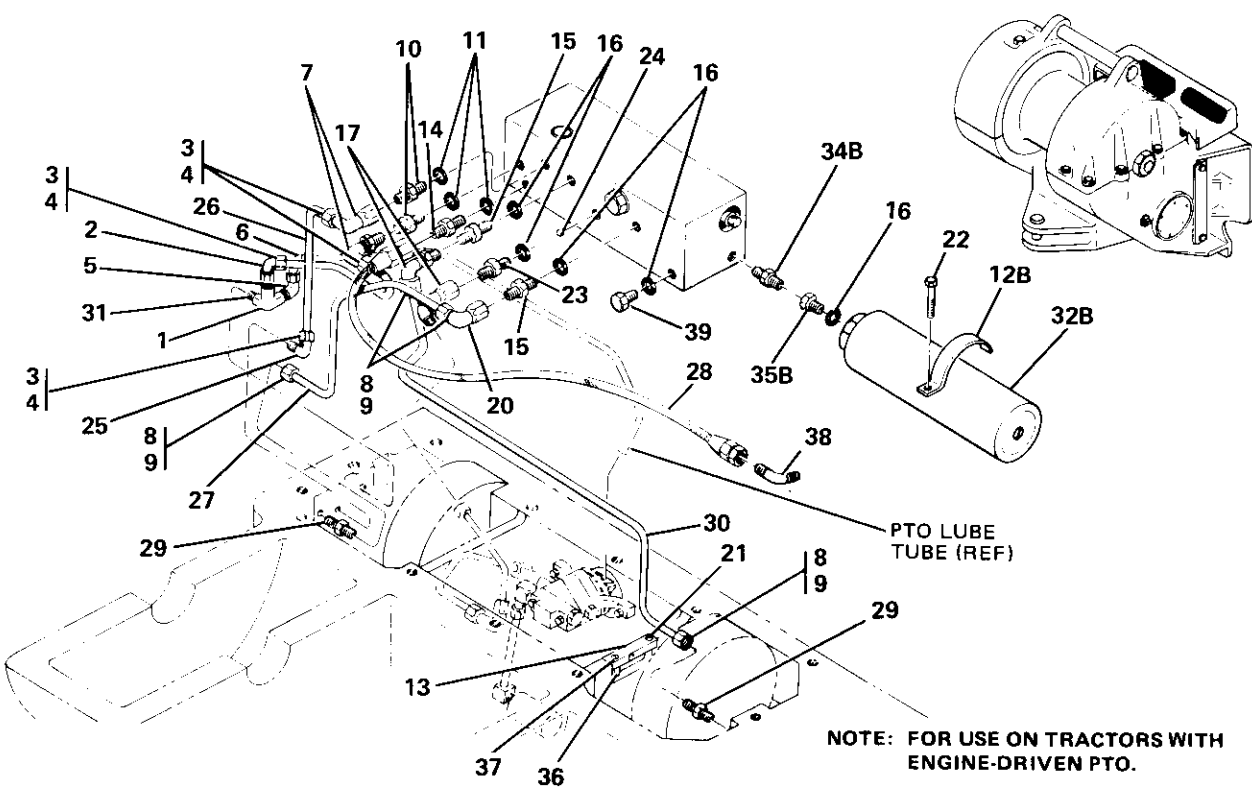

HYDRAULIC TUBING AND FITTINGS 52573

2586-B-10-30-83
 SUPERSEDES
 2586-B-3-15-79

CARCO MODEL 60-PS, PSM & PSC WINCH
PARTS LIST SECTION—PAGE 15
HYDRAULIC TUBING & FITTINGS
JI CASE 1450B P.S. TRACTOR

REF.	CARCO PART NO.	NAME AND DESCRIPTION	QUAN. PER UNIT
1	16497-0004	Elbow (GRINELL 1109)	1
2	16137-0064	Elbow (WTHRD. 7405 x 6)	1
3	16521-06	Nut (PARKER BU6)	4
4	16522-06	Sleeve (PARKER TU6)	4
5	16137-44	Elbow (WTHRD. 7405 x 4 x 4)	1
6	51957-04	Brake Return Tube	1
7	16485-0006	Elbow (WTHRD. 7506 x 6)	2
8	16521-08	Nut (PARKER BU8)	4
9	16522-08	Sleeve (PARKER TU8)	4
10	16481-0006	Connector (WTHRD. 7315 x 6)	2
11	16262-906	O-Ring (NAT'L. 600593)	3
12A	51869	Clamp	1
12B	52594	Clamp	1
13	51868	Plate	1
14	16113-46	Connector (WTHRD. C5315 x 4 x 6)	1
15	16481-8	Connector (WTHRD. 7315 x 8)	2
16	16262-908	O-Ring (NAT'L. 600503)	6
17	16476-8	Elbow (7515 x 8)	1
20	16485-0008	Elbow (WTHRD. 7506 x 8)	2
21	16047-407	Cap Screw (1/4 UNC x 7/8 H.H.)	1
22	16357-0820	Shoulder Screw (1/2 UNC x 2-1/2 Hex. Soc. Hd.)	1
23	52289	Connector	1
24	16471-8	Ball Check	1
25	16137-0066	Elbow (WTHRD. 7405 x 6 x 6)	1
26	51957-01	Brake Pressure Tube	1
27	51958-07	Forward Clutch Tube	1
28	53841-0001	Hose Assembly	1
29	16482-0086	Connector (WTHRD. 7205 x 8)	2
30	51958-10	Reverse Clutch Tube	1
31	16158-407	Nipple (1/4 NPT x 7/8)	1
32A	16475-6	Accumulator (GREER 847110, 150 PSI Nitrogen)	2
32B	16475-7	Accumulator (GREER 847110, 50 PSI Nitrogen)	1
33	16498-0086	Elbow (WTHRD. C3459 x 8)	1
34A	16160-06	Nipple (WTHRD. C3069 x 6)	2
34B	16160-06	Nipple (WTHRD. C3069 x 6)	1
35A	16114-0086	Adapter (WTHRD. C3269 x 8 x 6)	2
35B	16114-0086	Adapter (WTHRD. C3269 x 8 x 6)	1
36	46126-407	Spacer	1
37	16047-414	Cap Screw (1/4 UNC x 1-3/4 H.H.)	1
38	16144-44	Connector (WTHRD. C5355 x 4 x 4)	1
39	52574	Orifice Plug	1

CARCO MODEL 60-PS, PSM & PSC WINCH
 PARTS LIST SECTION—PAGE 16
 PUMP GROUP
 JI CASE 1450B P.S. TRACTOR

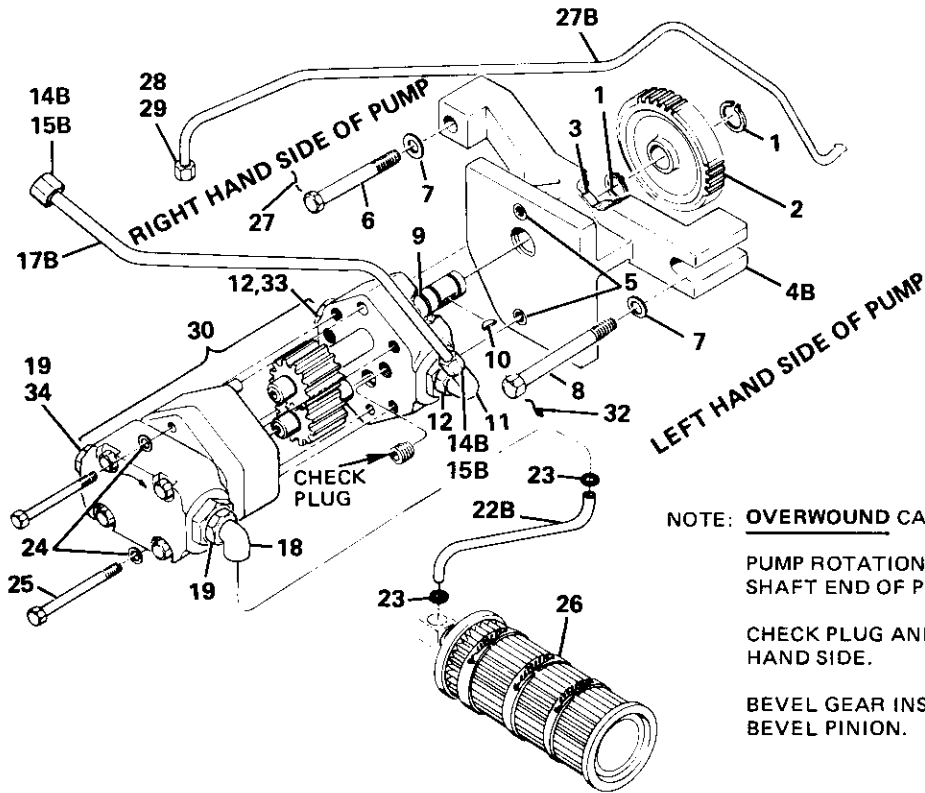

NOTE: OVERWOUND CABLE DRUM
 PUMP ROTATION C.W. AS VIEWED FROM
 SHAFT END OF PUMP.
 CHECK PLUG AND END CAP LOCATION, LEFT
 HAND SIDE.
 BEVEL GEAR INSTALLED ON BRAKE SIDE OF
 BEVEL PINION.

PUMP GROUP 52329-1

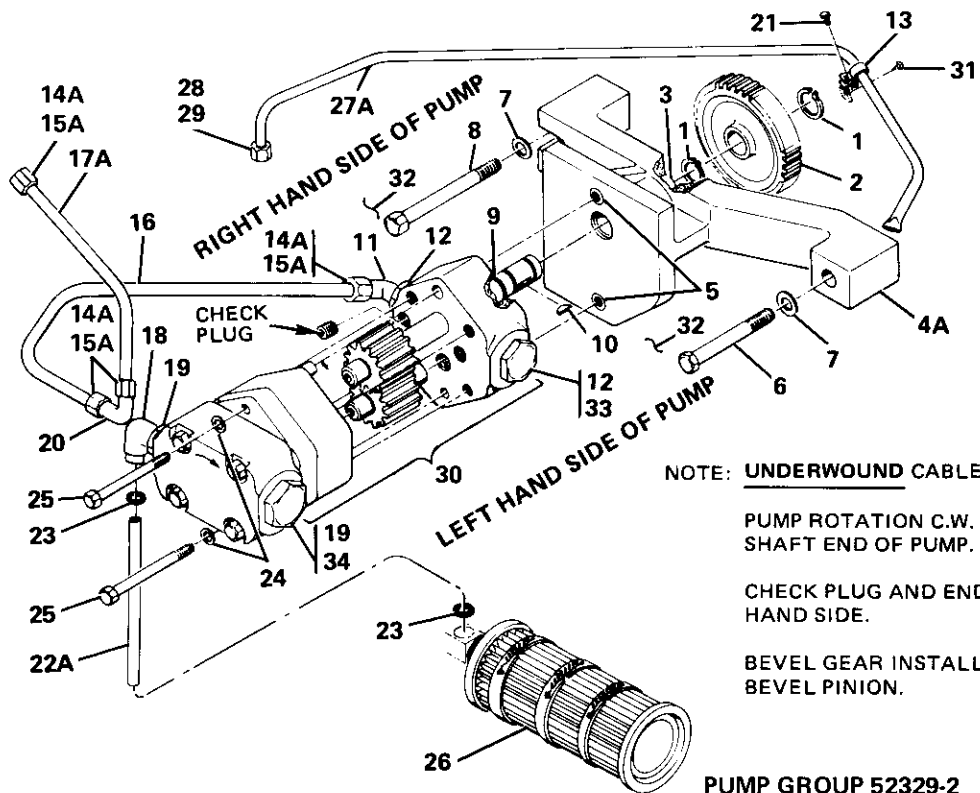

NOTE: UNDERWOUND CABLE DRUM
 PUMP ROTATION C.W. AS VIEWED FROM
 SHAFT END OF PUMP.
 CHECK PLUG AND END CAP LOCATION, RIGHT
 HAND SIDE.
 BEVEL GEAR INSTALLED ON GEAR SIDE OF
 BEVEL PINION.

PUMP GROUP 52329-2

2587-B-10-30-83
 SUPERSEDES
 2587-B-3-15-79

CARCO MODEL 60-PS, PSM & PSC WINCH
PARTS LIST SECTION—PAGE 17
PUMP GROUP
JI CASE 1450B P.S. TRACTOR

REF.	CARCO PART NO.	NAME AND DESCRIPTION	QUAN. PER UNIT
1	16313-62	Ring, Retaining (TRUARC 5100-62)	2
2	51531-1	Gear	1
3	15305	Bearing, Needle	1
4A	51525-1	Mount Assembly (Includes Items 3 and 5)	1
4B	51526-1	Mount Assembly	1
5	16507-0003	Insert, Threaded	2
6	16024-15	Cap Screw (3/8 UNC x 1-3/4 Dr. Hd.)	1
7	16348-1	Washer (CARR LANE CL-1-FW)	2
8	16024-16	Cap Screw (3/8 UNC x 2-1/4 Dr. Hd.)	1
9	16284-95	Seal, Pump Shaft (WEBSTER 151-35818)	1
10	16226-7	Key (WOODRUFF No. 3, 1/8 x 1/2)	1
11	16476-8	Elbow (WTHRD. 7515 x 8)	1
12	16262-908	O-Ring (NAT'L. 600503)	2
13	16520-01	Clamp, Swivel (ADEL 1789-X4-4)	1
14A	16521-08	Nut (PARKER BU8)	4
14B	16521-08	Nut	2
15A	16522-08	Sleeve (PARKER TU8)	4
15B	16522-08	Sleeve	2
16	51958-13	Tube, Pump	1
17A	51958-02	Tube, Pressure	1
17B	51958-01	Tube, Pressure	1
18	16474-12	Elbow (LENZ A-405-12)	1
19	16262-912	O-Ring (NAT'L. 600501)	2
20	16509-08	Elbow (WTHRD. 7505 x 8)	1
21	16021-3	Screw (10-24 UNC x 5/8 Rd. Hd.)	1
22A	51959-52	Tube, Suction	1
22B	51959-51	Tube, Suction	1
23	16262-116	O-Ring (NAT'L. 622714)	2
24	16069-4	Washer, Lock (1/4 Ext. Tooth)	2
25	16047-428	Cap Screw (1/4 UNC x 3-1/2 H.H.)	2
26	16473	Filter (MARVEL 620-5-M-200)	1
27A	51956-05	Tube, PTO Lube	1
27B	51956-12	Tube, PTO Lube	1
28	16521-04	Nut (PARKER BU4)	1
29	16522-04	Sleeve (PARKER TU4)	1
30	53139	Pump (WEBSTER, CW rotation)	1
31	16055-15	Screw, Tapping (1/4 x 1/2)	1
32	NSS	Lock Wire (16 Ga. x 18")	1
33	16188-8	Plug, Boss with O-Ring	1
34	16166-12	Plug, Boss with O-Ring	1

CARCO MODEL 60-PS, PSM & PSC WINCH
 PARTS LIST SECTION—PAGE 18
 BEVEL GEAR SHAFT
 JI CASE 1450B P.S. TRACTOR

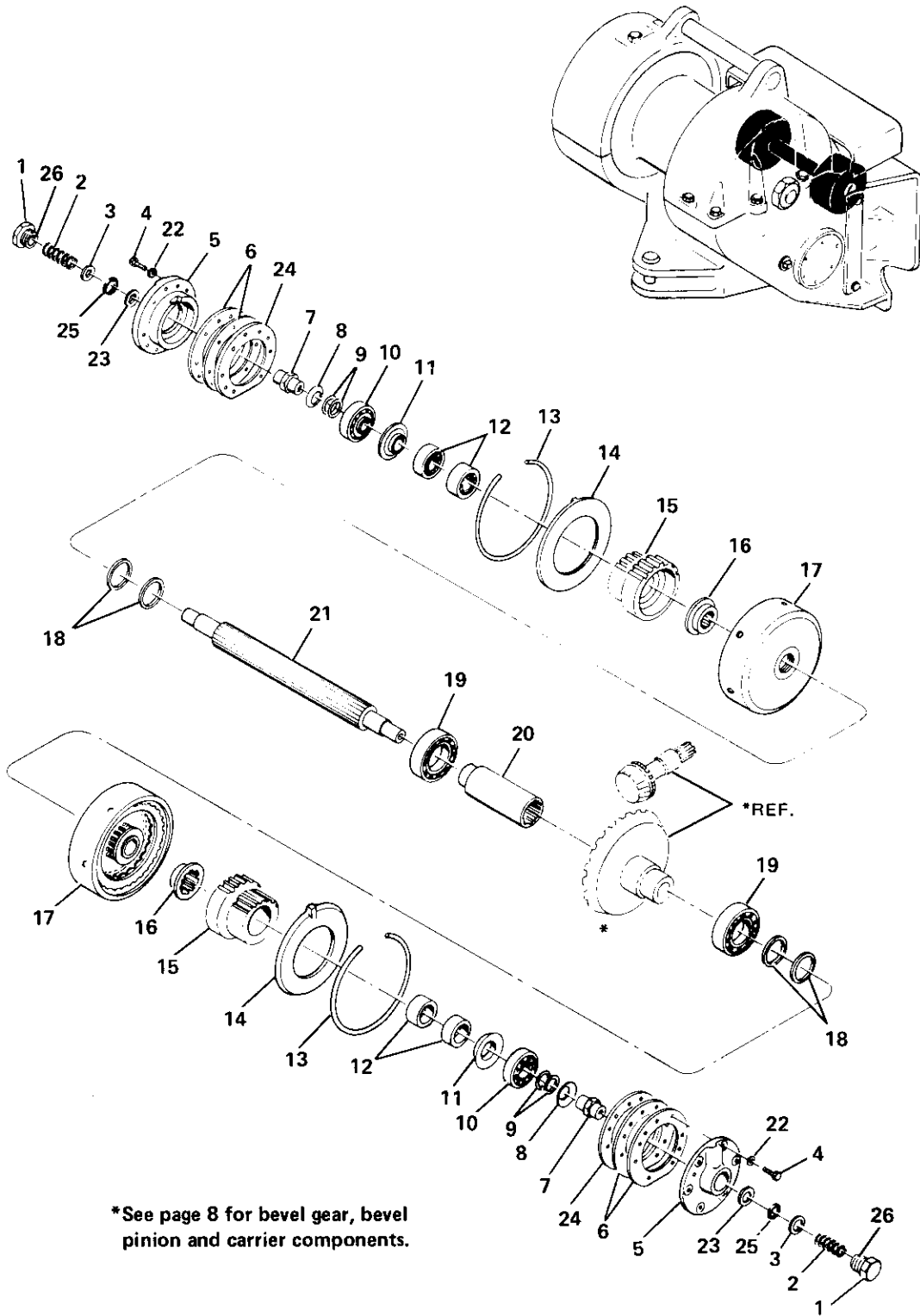

BEVEL GEAR SHAFT GROUP

2588-B-10-30-83
 SUPERSEDES
 2588-B-3-15-79

CARCO MODEL 60-PS, PSM & PSC WINCH
PARTS LIST SECTION—PAGE 19
BEVEL GEAR SHAFT

REF.	CARCO PART NO.	NAME AND DESCRIPTION	QUAN. PER UNIT
1	16166-20	Plug, W/O ring (PARKER 05PO-20)	2
2	44753	Spring	2
3	44949	Seal (Includes Item 25)	2
4	16047-810	Cap Screw (1/2 UNC x 1-1/4)	12
5	44432	Retainer	2
6	44431	Shim Set	2
7	41742	Shaft (S.N. 6-2235 and below)	2
	53221	Shaft (S.N. 6-2236 and up)	2
8	44478	Clamp Ring	2
9	44336	Shim Set	2
10	{ 15179	Bearing Cup	2
	{ 15180	Bearing Cone	2
11	45018	Thrust Washer	2
12	15253	Bearing Set	2
13	44446	Retaining Ring	2
14	44343	Retaining Ring	2
15	48864	Pinion	2
16	45017	Thrust Washer	2
17	51271-1	Clutch Assembly (Includes Items 13 and 14) (See page 20 for clutch components)	2
18	44452	Static Seal	4
19	15030	Ball Bearing	2
20	44451	Spacer	
21	{ 44433	Shaft (S.N. 6-2235 and below), Sub 53625 and 2 - 53321 (Item 7)	
	{ 53625	Shaft, Bevel Gear (S.N. 6-2236 and up)	1
22	16064-8	Washer (1/2)	12
23	44940	Washer	2
24	45028	Gasket	2
25	16262-121	O-Ring (NAT'L. 610067)	2
26	16262-920	O-Ring (NAT'L. 600602)	2

CARCO MODEL 60-PS, PSM & PSC
 PARTS LIST SECTION—PAGE 20
 CLUTCH ASSEMBLY

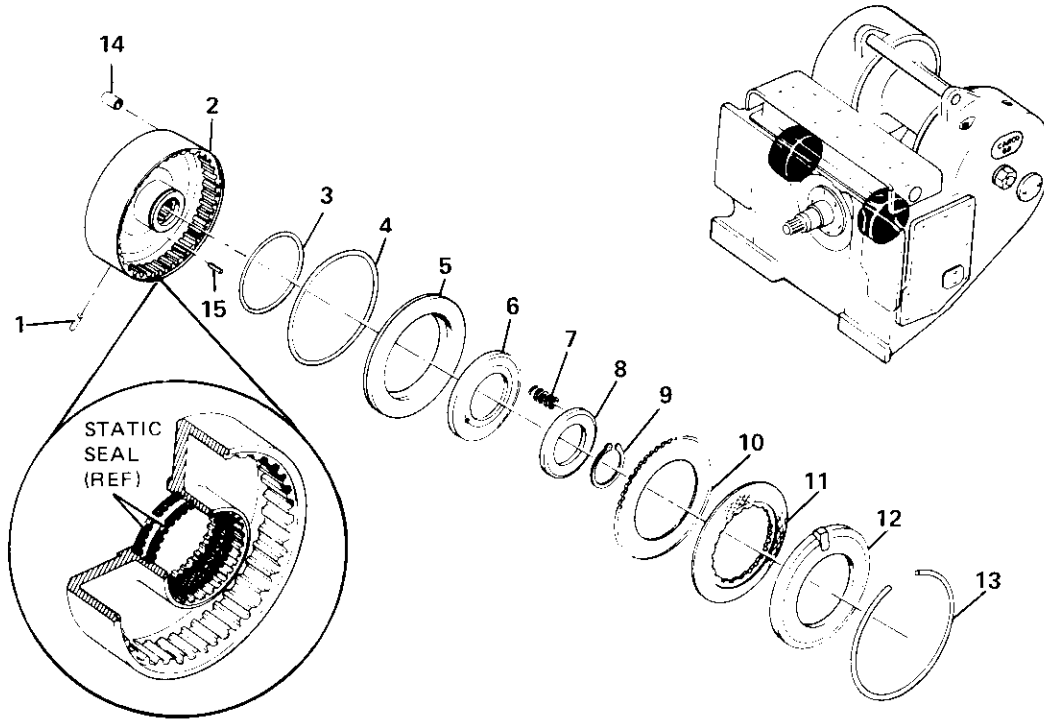

CLUTCH ASSEMBLY

REF.	CARCO PART NO.	NAME AND DESCRIPTION	QUAN. PER UNIT
1	16290-808	Dowel Pin (1/4 x 1/2)	1
2	51270-1	Housing (Includes Items 1 and 14)	1
3	46242	Seal	1
4	46243	Seal	1
5	44445	Piston	1
6	44450	Ring	1
7	44449	Spring	16
8	44448	Retainer	1
9	16313-287	Retaining Ring (TRUARC 5100-287)	1
10	46134	Steel Disc (External Splines)	5
11	46133	Friction Disc (Internal Splines)	4
12	44343	Retaining Ring	1
13	44446	Retaining Ring	1
14	52593	Seat Assembly	1
15	16295-1424	Pin (SPIROL 437-1500-H-B-K)	1
—	51271-1	Clutch Assembly (Consists of all above items)	1

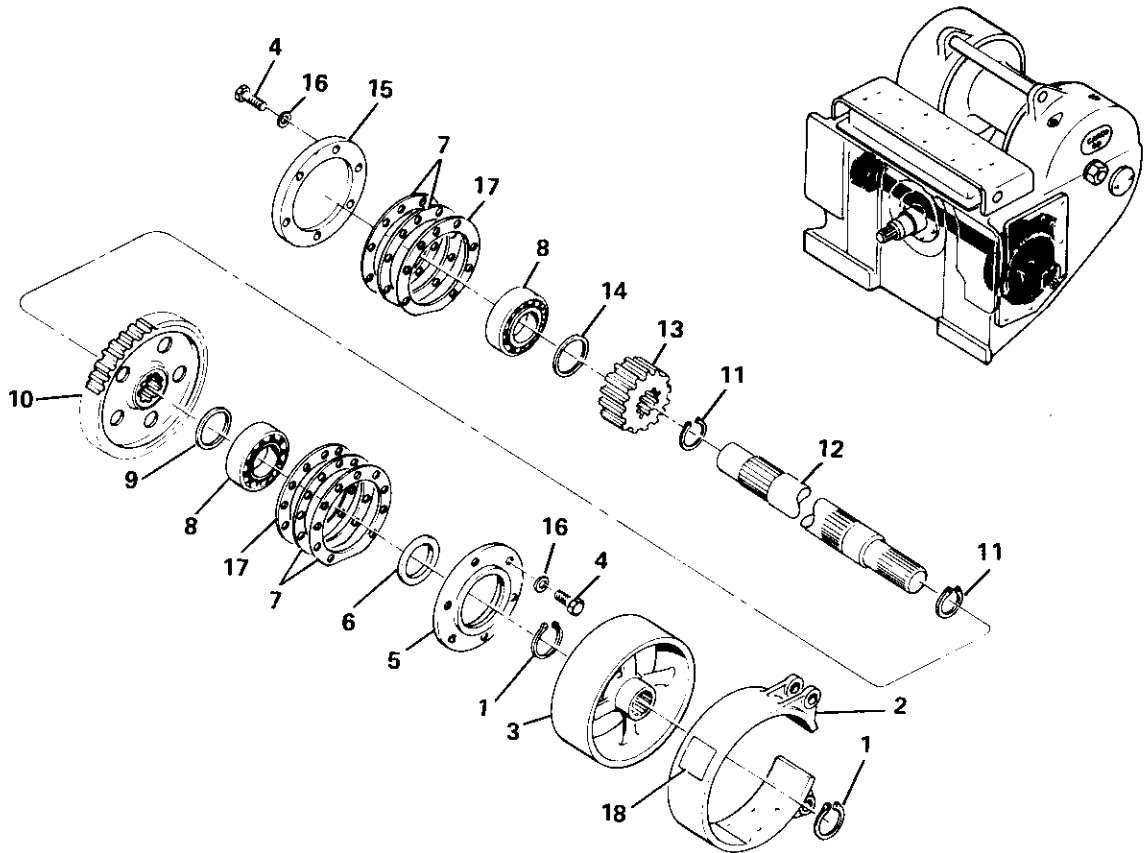

BRAKE SHAFT GROUP NO. 52052

REF.	CARCO PART NO.	NAME AND DESCRIPTION	QUAN. PER UNIT
1	16313-200	Retaining Ring (TRUARC 5100-200)	2
2	46602	Brake Band Assembly (includes following)	1
	46603	Brake Block	3
	16323-808	Rivet (1/4 x 1/2 Tub. Brass)	30
3	44420	Brake Drum	1
4	16047-810	Cap Screw (1/2 UNC x 1-1/4 H.H.)	12
5	44435	Carrier	1
6	16342-1	Oil Seal (NAT'L. 415659)	1
7	44431	Shim Set	2
8	15074	Ball Bearing	2
9	44463-2	Spacer	1
10	44436	Gear	1
11	16313-231	Retaining Ring (TRUARC 5100-231)	2
12	44434	Brake Shaft	1
13	45012	Pinion	1
14	44463-1	Spacer	1
15	44464	Cover	1
16	16064-8	Washer (1/2)	12
17	45028	Gasket	2
18	51955	Asbestos Warning Plate	1

CARCO MODEL 60-PS, PSM & PSC WINCH
 PARTS LIST SECTION—PAGE 22
 IDLER SHAFT GROUP

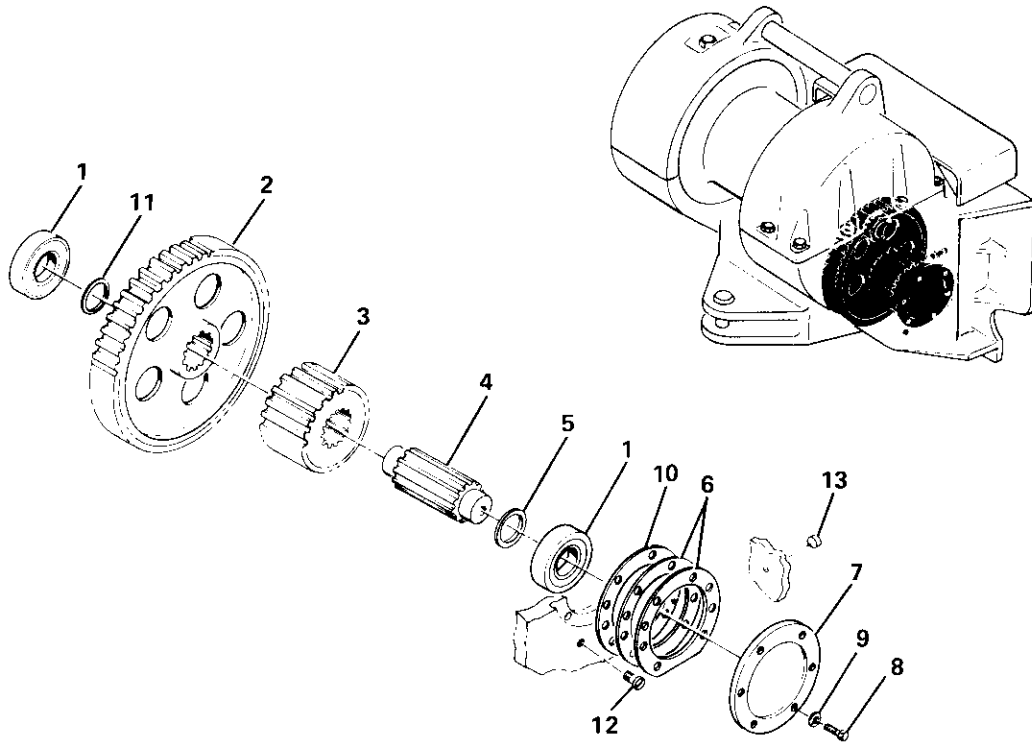

IDLER SHAFT GROUP (NO FREE SPOOL) 52061-1

REF.	CARCO PART NO.	NAME AND DESCRIPTION	QUAN. PER UNIT
1	15296	Bearing, Roller	2
2	44468	Gear	1
3	44465	Pinion	1
4	48904	Shaft	1
5	44467	Spacer	1
6	44431	Shim Set	1
7	44464	Cover	1
8	16047-810	Cap Screw (1/2 UNC x 1-1/4 H.H.)	6
9	16064-8	Washer (1/2)	6
10	45028	Gasket	1
11	48906-1	Spacer	1
12	50475	Plug	1
13	16540-0001	Plug, Cup Expansion (1-1/8)	1

CARCO MODEL 60-PS, PSM & PSC WINCH
 PARTS LIST SECTION—PAGE 23
 CABLE DRUM GROUP (NO FREE SPOOL)

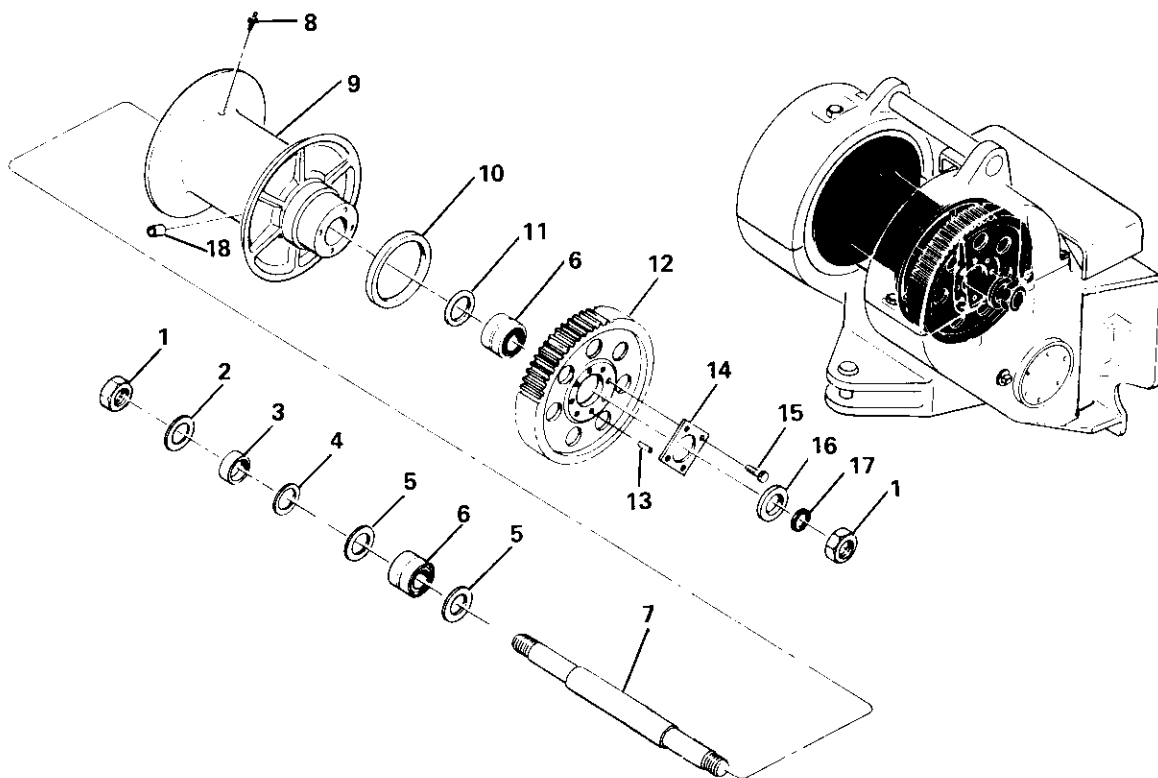

CABLE DRUM GROUP 52033

REF.	CARCO PART NO.	NAME AND DESCRIPTION	QUAN. PER UNIT
1	16044-40	Nut (2-1/2 UNF Hex Jam)	2
2	16343-21	Oil Seal (NAT'L. 455379)	1
3	44457-2	Spacer	1
4	44881	Shim	2
5	44458	Seal Washer	2
6	15200	Bearing Set	2
7	44459	** Shaft, Cable Drum	1
8	16222-2	Grease Fitting (ALEMITE 1610BL)	1
9	{ 44456 44682	Standard Drum (PS and PSM) High Capacity Drum (Standard on PSC)	1 1
10	16342-10	Oil Seal (NAT'L. 415300)	1
11	16343-16	Oil Seal (NAT'L. 455137)	1
12	44461	Gear	1
13	45081-2	* Dowel Pin	4
14	44469	Lock	1
15	16048-1218	Cap Screw (3/4 UNF x 2-1/4)	4
16	44460-2	Spacer	1
17	16262-332	O-Ring (NAT'L. 622735)	1
18	{ 25457-3 25457-2 25457-1	Ferrule (1") Ferrule (7/8") Ferrule (3/4")	1 1 1

NOTES:

*When bull gear or cable drum is replaced, dowel holes must be drilled 5/64" and reamed .9057"/.9077" to accommodate oversize 45081-2 dowels.

**For extended drum shaft order 46925 shaft and 2 each 10641-14 nut, Timken TN 14.

CARCO MODEL 60-PS, PSM & PSC WINCH
 PARTS LIST SECTION—PAGE 24
 FREE SPOOL IDLER SHAFT

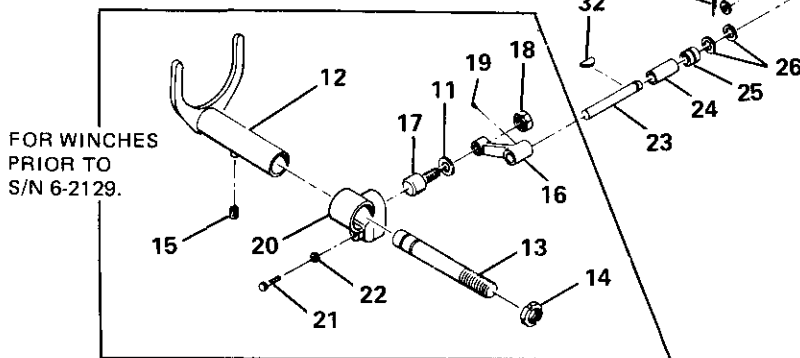
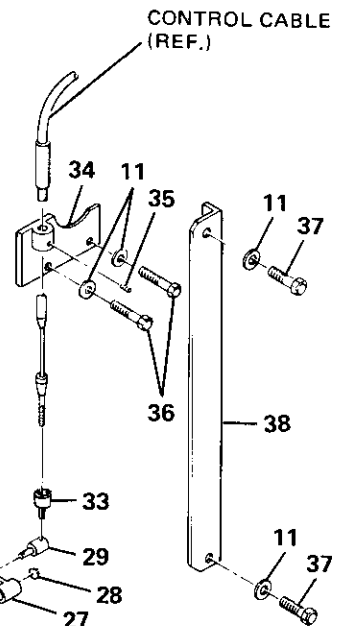
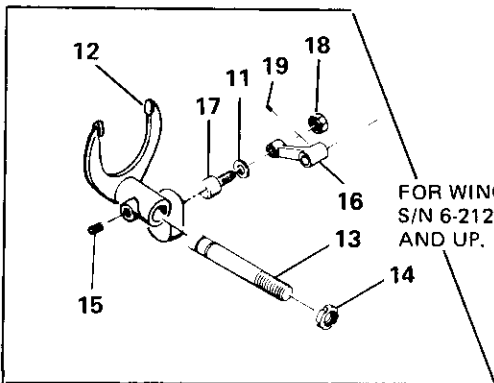
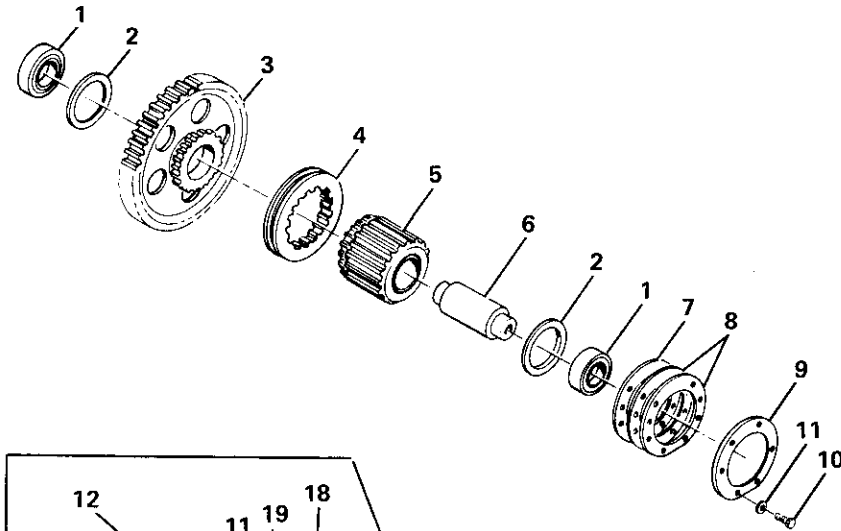
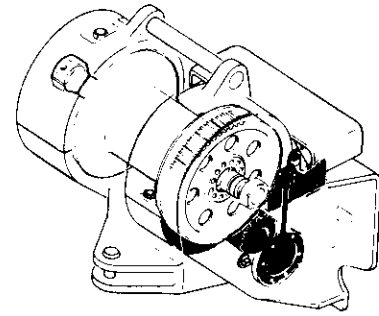

FREE SPOOL IDLER SHAFT GROUP 52062

CARCO MODEL 60-PS, PSM & PSC WINCH
PARTS LIST SECTION—PAGE 25
FREE SPOOL IDLER SHAFT

REF.	CARCO PART NO.	NAME AND DESCRIPTION	QUAN. PER UNIT
1	15296	Bearing	2
2	49953	Washer, Thrust	2
3	49954	Gear, Idler	1
4	49943	Coupling	1
5	53533-60	Pinion Assy, w/Bushing	1
6	49955	Shaft, Idler	1
7	45028	Gasket	1
8	44431	Shim Set	1
9	44464	Cover	1
10	16047-810	Cap Screw (1/2 UNC x 1-1/4)	6
11	16064-8	Washer (1/2)	10
12	49944-50	Fork Assy, Shift (S.N. 6-2128 and below), Sub 53586 and 53458 (item 16)	1
	53586	Fork Assy, Shift (S.N. 6-2129 and up)	1
13	49940-50	Guide	1
14	16041-6	Nut, Lock (TIMKEN TN-06)	1
15	16403-2	Ball Plunger	1
16	49949	Lever, Shift (S.N. 6-2128 and below)	1
	53458	Lever, Shift (S.N. 6-2129 and up)	1
17	16404-14	Cam Follower	1
18	16044-6	Nut (3/8 UNF Hex Jam)	1
19	16056-612	Set Screw (3/8 UNC x 3/4)	1
20	49947	Cam, Shift (S.N. 6-2128 and below)	1
21	16047-608	Cap Screw (3/8 UNC x 1) (S.N. 6-2128 and below)	1
22	16067-6	Washer, Lock (S.N. 6-2128 and below)	1
23	52439	Shaft, Shifter	1
24	16006-21	Bushing	2
25	16342-19	Oil Seal (NAT'L. 410791)	2
26	16064-10	Washer (5/8)	1
27	49941-50	Lever, Control	1
28	16313-62	Retaining Ring (TRUARC 5100-62)	1
29	49332	Pin, Cable	1
30	49333-1	Spring, Disc	1
31	16292-616	Pin, Spring (3/16 x 1)	1
32	16226-1	Key (WOODRUFF 5/32 x 5/8)	1
33	52399	Adapter, Cable	1
34	49952-11	Bracket	1
35	16056-606	Set Screw (3/8 UNC x 3/8)	2
36	16047-812	Cap Screw (1/2 UNC x 1-1/2)	2
37	16047-806	Cap Screw (1/2 UNC x 3/4)	1
38	49956	Guard, Cable	

CARCO MODEL 60-PS, PSM & PSC WINCH
 PARTS LIST SECTION—PAGE 26
 CABLE DRUM GROUP W/FREE SPOOL

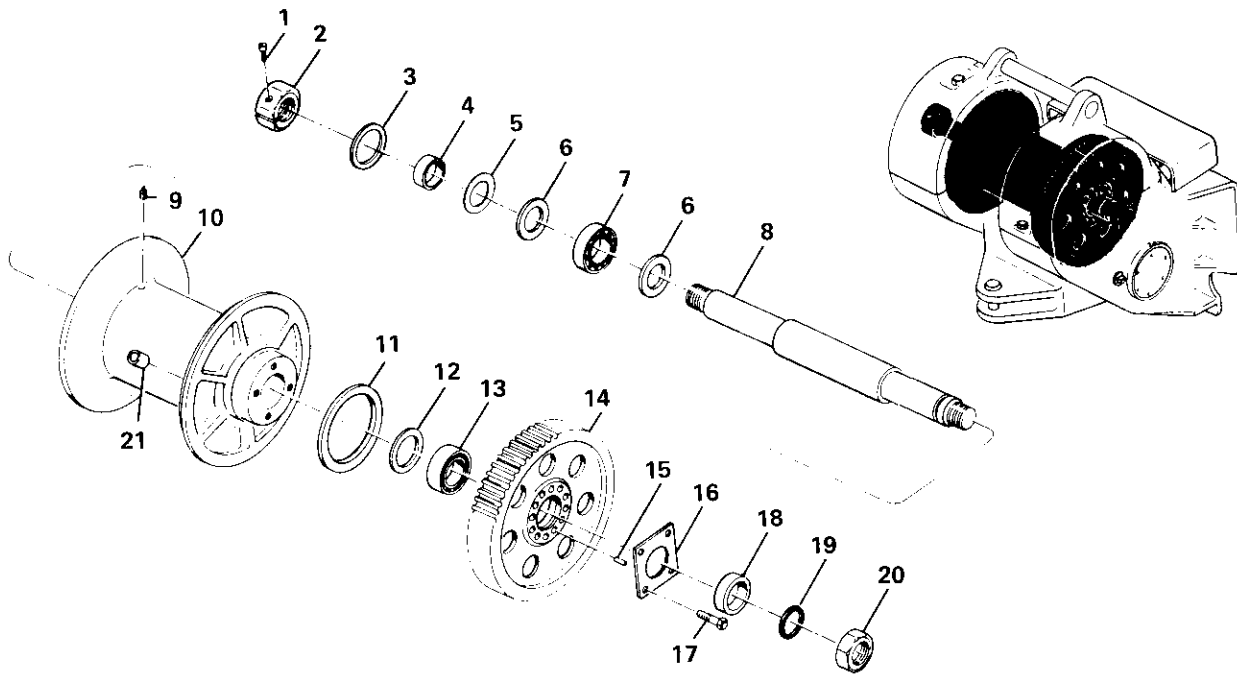

FREE SPOOL CABLE DRUM GROUP

REF.	CARCO PART NO.	NAME AND DESCRIPTION	QUAN. PER UNIT
1	16045-712	Screw, Self-Lock (7/16 UNF x 1-1/2 Hex. Soc. Hd.)	1
2	49957-40	Nut, Split	1
3	16343-21	Oil Seal (NAT'L. 455379)	1
4	44457-2	Spacer	1
5	44881	Shim	2
6	44458	Washer	2
7	15299	Bearing Set	1
8	44459	** Shaft, Cable Drum	1
9	16222-2	Grease Fitting (ALEMITE 1610 BL)	1
10	44456	Cable Drum, Standard	1
	44682	Cable Drum, High Capacity	1
11	16342-10	Oil Seal (NAT'L. 415300)	1
12	16343-16	Oil Seal (NAT'L. 455137)	1
13	15200	Bearing Set	1
14	44461	Gear, Cable Drum	1
15	45081-2	* Dowel Pin	4
16	44469	Lock Plate	1
17	16048-1218	Cap Screw (3/4 UNF x 2-1/4)	4
18	44460-2	Spacer	1
19	16262-332	O-Ring (NAT'L. 622735)	1
20	16044-40	Nut (2-1/2 UNF Hex Jam)	1
	25457-3	Ferrule (1)	1
21	25457-2	Ferrule (7/8)	1
	25457-1	Ferrule (3/4)	1

NOTES:

*When bull gear or cable drum is replaced, dowel holes must be drilled 5/64" and reamed .9057"/.9077" to accommodate oversize 45081-2 dowels.

**For extended drum shaft order 46925 shaft and 2 each 10641-14 nut, Timken TN 14.

CARCO MODEL 60-PS, PSM & PSC WINCH
PARTS LIST SECTION—PAGE 27
BRAKE CONTROL (MANUAL)

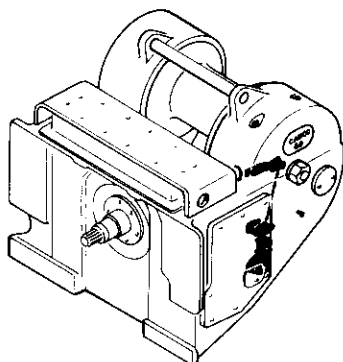

NOTE:

*DIAGRAM SHOWS PINS (ITEMS 5 AND 6) IN LOCATIONS FOR OVERWIND CABLE DRUM OPERATIONS.

REVERSE LOCATION OF PINS (ITEMS 5 AND 6) WHEN CONVERTING WINCH TO UNDERWOUND.

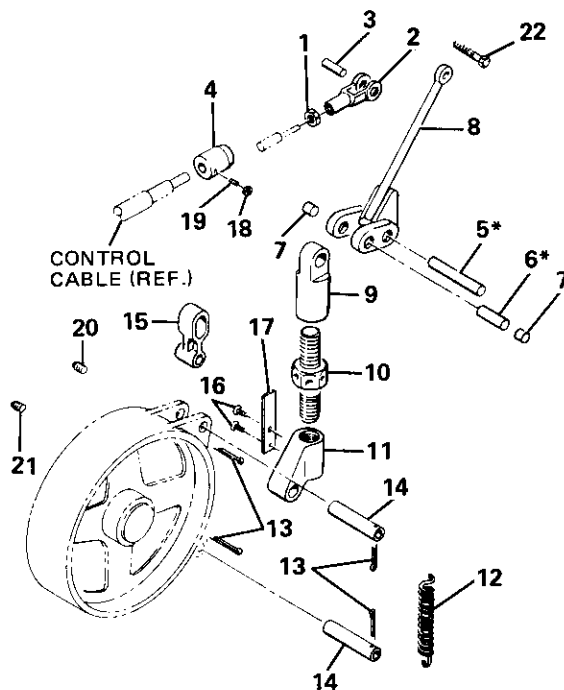

MANUAL BRAKE CONTROL GROUP NO. 52073

REF.	CARCO PART NO.	NAME AND DESCRIPTION	QUAN. PER UNIT
1	16044-6	Nut (3/8 UNF Hex Jam)	1
2	16245-6	Yoke (CLEVELAND 2708-4A)	1
3	16246-6	Pin (CLEVELAND 2708-1/2-4A)	1
4	45351-1	Anchor	1
5	44428	Pin	1
6	44429	Pin	1
7	44687-2	Spacer	2
8	44984	Arm	1
9	44426-1	Rod Nut	1
10	44423	Rod	1
11	44422-1	Rod Nut	1
12	44107	Spring	1
13	16288-420	Cotter Pin (1/8 x 1-1/4)	4
14	44421	Pin	2
15	44427	Link	1
16	16055-5	Drive Screw (#10 x 3/8 Type U)	2
17	44806	Spring	1
18	16043-6	Nut (3/8 UNC Hex Jam)	1
19	16056-612	Set Screw (3/8 UNC x 3/4 Hex Soc.)	1
20	16169-6	Plug (3/8 NPT Sq. Hd.)	1
21	16169-4	Plug (1/4 NPT Sq. Hd.)	1
22	16047-1232	Cap Screw (3/4 UNC x 4 H.H.)	1

NOTE: See pages 6 & 7 for control stand group.

CARCO MODEL 60-PS, PSM & PSC WINCH
 PARTS LIST SECTION—PAGE 28
 BRAKE CONTROL (SPRING APPLIED)

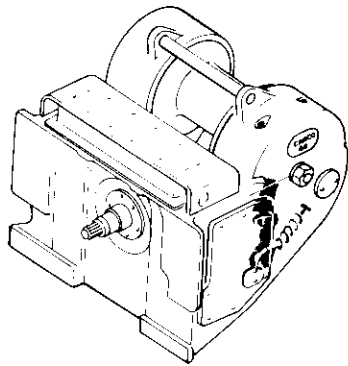

NOTE:

*DIAGRAM SHOWS PINS (ITEMS 7 AND 15) IN LOCATIONS FOR OVERWIND CABLE DRUM OPERATIONS.

REVERSE LOCATION OF PINS (ITEMS 7 AND 15) WHEN CHANGING WINCH TO UNDERWOUND.

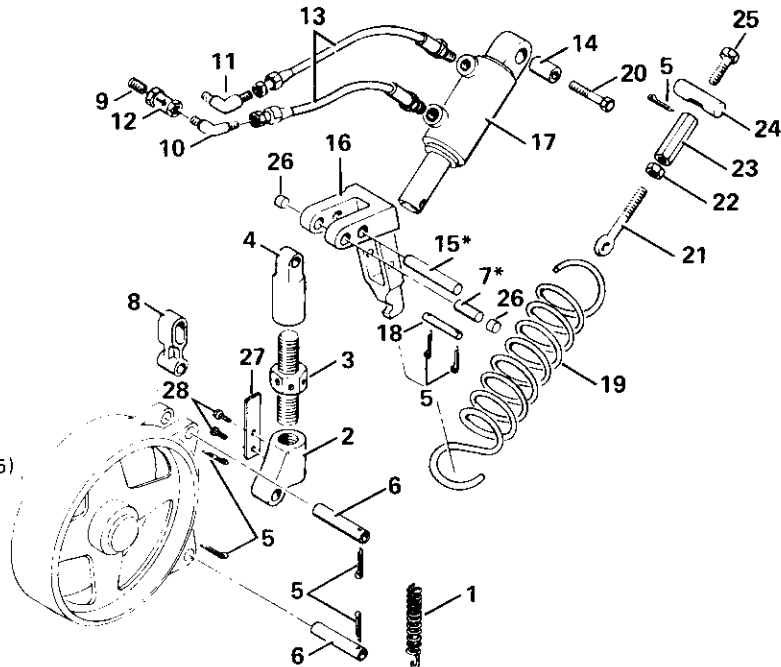

P.S. BRAKE CONTROL GROUP (SPRING APPLIED) NO. 52072

REF.	CARCO PART NO.	NAME AND DESCRIPTION	QUAN. PER UNIT
1	44107	Spring	1
2	44422-1	Rod Nut	1
3	44423	Rod	1
4	44426-1	Rod Nut	1
5	16288-420	Cotter Pin (1/8 x 1-1/4)	7
6	44421	Pin	2
7	44429	Pin	1
8	44427	Link	1
9	16158-407	Nipple (1/4 NPT x 1)	1
10	16145-46	Elbow (WTHRD. C5405 x 6)	1
11	16145-66	Elbow (WTHRD. C5405 x 6 x 6)	1
12	51278	Flow Control Valve	1
13	44118-13	Hose	2
14	46077-1	Sleeve	1
15	44428	Pin	1
16	44437	Arm	1
17	51279	Cylinder (See Page 29)	1
18	44438	Pin	1
19	40155	Spring	1
20	16047-1232	Cap Screw (3/4 UNC x 4)	1
21	44206	Eye Bolt	1
22	16043-8	Nut (1/2 UNC Hex Jam)	1
23	40174	Nut	1
24	40175	Pin	1
25	42023	Screw	1
26	44687-2	Spacer	2
27	44806	Spring	1
28	16055-5	Drive Screw (#10 x 3/8)	2

NOTE: See pages 4 & 5 for control stand group.

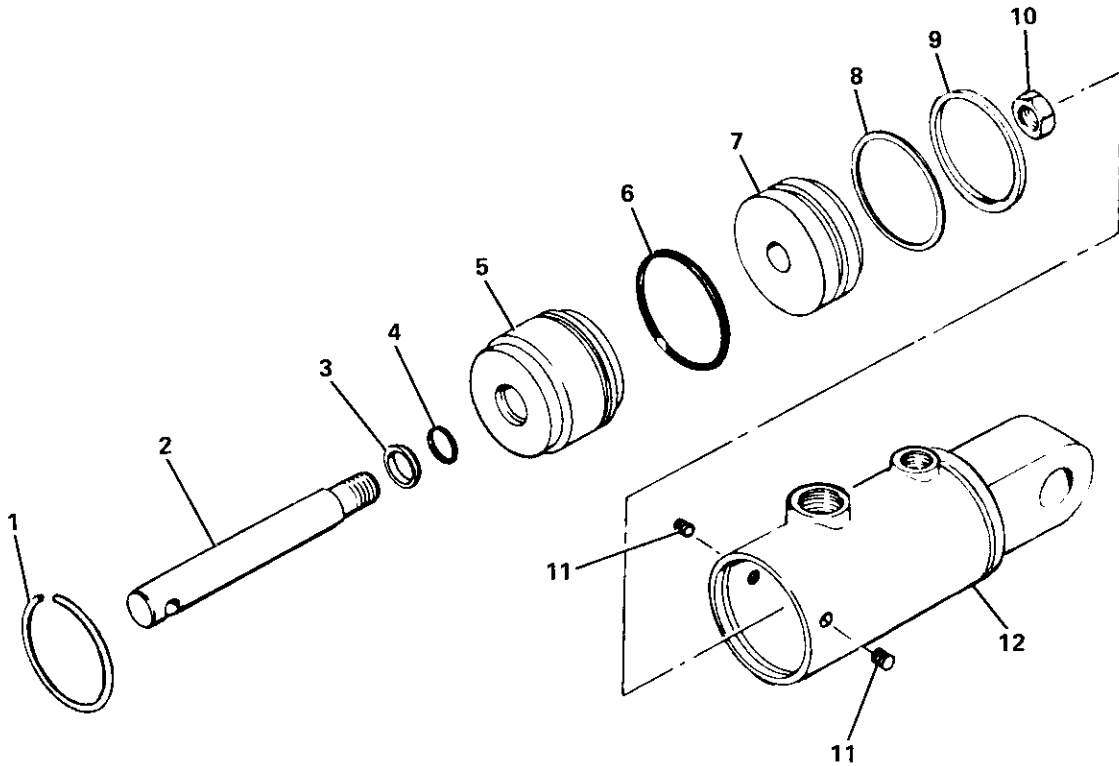

BRAKE CYLINDER ASSEMBLY

REF.	CARCO PART NO.	NAME AND DESCRIPTION	QUAN. PER UNIT
1	16280-6	Retaining Ring	1
2	16280-4	Rod, Piston	1
3	16280-7	Wiper	1
4	16262-214	O-Ring (NAT'L. 622719)	1
5	16280-2	Head	1
6	16262-228	O-Ring (NAT'L. 623006)	1
7	16280-15	Piston	1
8	16301-1	Washer, Back-up	1
9	16334-1	Seal (C/R 710087)	1
10	16280-5	Nut	1
11	16054-404	Set Screw (1/4 UNC x 1/4)	2
12	NSS	Tube Assy (Order 51279 Brake Cylinder)	1
--	46241	Repair Kit, Seal (Consists of Items 3, 4, 6, 8, 9)	1
--	51279	Brake Cylinder Assembly	1

CARCO MODEL 60-PS, PSM & PSC WINCH
 PARTS LIST SECTION—PAGE 30
 POWERSHIFT CONTROL STAND

CONTROL STAND (POWERSHIFT)
 49001-01 THROUGH 49001-08*
 CONTROL STAND
 (POWER SHIFT W/MANUAL BRAKE)
 53598-01 THROUGH 53598-08*

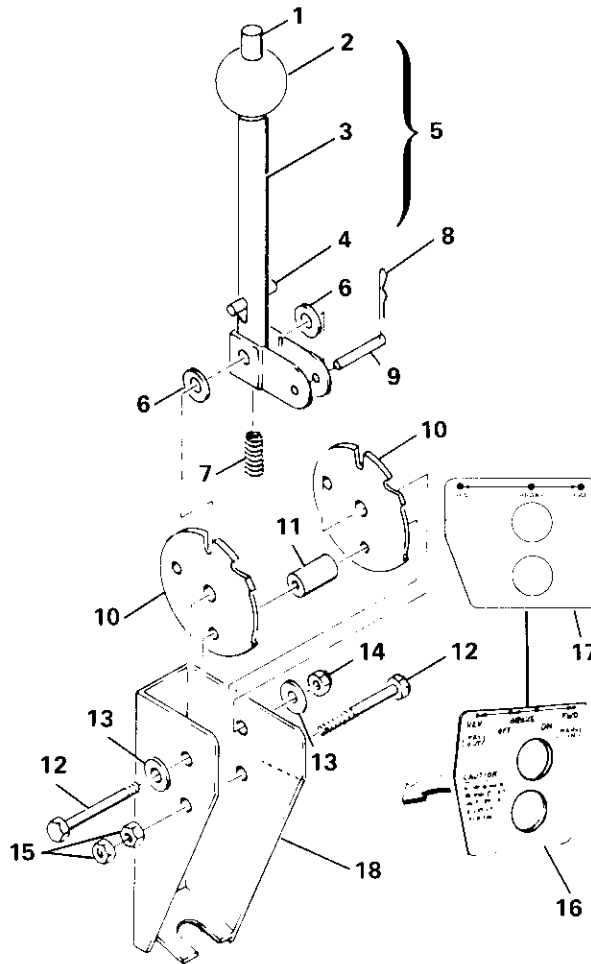

REF.	CARCO PART NO.	NAME AND DESCRIPTION	QUAN. PER UNIT
1	49004	Push Rod	1
2	41404	Ball	1
3	49005	Handle	1
4	16294-824	Pin, Spring (1/4 x 1-1/2)	1
5	49003	Lever Assy (Consists of Items 1, 2, 3, 4)	1
6	16009-6	Bearing, Thrust (BUNTING TW-37)	2
7	41403	Spring	1
8	16381-13	Pin, Hitch	1
9	49010	Pin	1
10	49007	Plate, Lock	2
11	49804-3	Spacer	1
12	16047-620	Cap Screw (3/8 UNC x 2-1/2)	2
13	16064-6	Washer (3/8)	2
14	16039-66	Nut, Lock (3/8)	1
15	16033-6	Nut (3/8 Hex)	2
16	49314	Plate, Instruction, Powershift	1
17	53362-2	Plate, Instruction, Powershift w/Manual Brake	1
18	NSS	* Housing, Powershift (Order Control Stand Assembly)	1

*Refer to Control Group, pages 4 and 6 for part number of complete Control Stand Assembly.

CARCO MODEL 60-PS, PSM & PSC WINCH
PARTS LIST SECTION—PAGE 31
POWERSHIFT W/FREE SPOOL CONTROL STAND

CONTROL STAND
(POWERSHIFT/FREE SPOOL)
49805-01 THROUGH 49805-09*

CONTROL STAND
(POWERSHIFT/FREE SPOOL
W/MANUAL BRAKE)
53599-01 THROUGH 53599-09*

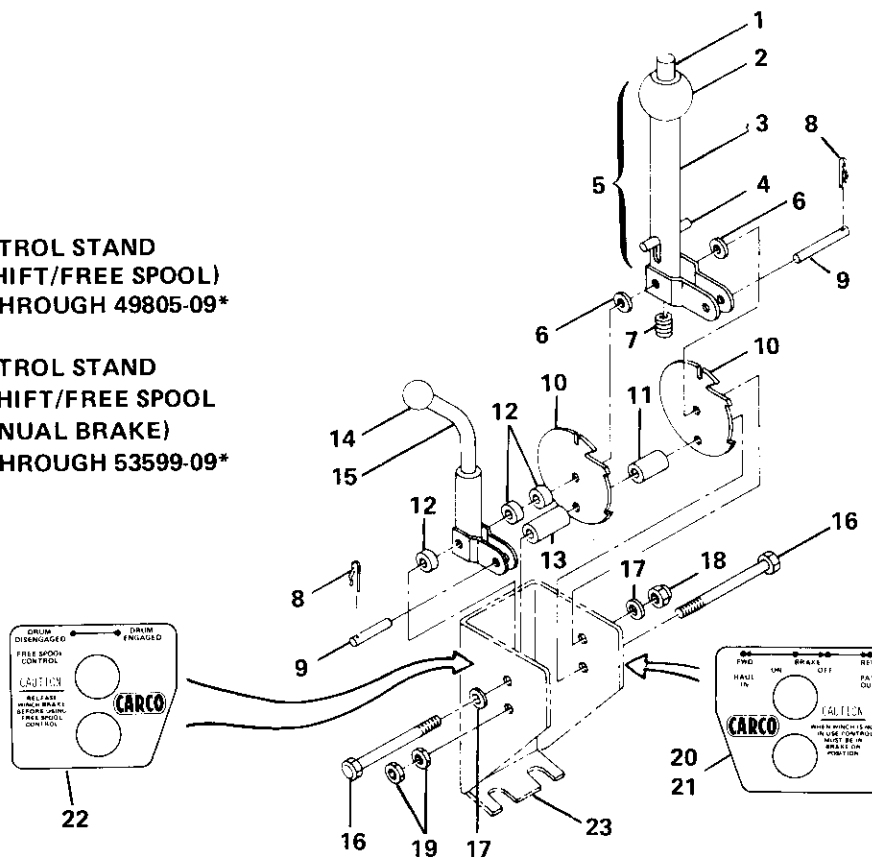

REF.	CARCO PART NO.	NAME AND DESCRIPTION	QUAN. PER UNIT
1	49004	Push Rod	1
2	41404	Ball	1
3	49005	Handle	1
4	16294-824	Pin, Spring (1/4 x 1-1/2)	1
5	49003	Lever Assy (Consists of Items 1, 2, 3, 4)	1
6	16009-6	Bearing, Thrust (BUNTING TW-37)	2
7	41403	Spring	1
8	16381-13	Pin, Hitch	2
9	49010	Pin	2
10	49007	Plate, Lock	2
11	49804-3	Spacer	1
12	49804-2	Spacer	3
13	49804-1	Spacer	1
14	16236-4	Knob	1
15	49802-1	Lever Assy, Free Spool	1
16	16047-632	Cap Screw (3/8 UNC x 4)	2
17	16064-6	Washer (3/8)	2
18	16039-66	Lock Nut (3/8)	1
19	16033-6	Nut (3/8 Hex)	2
20	49314	Plate, Instruction, Powershift	1
21	53362-2	Plate, Instruction, Powershift w/Manual Brake	1
22	49807-2	Plate, Instruction, Free Spool	1
23	NSS	* Housing, Powershift w/Free Spool (Order Control Stand Assembly)	

*Refer to Control Group, pages 5 and 7 for part number of complete Control Stand Assembly.

CARCO MODEL 60-PS, PSM & PSC WINCH
 PARTS LIST SECTION—PAGE 32
 MANUAL BRAKE CONTROL STAND

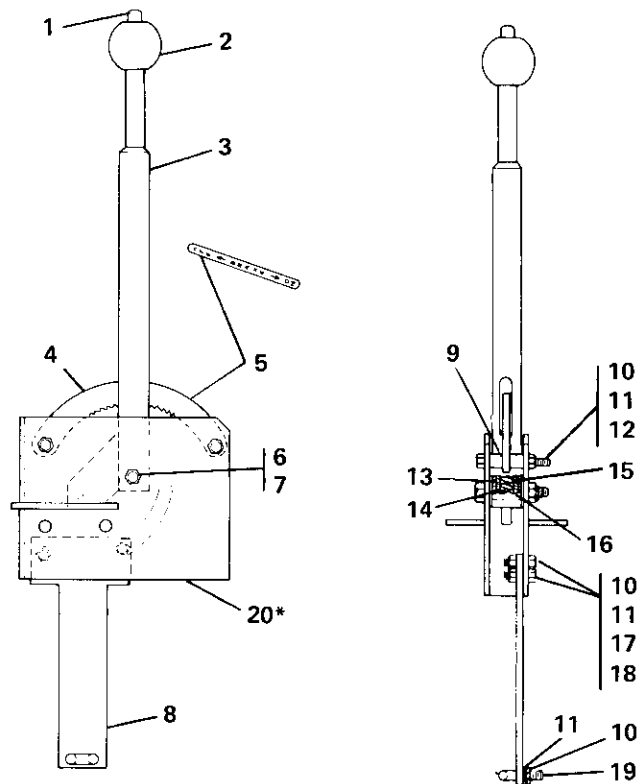

MANUAL BRAKE CONTROL STAND ASSEMBLY NO. 49434*

REF.	CARCO PART NO.	NAME AND DESCRIPTION	QUAN. PER UNIT
1	50629	Rod	1
2	41404	Ball	1
3	49435	Handle	1
4	50627	Sector	1
5	49446	Plate, Instruction	1
6	16039-83	Nut, Lock	1
7	16047-818	Cap Screw (1/2 UNC x 2-1/4)	1
8	50099	Arm	1
9	49438	Spacer	4
10	16033-6	Nut (3/8)	6
11	16067-6	Washer, Lock (3/8)	6
12	16047-620	Cap Screw (3/8 UNC x 2-1/2)	2
13	49437	Bushing	1
14	49436	Washer	2
15	49445	Spring	1
16	16064-3	Washer, Plain	1
17	16047-608	Cap Screw (3/8 UNC x 1)	2
18	16064-6	Washer, Plain	2
19	16398-4	U-Bolt (3/8)	1
20	NSS	* Housing (Order complete Control Stand Assembly)	

*Refer to Control Group, pages 6 and 7 for part number of complete Control Stand Assembly.

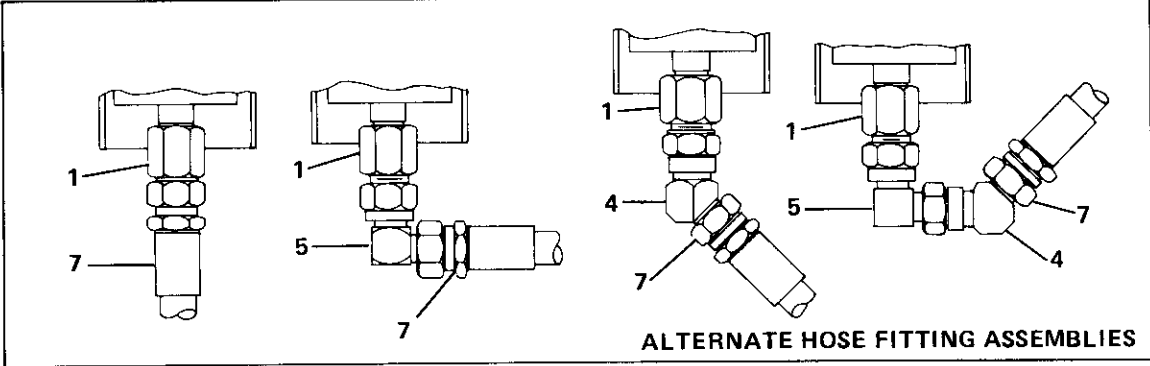
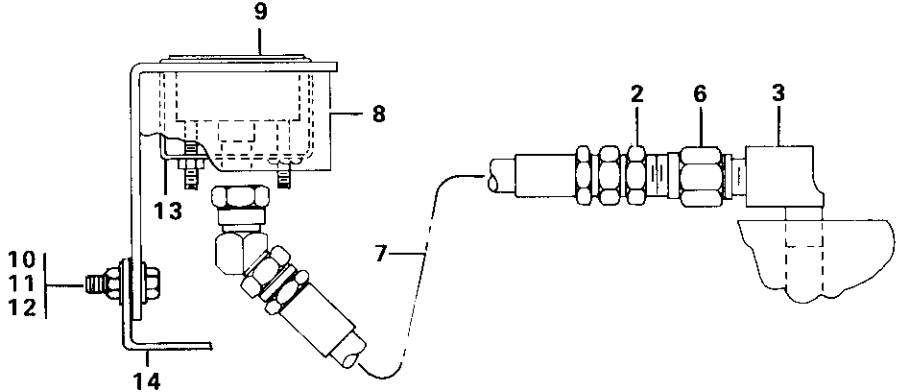

REF.	CARCO PART NO.	NAME AND DESCRIPTION	KIT NUMBER		
			48944-120	48700-120	51480-1
			QUAN. PER UNIT	QUAN. PER UNIT	QUAN. PER UNIT
1	16116-44	Adapter (WTHRD. C5255 x 4 x 4)	1	1	1
2	16129-44	* Connector (WTHRD. C5205 x 4 x 4)	1	1	1
3	16171-44	* Elbow (WTHRD. 3400 x 4)	1	1	1
4	16184-44	Union (WTHRD. C5356 x 4)	1	1	—
5	16185-44	Union (WTHRD. C5506 x 4)	1	1	—
6	16362-44	* Snubber (CHEMIQUIP 25B-D)	1	1	1
7	44921-120	Hose Assembly	1	1	1
8	48687	Bracket	1	1	—
9	48693-1	Gauge	1	1	1
10	16047-608	Screw, Hex Hd Cap (3/8 x 1 UNC)	1	—	—
11	16033-6	Nut, Hex (3/8 UNC)	1	—	—
12	16063-6	Washer (3/8)	1	—	—
13	16385	Bracket	1	1	1
14	49343-2	Bracket	1	—	—

*Items 2, 3, and 6 are also shown in hydraulic control section.

CARCO MODEL 60-PS, PSM & PSC WINCH
 PARTS LIST SECTION—PAGE 34
 FAIRLEAD

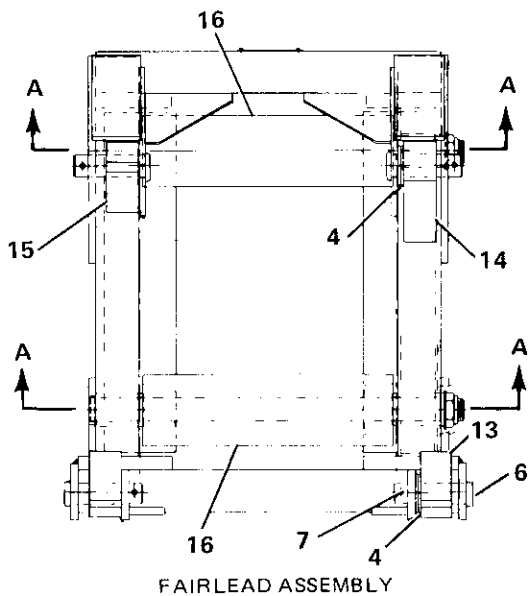

FAIRLEAD ASSEMBLY

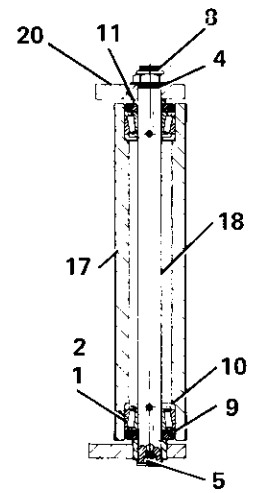
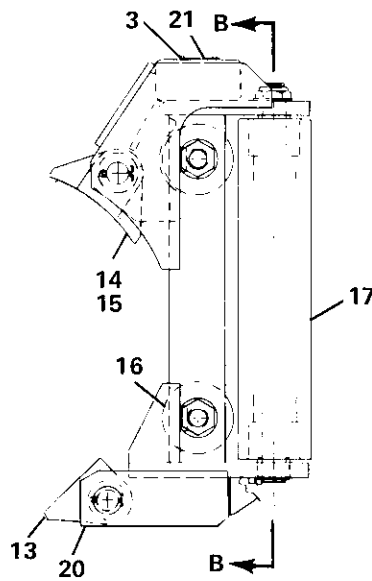

SECTION B-B
 (VERTICAL ROLLER)

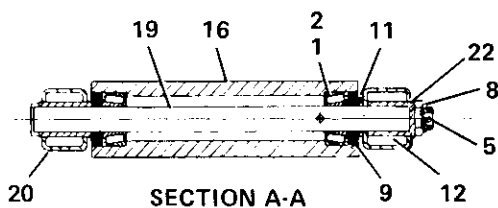

SECTION A-A
 (HORIZONTAL ROLLER)

NOTE: THIS FAIRLEAD IS NORMALLY FURNISHED AS A 3-ROLLER UNIT, WITH HORIZONTAL ROLLER IN TOP POSITION — IF A 4-ROLLER UNIT IS REQUIRED, AN ADDITIONAL ROLLER CAN BE SUPPLIED CONSISTING OF ITEMS LISTED IN COLUMN "A" IN PARTS LIST.

FAIRLEAD — PART NO. 53289-030 (3 ROLLER)
 53289-040 (4 ROLLER)

REF.	CARCO PART NO.	NAME AND DESCRIPTION	QUAN. PER UNIT	"A"
1	15178	Cone	6	2
2	15235	Cup	6	2
3	16055-5	Screw, Tapping (#10 x 3/8 Type U)	4	
4	16064-24	Washer, Plain (1-1/2)	6	
5	16222-2	Fitting, Grease (ALEMITE 1606B)	5	1
6	16287-6	Pin, Clevis (1-1/2 x 5)	4	
7	16288-832	Pin, Cotter (1/4 x 2)	4	
8	16533-24	Nut, Lock (ESNA 52NTE-242)	3	1
9	30044	Guard Assembly, Dust	6	2
10	30045	Retainer, Grease	4	
11	53281-0001	Spacer	3	1
12	53281-0002	Spacer	1	1
13	53282-1	Lug, Lower	2	
14	53282-2	Lug, Brake Side, LH	1	
15	53282-3	Lug, Gear Side, RH	1	
16	53283-0001	Roller	1	1
17	53283-0002	Roller	2	
18	53284-1	Shaft, Vert.	2	
19	53285-1	Shaft, Horiz.	1	1
20	53288	Frame	1	
21	53449	Plate, Name	1	
22	53255-01	Washer, Special	1	1

CARCO MODEL 60-PS, PSM & PSC WINCH
PARTS LIST SECTION—PAGE 35
FAIRLEAD

THIS FAIRLEAD IS NORMALLY FURNISHED AS A 3-ROLLER UNIT, WITH HORIZONTAL ROLLER IN TOP POSITION — IF A 4-ROLLER UNIT IS REQUIRED, AN ADDITIONAL ROLLER CAN BE SUPPLIED CONSISTING OF ITEMS LISTED IN COLUMN "A" IN PARTS LIST.

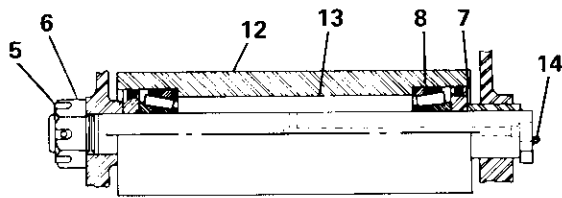
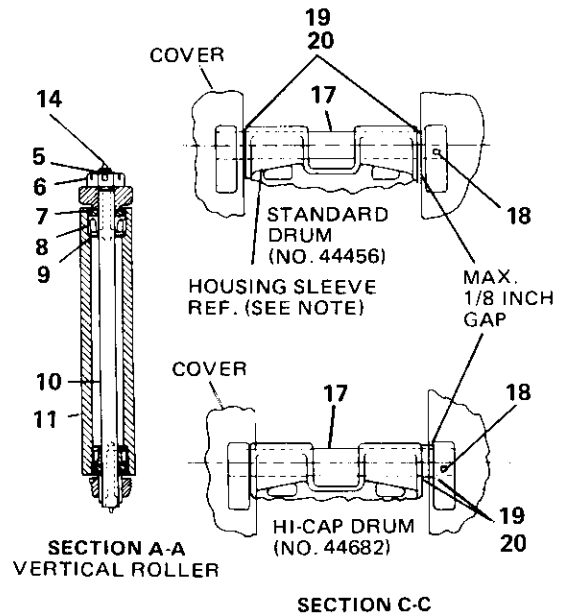
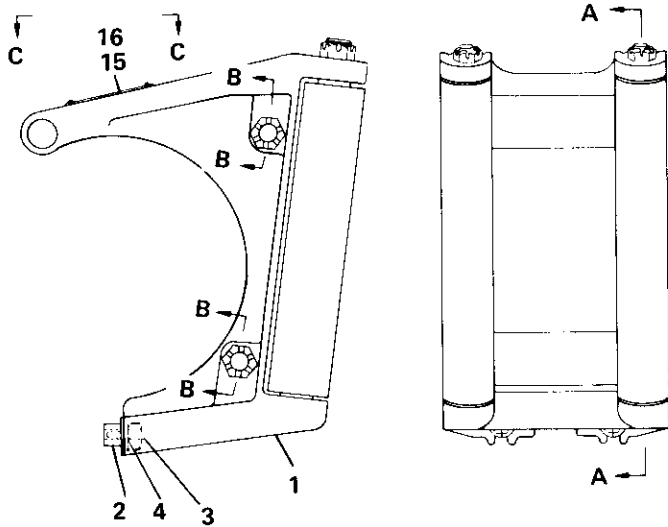

SECTION B-B
HORIZONTAL ROLLER

NOTE: AT INSTALLATION, POSITION HOUSING (ITEM 1) SO IT IS CENTERED AS NEARLY AS POSSIBLE ON CABLE DRUM. BURN END OF HOUSING SLEEVE IF NECESSARY, INSTALL ITEMS 19 AND 20 AS REQUIRED TO MAKE MAXIMUM GAP OF 1/8" BETWEEN SPACERS AND WINCH COVER.

FAIRLEAD — PART NO. 44280-30 (3 ROLLER) — 44280-40 (4 ROLLER)

REF.	CARCO PART NO.	NAME AND DESCRIPTION	QUAN. PER UNIT	"A"
1	44368	Housing	1	
2	42184	* Attaching Lug	2	
3	16047-2018	Cap Screw (1-1/4 UNC x 2-1/4 H.H.)	2	
4	16063-20	Washer	2	
5	16288-1240	Cotter Pin (3/8 x 2-1/2)	3	1
6	16036-24	Nut (TIMKEN K8111)	3	1
7	30044	Dust Guard	6	2
8	{ 15235	Bearing Cup	6	2
	{ 15178	Bearing Cone	6	2
9	30045	Retainer	4	
10	30252	Shaft	2	
11	30250	Roller	2	
12	33958	Roller	1	1
13	44371	Shaft	1	1
14	16222-2	Fitting (ALEMITE 1610B)	5	1
15	26248	Name Plate	1	
16	16055-5	Drive Screw (#10 x 3/8 Type U)	4	
17	49043-1	Cable Guard	1	
18	16288-1272	Cotter Pin (3/8 x 4-1/2)	1	
19	49879-1	Spacer	2	
20	49879-2	Spacer	2	

*Welds to Winch Case.

CARCO MODEL 60-PS, PSM & PSC WINCH
 PARTS LIST SECTION—PAGE 36
 FAIRLEAD

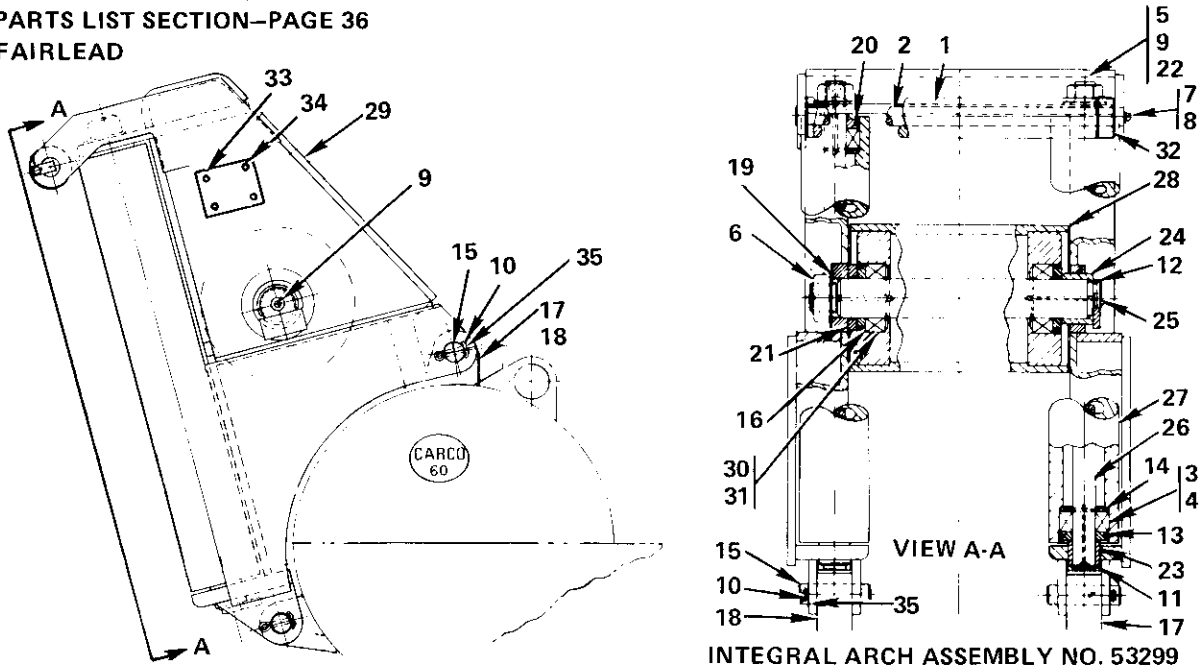

INTEGRAL ARCH ASSEMBLY NO. 53299

REF.	CARCO PART NO.	NAME AND DESCRIPTION	QUAN. PER UNIT
1	P50078	Roller w/Bushing	1
2	P50080	Shaft, Roller	1
3	15178	Cone	4
4	15235	Cup	4
5	16044-24	Nut (1-1/2 UNF Hex Jam)	2
6	16044-36	Nut (2-1/4 UNF Hex Jam)	1
7	16047-504	Cap Screw (5/16 UNC x 1/2 H.H.)	1
8	16067-5	Washer, Lock (5/16)	1
9	16222-2	Fitting, Grease (ALEMITE 16108)	6
10	16288-832	Pin, Cotter (1/4 x 2)	4
11	16311-257	Ring, Retaining (NAT'L. XSO-257 Ext.)	2
12	16311-264	Ring, Retaining (NAT'L. XSO-264 Ext.)	1
13	30044	Guard, Dust	4
14	30045	Retainer, Grease	4
15	16287-6	Pin, Clevis (LEITZKE, 1-1/2 x 4-1/4)	4
16	53294	Guard, Dust	2
17	53292-1	Lug, Gear Side, LH	3
18	53292-2	Lug, Brake Side, RH	1
19	53293-01	Washer	1
20	53293-02	Spacer	2
21	53293-03	Spacer	1
22	53293-04	Washer	2
23	53293-07	Spacer	2
24	53293-10	Spacer	1
25	53295-1	Shaft, Horizontal	1
26	53295-2	Shaft, Vertical	2
27	30705	Roller, Vertical	2
28	53297	Roller, Horizontal	1
29	53298	Frame	1
30	15325	Cup	2
31	15326	Cone	2
32	P50081	Bushing	2
33	53449	Plate, Name	1
34	16055-5	Screw (#10 x 3/8 Type U)	4
35	16064-24	Washer (1-1/2)	4

CAUTION: Mounting fasteners may change when installing arch to winch and tractor.
 Refer to winch arch mounting group page for fasteners.