

CARCO MODEL 120-PS, PSM & PSC WINCH
 MOUNTING GROUP PARTS LIST—PAGE 3
 CATERPILLAR D8K P.S. AND D.D. TRACTOR

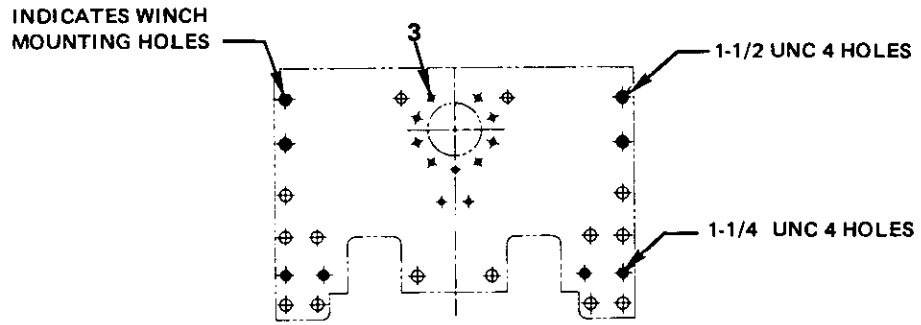

VIEW OF TRACTOR REAR FACE

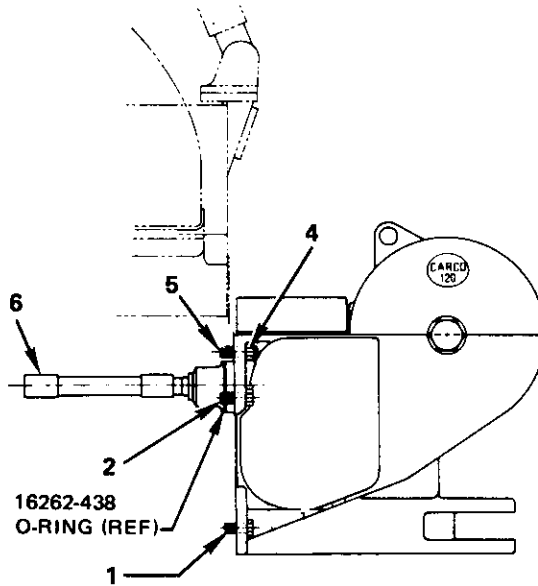

MOUNTING GROUP NO. 52293

| REF. | CARCO PART NO. | NAME AND DESCRIPTION | QUAN. PER UNIT |
|------|----------------|------------------------------------|----------------|
| 1 | 16047-2022 | Cap Screws, 1-1/4 UNC x 2-3/4 H.H. | 4 |
| 2 | 16047-2424 | Cap Screws, 1-1/2 UNC x 3 H.H. | 2 |
| 3 | 16220-6 | Closure, CAPLUG 5 x Type A | 9 |
| 4 | 16400-24 | Nut, 1-1/2 UNC Hex | 2 |
| 5 | 45050-2436 | Stud | 2 |
| * 6 | See Below | PTO Shaft Assembly | 1 |

* D8 Power Shift Tractor use PTO Shaft No. 45765-4
 D8 Direct Drive Tractor use PTO Shaft No. 45765-5

PARTS LIST SECTION
CARCO MODEL 120-PS, PSM AND PSC WINCH
WITH INTERNAL HYDRAULICS
FOR
CATERPILLAR D8K P.S. AND D.D. TRACTOR

| | Page |
|---|------------|
| BEVEL GEAR SHAFT. | 16-17 |
| BEVEL GEAR AND BEVEL PINION CARRIER ASSEMBLY (PS AND PSM) | 19 |
| BEVEL GEAR AND BEVEL PINION CARRIER ASSEMBLY (PSC) | 21 |
| BRAKE CONTROL (PS, SPRING APPLIED) | 27 |
| BRAKE CONTROL (PS, WITH 2 IN 1 INCHING BRAKE) | 28 |
| BRAKE CONTROL (PS, WITH HEAVY DUTY BRAKE ASSEMBLY) | 29 |
| BRAKE CONTROL (PSM AND PSC, MANUAL) | 30 |
| BRAKE CYLINDER | 31 |
| BRAKE SHAFT, BRAKE BAND AND LINING | 23 |
| CLUTCH | 18 |
| CONTROL GROUP (CONTROL STANDS, CONTROL CABLES, PRESSURE GAUGES) | 4, 5, 6, 7 |
| CONTROL STAND COMPONENTS (POWER SHIFT) | 33 |
| CONTROL STAND COMPONENTS (PSM AND PSC, MANUAL, INCHING BRAKE, HEAVY DUTY BRAKE) | 34-35 |
| CONTROL VALVE | 10-11 |
| DRUM SHAFT (STANDARD AND HI CAP) | 26 |
| FAIRLEAD | 36 |
| HYDRAULIC TUBING AND FITTINGS | 12-13 |
| IDLER SHAFT (STANDARD) | 24 |
| IDLER SHAFT (WITH HEAVY DUTY BRAKE ASSEMBLY) | 25 |
| MOUNTING GROUP (PTO SHAFT, STUDS, CAP SCREWS) | 3 |
| PUMP GROUP (PUMP, TUBING, FILTER) | 14-15 |
| PRESSURE GAUGE KIT COMPONENTS | 32 |
| WINCH CASE | 8-9 |

Note: Purchased parts, such as bearings and oil seals may be substituted with parts of equal quality on the manufacturer's recommendation, and with the approval of Pacific Car and Foundry Company.

ATTENTION: Be sure to give correct part number, part name and complete serial number of winch when ordering. Also name and model of the tractor on which the winch is mounted

CARCO
WINCH PRODUCTS

PACIFIC CAR AND FOUNDRY COMPANY • A DIVISION OF **PACCAR**
1400 NORTH FOURTH STREET, RENTON, WASHINGTON 98055 U.S.A.
TELEPHONE: (206) 235-2799 TELEEX 32-8942

CARCO MODEL 120-PS WINCH
 CONTROL GROUP PARTS LIST—PAGE 4
 CATERPILLAR D8K P.S. AND D.D. TRACTOR

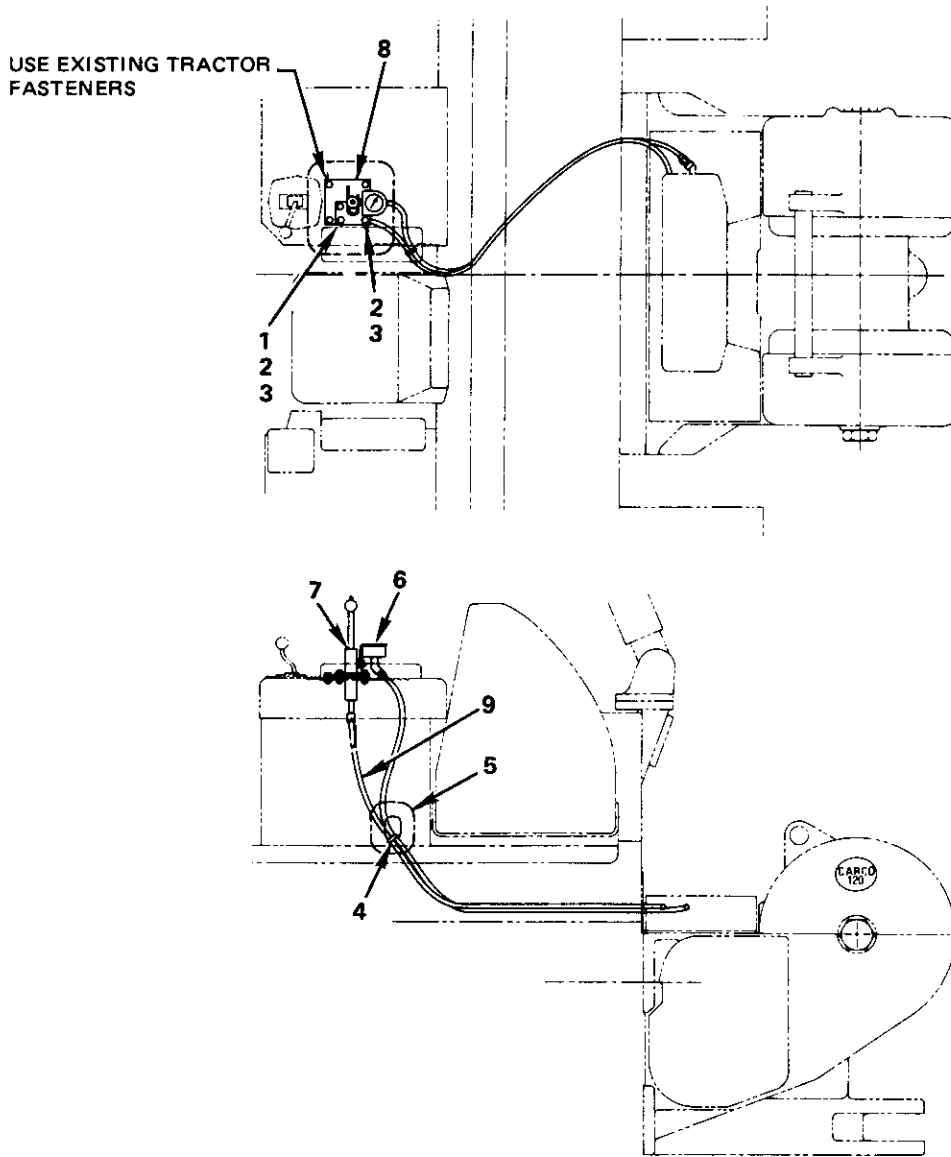

CONTROL GROUP (PS) NO. 51936

| REF. | CARCO PART NO. | NAME AND DESCRIPTION | QUAN. PER UNIT |
|------|----------------|-------------------------------|----------------|
| 1 | 16033-6 | Nut, 3/8 UNC Hex | 3 |
| 2 | 16047-608 | Cap Screw, 3/8 UNC x 1 H.H. | 4 |
| 3 | 16067-6 | Lock Washer, 3/8 | 4 |
| 4 | 16459-1 | Retng. Strap, ADEL 668-4-8-DR | 1 |
| 5 | 45418-10 | Trim | 1 |
| 6 | 48700-120 | Pressure Gauge Kit | 1 |
| 7 | 49001-3 | Control Stand, Power Shift | 1 |
| 8 | 50709 | Control Stand, Bracket | 1 |
| 9 | 52000-096 | Control Cable, Power Shift | 1 |

NOTE: See page 27 for brake control group.

CARCO MODEL 120-PSM & PSC WINCH
 CONTROL GROUP PARTS LIST—PAGE 5
 CATERPILLAR D8K P.S. AND D.D. TRACTOR

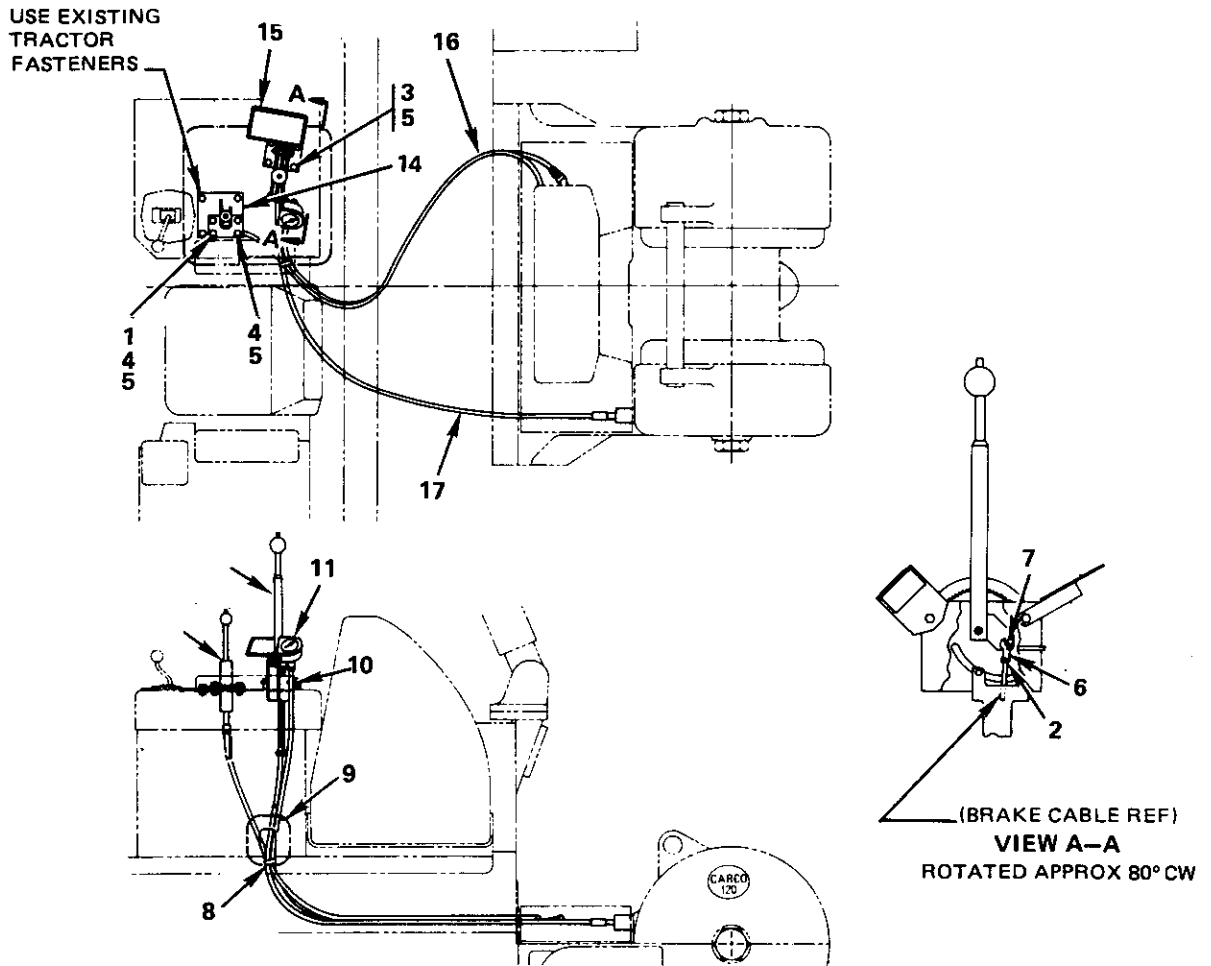

CONTROL GROUP (PS WITH 2 IN 1 INCHING BRAKE) NO. 51937

| REF. | CARCO PART NO. | NAME AND DESCRIPTION | QUAN. PER UNIT |
|------|----------------|-------------------------------------|----------------|
| 1 | 16033-6 | Nut, 3/8 UNC Hex | 3 |
| 2 | 16044-6 | Jam Nut, 3/8 UNF Hex | 1 |
| 3 | 16047-606 | Cap Screw, 3/8 UNC x 3/4 H.H. | 4 |
| 4 | 16047-608 | Cap Screw, 3/8 UNC x 1 H.H. | 4 |
| 5 | 16067-6 | Lock Washer, 3/8 | 5 |
| 6 | 16245-6 | Yoke, CLEVELAND 2708-4A | 1 |
| 7 | 16246-6 | Pin Assembly, CLEVELAND 2708-1/2-4A | 1 |
| 8 | 16459-1 | Retng. Strap, ADEL 668-4-8-DR | 1 |
| 9 | 45418-12 | Trim | 1 |
| 10 | 48290 | Tapping Pad | 4 |
| 11 | 48700-120 | Pressure Gauge Kit | 1 |
| 12 | 53598-03 | Control Stand, Power Shift | 1 |
| 13 | 49434-5 | Control Stand, Brake | 1 |
| 14 | 50709 | Control Stand, Bracket | 1 |
| 15 | 49994 | Bracket (49984 Inst Plt also Rqd) | 1 |
| 16 | 52000-096 | Control Cable, Power Shift | 1 |
| 17 | 48850-102 | Control Cable, Brake | 1 |

NOTE: See page 28 for brake control group.

**CARCO MODEL 120-PS WITH H.D. BRAKE
CONTROL GROUP PARTS LIST—PAGE 6
CATERPILLAR D8K P.S. AND D.D. TRACTOR**

USE EXISTING
TRACTOR
FASTENERS

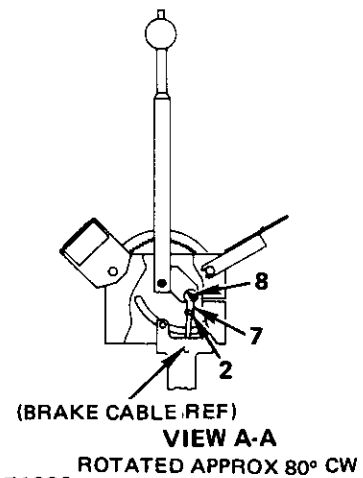
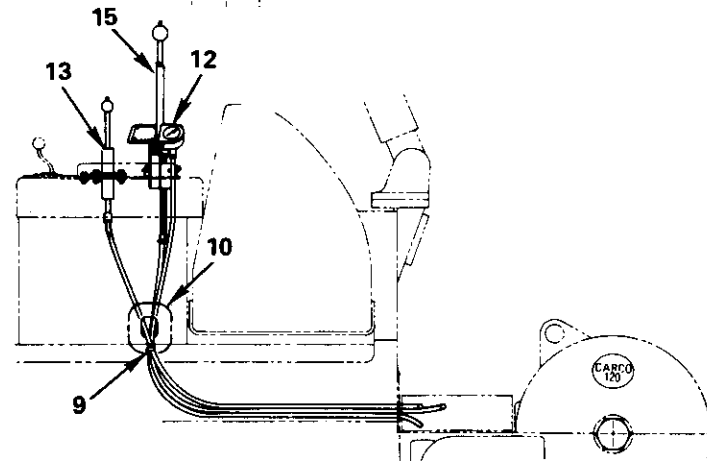
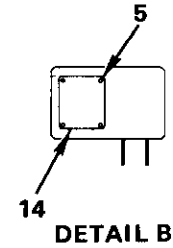
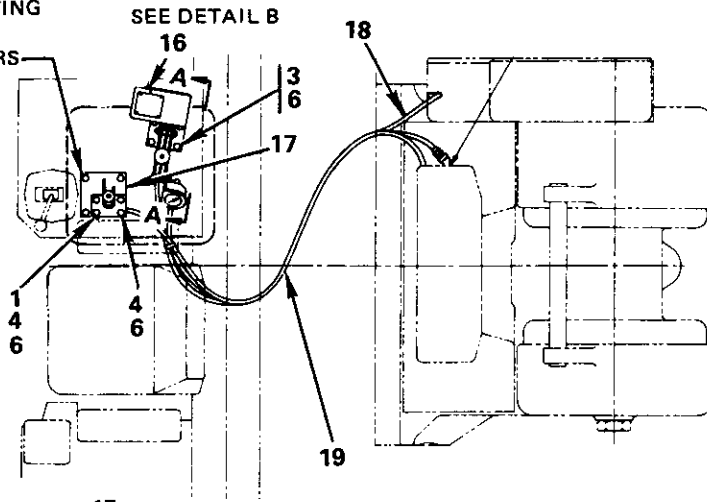

CONTROL GROUP (PS WITH HEAVY DUTY BRAKE) NO. 51939

| REF. | CARCO PART NO. | NAME AND DESCRIPTION | QUAN. PER UNIT |
|------|----------------|-------------------------------------|----------------------|
| 1 | 16033-6 | Nut, 3/8 UNC Hex | 3 |
| 2 | 16044-6 | Jam Nut, 3/8 UNF Hex | 1 |
| 3 | 16047-606 | Cap Screw, 3/8 UNC x 3/4 H.H. | 4 |
| 4 | 16047-608 | Cap Screw, 3/8 UNC x 1 H.H. | 4 |
| 5 | 16055-5 | Drive Screw, #10 x 3/8 Type U | 4 |
| 6 | 16067-6 | Lock Washer, 3/8 | 8 |
| 7 | 16245-6 | Yoke, CLEVELAND 2708-4A | 1 |
| 8 | 16246-6 | Pin Assembly, CLEVELAND 2708-1/2-4A | 1 |
| 9 | 16459-1 | Retng. Strap, ADEL 668-4-8-DR | 1 |
| 10 | 45418-12 | Trim | 1 |
| 11 | 48290 | Tapping Pad | 4 |
| 12 | 48700-120 | Pressure Gauge Kit | 1 |
| 13 | 49001-3 | Control Stand, Power Shift | 1 |
| 14 | 49073 | Instruction Plate | 1 |
| 15 | 49434-7 | Control Stand, Brake | 1 |
| 16 | 49994 | Instruction Plate Bracket | 1 |
| 17 | 50709 | Control Stand Bracket | 1 |
| 18 | 48850-114 | Control Cable, H.D. Brake | 1 |
| 19 | 52000-096 | Control Cable, Power Shift | 1 |

NOTE: See page 29 for brake control group.

CARCO MODEL 120-PSM & PSC WINCH
 CONTROL GROUP PARTS LIST--PAGE 7
 CATERPILLAR D8K P.S. AND D.D. TRACTOR

USE EXISTING TRACTOR
 FASTENERS

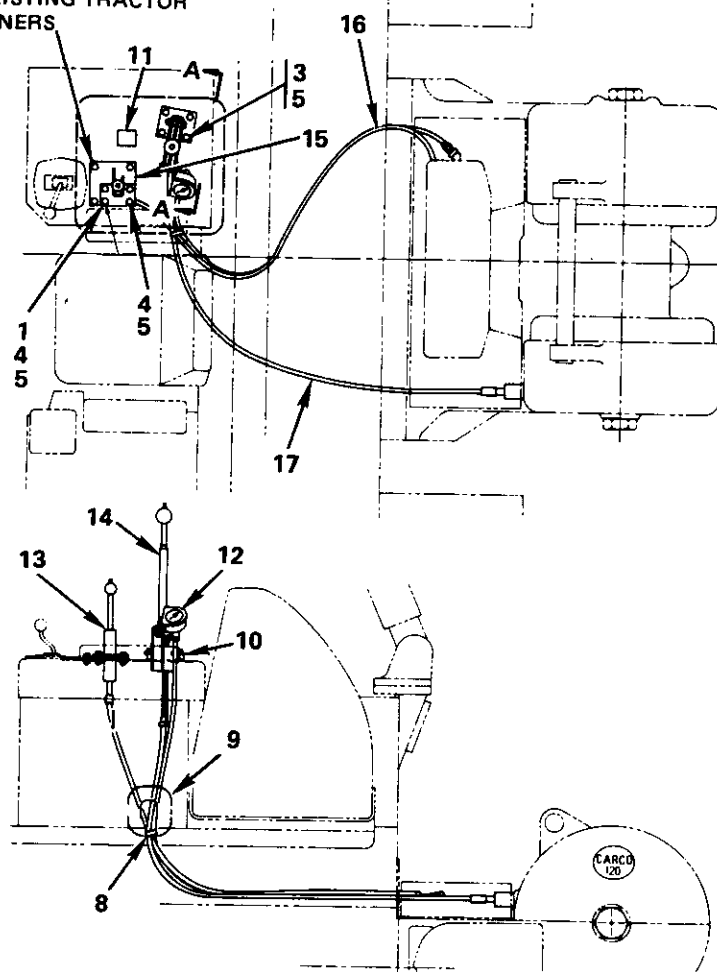

CONTROL GROUP (PSM & PSC WITH MANUAL BRAKE) NO. 51938

VIEW A-A
 ROTATED APPROX 80° CW

| REF. | CARCO PART NO. | NAME AND DESCRIPTION | QUAN. PER UNIT |
|------|----------------|-------------------------------------|----------------------|
| 1 | 16033-6 | Nut, 3/8 UNC Hex | 3 |
| 2 | 16044-6 | Jam Nut, 3/8 UNC Hex | 1 |
| 3 | 16047-606 | Cap Screw, 3/8 UNC x 3/4 H.H. | 4 |
| 4 | 16047-608 | Cap Screw, 3/8 UNC x 1 H.H. | 4 |
| 5 | 16067-6 | Lock Washer, 3/8 | 8 |
| 6 | 16245-6 | Yoke, CLEVELAND 2708-4A | 1 |
| 7 | 16246-6 | Pin Assembly, CLEVELAND 2708-1/2-4A | 1 |
| 8 | 16459-1 | Retng. Strap, ADEL 668-4-8-DR | 1 |
| 9 | 45418-12 | Trim | 1 |
| 10 | 48290 | Tapping Pad | 4 |
| 11 | 48682 | Warning Plate | 1 |
| 12 | 48700-120 | Pressure Gauge Kit | 1 |
| 13 | 53598-03 | Control Stand, Power Shift | 1 |
| 14 | 49434-7 | Control Stand, Brake | 1 |
| 15 | 50709 | Control Stand, Bracket | 1 |
| 16 | 52000-096 | Control Cable, Power Shift | 1 |
| 17 | 48850-102 | Control Cable, Brake | 1 |

NOTE: See page 30 for brake control group.

CARCO MODEL 120-PS, PSM & PSC WINCH
 PARTS LIST SECTION—PAGE 8
 WINCH CASE
 CATERPILLAR D8K P.S. AND D.D. TRACTOR

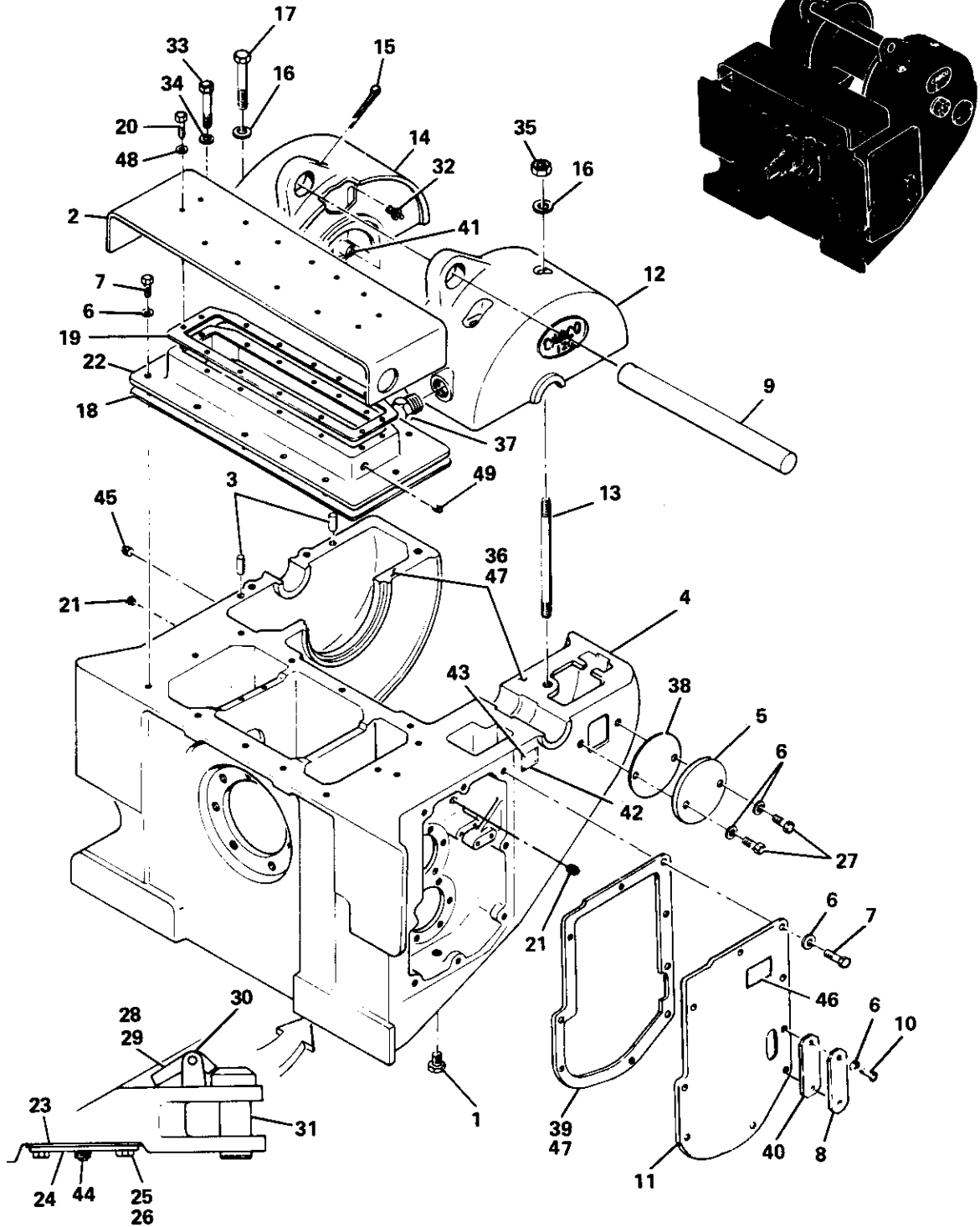

WINCH CASE

CARCO MODEL 120-PS, PSM & PSC WINCH
PARTS LIST SECTION--PAGE 9
WINCH CASE
CATERPILLAR D8K P.S. AND D.D. TRACTOR

| REF. | CARCO PART NO. | NAME AND DESCRIPTION | QUAN. PER UNIT | |
|------|----------------|---|--|---|
| 1 | 16169-8 | Plug, 1/2 NPT Sq. Hd. | 1 | |
| 2 | 51167 | Valve Housing Cover | 1 | |
| 3 | 16290-2016 | Dowel Pin, 5/8 x 1 | 2 | |
| * | 4 | 51910 | Case Complete (includes items 12 and 14) | 1 |
| 5 | 42048 | Cover | 1 | |
| 6 | 16064-10 | Washer, 5/8 | 23 | |
| 7 | 16047-1010 | Cap Screw, 5/8 UNC x 1-1/4 H.H. | 19 | |
| 8 | 44817 | Cover | 1 | |
| 9 | 49043-3 | Cable Guard (includes item 15) | 1 | |
| 10 | 16047-1012 | Cap Screw, 5/8 UNC x 1-1/2 H.H. | 2 | |
| 11 | 50654 | Brake Side Cover | 1 | |
| * | 12 | 40109 | Brake Case Cover | 1 |
| 13 | 45050-2059 | Stud | 2 | |
| * | 14 | 40108 | Gear Case Cover | 1 |
| 15 | 16288-1272 | Cotter Pin, 3/8 x 4-1/2 | 1 | |
| 16 | 16064-20 | Washer, 1-1/4 | 4 | |
| 17 | 16047-2028 | Cap Screw, 1-1/4 UNC x 3-1/2 H.H. | 2 | |
| 18 | 51146 | Gasket | 1 | |
| 19 | 51535 | Gasket | 1 | |
| 20 | 16047-608 | Cap Screw, 3/8 UNC x 1 H.H. | 14 | |
| 21 | 16167-6 | Plug, 3/8 NPT Hex Soc. | 2 | |
| 22 | Ref. Only | Housing (see page 11 item 7) | 1 | |
| 23 | 51951 | Filter Cover Gasket | 1 | |
| 24 | 51952 | Filter Cover | 1 | |
| 25 | 16047-812 | Cap Screw, 1/2 UNC x 1-1/2 H.H. | 14 | |
| 26 | 16067-8 | Lock Washer, 1/2 | 14 | |
| 27 | 16047-1008 | Cap Screw, 5/8 UNC x 1 H.H. | 2 | |
| 28 | 16246-8 | Yoke Pin Assembly, CLEVELAND 2708-1/2-6A | 1 | |
| 29 | 52085 | Latch | 1 | |
| 30 | 52084 | Support Bracket | 1 | |
| 31 | 52038 | Draw Bar Pin | 1 | |
| 32 | 16249-1 | Relief Plug, ALEMITE 317400 | 1 | |
| 33 | 16047-1424 | Cap Screw, 7/8 UNC x 3 H.H. | 4 | |
| 34 | 16064-14 | Washer, 7/8 | 4 | |
| 35 | 16033-20 | Nut, 1-1/4 UNC Hex | 2 | |
| ** | 36 | See Below | Gasket (see note below) | 1 |
| 37 | 16220-38 | Plug, WHITE 1604-136-Y | 1 | |
| 38 | 44833 | Gasket | 1 | |
| ** | 39 | See Below | Gasket (see note below) | 1 |
| 40 | 44813 | Gasket | 1 | |
| 41 | 16150-2 | Elbow, 1/8 NPT 90° Street | 1 | |
| 42 | 16055-5 | Drive Screw, *10 x 3/8 Type U | 4 | |
| 43 | 52126 | Name Plate | 1 | |
| 44 | 16168-16 | Plug, 1 NPT Mag. Sq. Hd. | 1 | |
| 45 | 16169-20 | Plug, 1/4 NPT Sq. Hd. | 1 | |
| *** | 46 | See Below | Instruction Plate | 1 |
| ** | 47 | 16453-5 | Sealant, (not shown) DOW-CORNING Silastic RTV 732, 5 oz. Tube | 1 |
| 48 | 16064-6 | Washer, 3/8 | 14 | |
| 49 | 16525-0024 | Pipe Plug, HITACHI 81-40576 Slotted Sq. Hd. | 1 | |

*Items 4, 12 and 14 cannot be ordered separately.

**Model 120 Winches do not use a gasket. Use Silastic Sealer *732RTV, item 47 or equivalent to seal items 11, 12, 14 and 39 to case.

*** 49044 Instruction Plate, PS Winches
48684 Instruction Plate, PSM, PSC & PS/1B Winches

CARCO MODEL 120-PS, PSM & PSC WINCH
 PARTS LIST SECTION—PAGE 10
 CONTROL VALVE
 CATERPILLAR D8K P.S. AND D.D. TRACTOR

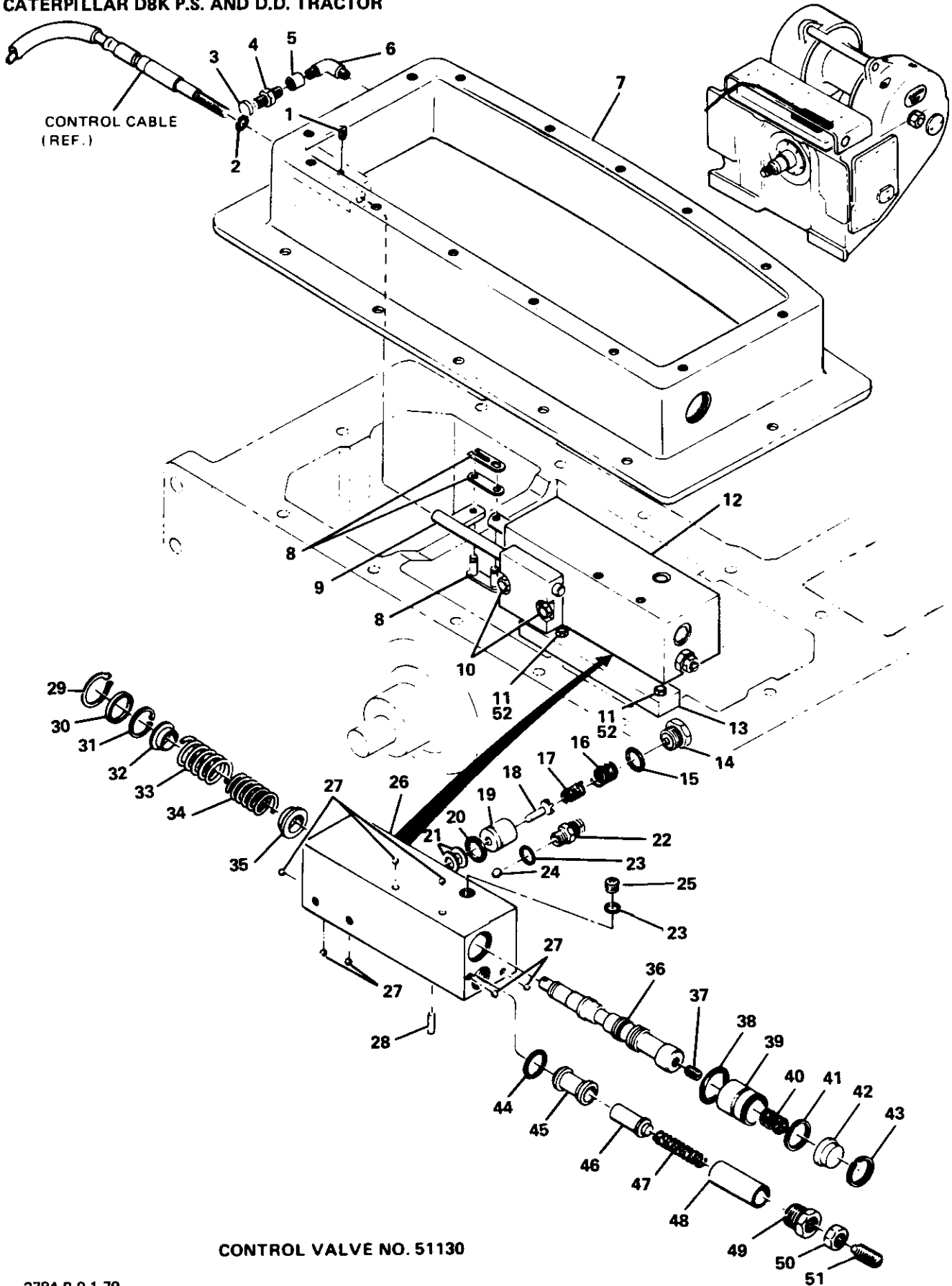

CONTROL VALVE NO. 51130

CARCO MODEL 120-PS, PSM & PSC WINCH
PARTS LIST SECTION--PAGE 11
CONTROL VALVE
CATERPILLAR D8K P.S. AND D.D. TRACTOR

| REF. | CARCO PART NO. | NAME AND DESCRIPTION | QUAN. PER UNIT |
|-------|----------------|---|----------------------|
| 1 | 16056-612 | Set Screw, 3/8 UNC x 3/4 Hex Soc. Cup Pt. | 1 |
| 2 | 16262-115 | O-Ring, NAT'L. 622713 | 1 |
| 3 | 16445-4 | Cap Nut, AEROQUIP 21029-4 | 1 |
| 4 | 16129-44 | Connector, WTHRD. C5205 x 4 x 4 | 1 |
| 5 | 16362-44 | Snubber, CHEMIQUIP 25B-D | 1 |
| 6 | 16171-44 | Elbow, WTHRD. 3400 x 4 | 1 |
| 7 | 51126-120 | Valve Housing | 1 |
| 8 | 16364-2040 | Connecting Link, ANSI 2040 | 1 |
| 9 | 51865 | Cable Guide | 1 |
| 10 | 16047-610 | Cap Screw, 3/8 UNC x 1-1/4 H.H. | 2 |
| 11 | 16047-612 | Cap Screw, 3/8 UNC x 1-1/2 H.H. | 2 |
| 12 | 51130 | Control Valve | 1 |
| 13 | 51698-2 | Support Assembly | 1 |
| 14 | 51883-1 | Retainer Assembly | 1 |
| 15 | 16262-912 | O-Ring, NAT'L. 600501 | 1 |
| 16 | 51894 | Spring | 1 |
| 17 | 52392 | Spring | 1 |
| 18 | 51164 | Accumulator Check Piston | 1 |
| 19 | 51886 | Seat | 1 |
| 20 | 16262-116 | O-Ring, NAT'L. 622714 | 1 |
| 21 | 51881-10 | Shim Set | 1 |
| 22 | 52289 | Connector (Also shown on page 13) | 1 |
| 23 | 16262-908 | O-Ring, NAT'L. 600503 (Also shown on page 13) | 2 |
| 24 | 16471-8 | Ball Check, Nylon Type 101 (Shown on page 13) | 1 |
| 25 | 16496-8 | Plug, PARKER 8HP50N-2 | 1 |
| * 26 | 51128 | Valve Body | 1 |
| 27 | 16217-8 | Steel Ball, 1/2 | 7 |
| 28 | 16290-814 | Dowel Pin, 1/4 x 7/8 | 1 |
| 29 | 16314-150 | Retaining Ring, TRUARC N5000-150 | 1 |
| 30 | 45622 | Washer | 1 |
| 31 | 16313-75 | Retaining Ring, TRUARC 5100-75 | 1 |
| 32 | 45623 | Spring Stop | 1 |
| 33 | 45549 | Outer Spring | 1 |
| 34 | 45548 | Inner Spring | 1 |
| 35 | 44259-1 | Spring Stop | 1 |
| * 36 | 51127 | Valve Spool (See note and kit No. below) | 1 |
| 37 | 16057-608 | Set Screw, 3/8 UNF x 1/2 Hex Soc. Cup Pt. | 1 |
| 38 | 16262-215 | O-Ring, NAT'L. 622720 | 1 |
| * 39 | 45855 | Piston (See note and kit No. below) | 1 |
| 40 | 45857 | Spring | 1 |
| 41 | 16308-131 | Retaining Ring, SPIROLOX RS-131 | 1 |
| 42 | 51154 | Spring Stop | 1 |
| 43 | 16305-157 | Retaining Ring, SPIROLOX RR-157 | 1 |
| 44 | 16262-210 | O-Ring, NAT'L. 622715 | 1 |
| ** 45 | 51131 | Relief Valve Seat | 1 |
| ** 46 | 51134 | Relief Valve Piston | 1 |
| 47 | 52719 | Spring, LEMPCO 9-1016-2 | 1 |
| ** 48 | 51132 | Relief Valve Tube | 1 |
| 49 | 51133 | Retaining Screw | 1 |
| 50 | 16044-12 | Jam Nut, 3/4 UNF Hex | 1 |
| 51 | 51135 | Adjusting Screw | 1 |
| 52 | 16064-6 | Washer, 3/8 | 2 |

*Items 26, 36 and 39 not serviced separately. Order 51130 Control Valve.

**Available in kit only. See No. 52652 kit below.

NOTE: To service valve spool, order repair kit No. 52651 consisting of items 24, 29, 31, 33, 34, 37, 38, 40, 41 and 43.

To service relief valve, order repair kit No. 52652 consisting of items 44, 45, 46, 47 and 48.

To service accumulator check valve, order repair kit No. 52653 consisting of items 15, 16, 17, 18, 19, 20 and 21.

CARCO MODEL 120-PS, PSM & PSC WINCH
 PARTS LIST SECTION—PAGE 12
 HYDRAULIC TUBING & FITTINGS
 CATERPILLAR D8K P.S. AND D.D. TRACTOR

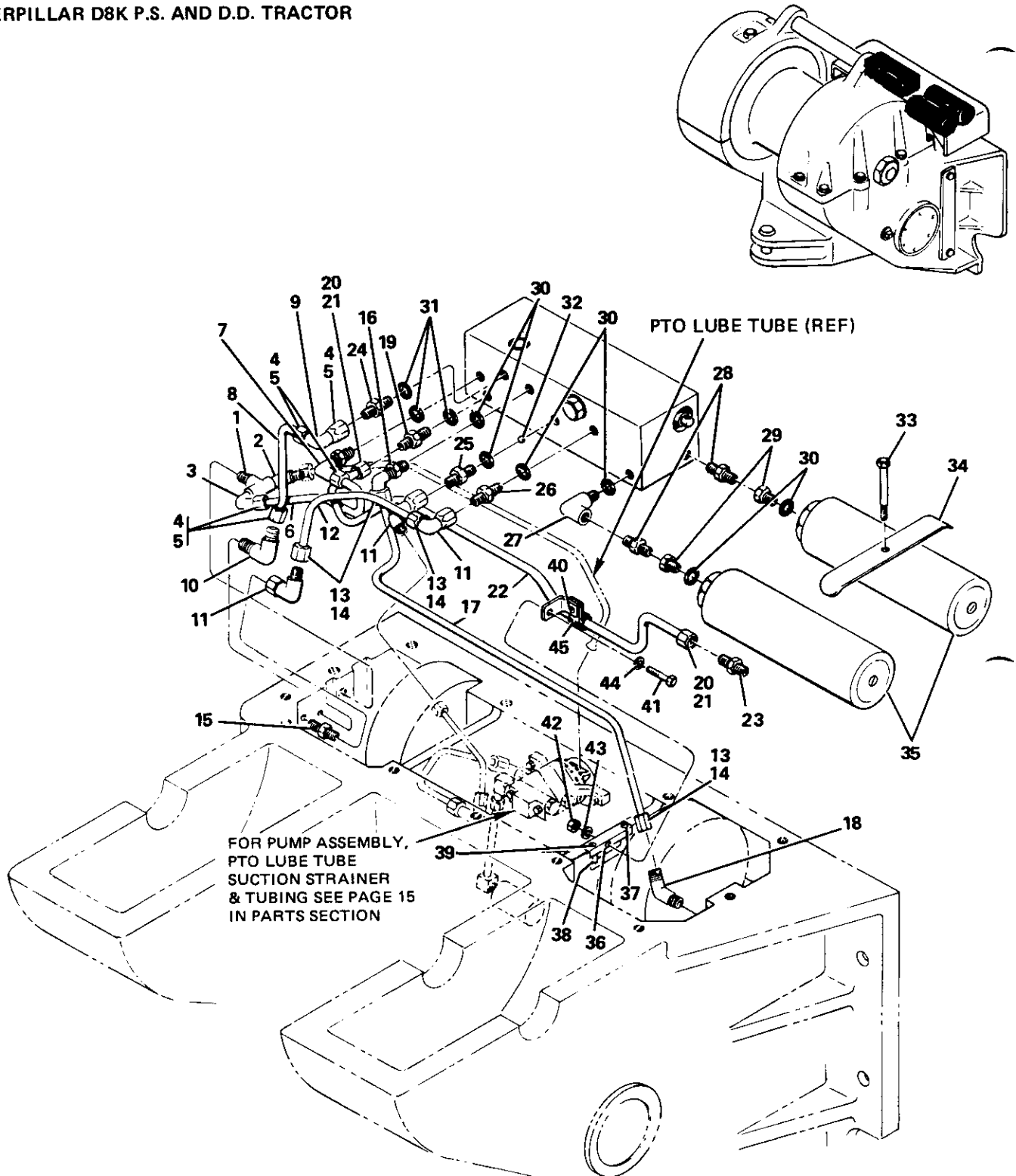

NOTE: PUMP MOUNTED ON BRAKE SIDE, NO. 51341-3.
 BEVEL GEAR INSTALLED ON GEAR SIDE OF BEVEL PINION.
 BEVEL PINION ROTATION IS C.C.W. AS VIEWED FROM REAR
 OF TRACTOR.

HYDRAULIC TUBING & FITTINGS NO. 51342

CARCO MODEL 120-PS, PSM & PSC WINCH
PARTS LIST SECTION—PAGE 13
HYDRAULIC TUBING & FITTINGS
CATERPILLAR D8K P.S. AND D.D. TRACTOR

| REF. | CARCO PART NO. | NAME AND DESCRIPTION | QUAN. PER UNIT |
|------|----------------|---|----------------------|
| 1 | 16512-0044 | Tee, PARKER 212T-4-4 | 1 |
| 2 | 16137-44 | Elbow, WTHRD. 7405 x 4 x 4 | 1 |
| 3 | 16137-0064 | Elbow, WTHRD. 7405 x 6 | 1 |
| 4 | 16521-06 | Nut, PARKER BU6 | 4 |
| 5 | 16522-06 | Sleeve, PARKER TU6 | 4 |
| 6 | 51957-06 | Brake Return Tube | 1 |
| 7 | 16476-6 | Elbow, WTHRD. 7515 x 8 | 1 |
| 8 | 51957-03 | Brake Pressure Tube | 1 |
| 9 | 16485-0006 | Elbow, WTHRD. 7506 x 6 | 1 |
| 10 | 16137-0066 | Elbow, WTHRD. 7405 x 6 x 6 | 1 |
| 11 | 16485-0008 | Elbow, WTHRD. 7506 x 8 | 3 |
| 12 | 51958-09 | Forward Clutch Tube | 1 |
| 13 | 16521-08 | Nut, PARKER BU8 | 3 |
| 14 | 16522-08 | Sleeve, PARKER TU8 | 3 |
| 15 | 16482-0086 | Connector, WTHRD. 7205 x 8 | 1 |
| 16 | 16476-8 | Elbow, WTHRD. 7515 x 8 | 1 |
| 17 | 51958-12 | Reverse Tube | 1 |
| 18 | 16478-8 | Elbow, WTHRD. 7355 x 8 | 1 |
| 19 | 16481-0046 | Connector, WTHRD. 7315 x 4 x 6 | 1 |
| 20 | 16521-04 | Nut, PARKER BU4 | 2 |
| 21 | 16522-04 | Sleeve, PARKER BU4 | 2 |
| 22 | 51956-01 | Pressure Gauge Tube | 1 |
| 23 | 16482-0044 | Connector, WTHRD. 7205 x 4 x 4 | 1 |
| 24 | 16481-0006 | Connector, WTHRD. 7315 x 6 | 1 |
| * 25 | 52289 | Connector | 1 |
| 26 | 16481-8 | Connector, WTHRD. 7315 x 8 | 1 |
| 27 | 16498-0086 | Elbow, WTHRD. C3459 x 8 | 1 |
| 28 | 16160-06 | Nipple, WTHRD. C3069 x 6 | 2 |
| 29 | 16114-0086 | Adapter, WTHRD. C3269 x 8 x 6 | 2 |
| * 30 | 16262-908 | O-Ring, NAT'L. 600503 | 6 |
| 31 | 16262-906 | O-Ring, NAT'L. 600593 | 3 |
| * 32 | 16471-8 | Ball Check, Nylon Type 101 | 1 |
| 33 | 16357-0820 | Shoulder Screw, 3/8 UNC x 2-1/2 Hex Soc. Hd | 1 |
| 34 | 51869 | Clamp | 1 |
| 35 | 16475-6 | Accumulator | 2 |
| 36 | 51868 | Plate | 1 |
| 37 | 16047-407 | Cap Screw, 1/4 UNC x 7/8 H.H. | 1 |
| 38 | 46126-407 | Spacer | 1 |
| 39 | 16047-414 | Cap Screw, 1/4 UNC x 1-3/4 H.H. | 1 |
| 40 | 16021-3 | Machine Screw, 10-24 UNC x 5/8 Rd. Hd. | 1 |
| 41 | 16021-12 | Machine Screw, 10-24 UNC x 1-1/2 Rd. Hd. | 1 |
| 42 | 16033-1024 | Nut, 10-24 UNC Hex | 1 |
| 43 | 16069-3 | Star Washer, #10 Ext. Tooth | 1 |
| 44 | 16077-3 | Washer, 3/16 | 1 |
| 45 | 16520-01 | Swivel Clamp, ADEL 1789-X4-4 | 1 |

*These items also shown with Control Valve, Page 11.

CARCO MODEL 120-PS, PSM & PSC WINCH
 PARTS LIST SECTION—PAGE 14
 PUMP GROUP
 CATERPILLAR D8K P.S. AND D.D. TRACTOR

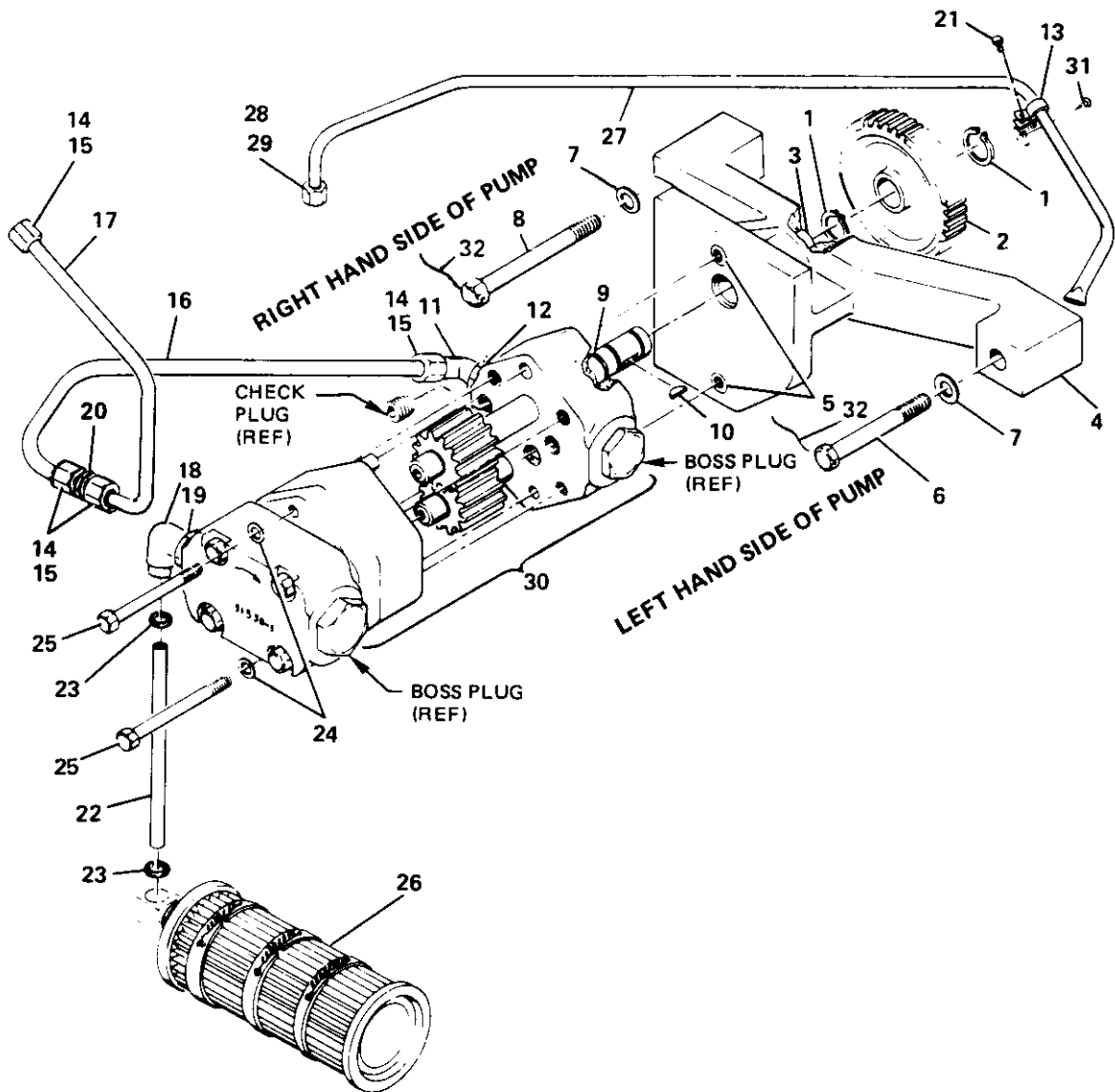

NOTE: ROTATION C.C.W. AS VIEWED FROM SHAFT END OF PUMP.
 PORT LOCATIONS, RIGHT HAND SIDE.
 CHECK PLUG AND END CAP LOCATION, RIGHT HAND SIDE.
 BEVEL GEAR INSTALLED ON GEAR SIDE OF BEVEL PINION.

PUMP GROUP NO. 51341-3

CARCO MODEL 120-PS, PSM & PSC WINCH
PARTS LIST SECTION—PAGE 15
PUMP GROUP
CATERPILLAR D8K P.S. AND D.D. TRACTOR

| REF. | CARCO PART NO. | NAME AND DESCRIPTION | QUAN. PER UNIT |
|-------|----------------|---|----------------------|
| 1 | 16313-62 | Retaining Ring, TRUARC 5100-62 | 2 |
| 2 | 51056 | Gear | 1 |
| 3 | 15305 | Needle Bearing | 1 |
| * 4 | 51525-1 | Mount Assembly (Includes Items 3 and 5) | 1 |
| 5 | 16507-0003 | Threaded Insert | 2 |
| 6 | 16024-15 | Cap Screw, 3/8 UNC x 1-3/4 Dr. Hd. | 1 |
| 7 | 16348-1 | Washer, CARR LANE CL-1-FW | 2 |
| 8 | 16024-16 | Cap Screw, 3/8 UNC x 2-1/4 Dr. Hd. | 1 |
| 9 | 16284-95 | Pump Shaft Seal, WEBSTER 151-35818 | 1 |
| 10 | 16226-7 | Key, WOODRUFF No. 3, 1/8 x 1/2 | 1 |
| 11 | 16476-8 | Elbow, WTHRD. 7515 x 8 | 1 |
| 12 | 16262-908 | O-Ring, NAT'L. 600503 | 1 |
| 13 | 16520-01 | Swivel Clamp, ADEL 1789-X4-4 | 1 |
| 14 | 16521-8 | Nut, PARKER BU8 | 4 |
| 15 | 16522-8 | Sleeve, PARKER TU8 | 4 |
| 16 | 51958-15 | Pump Tube | 1 |
| 17 | 51958-06 | Pressure Tube | 1 |
| 18 | 16474-12 | Elbow, LENZ A-405-12 | 1 |
| 19 | 16262-912 | O-Ring, NAT'L. 600501 | 1 |
| 20 | 16511-08 | Union, WTHRD. 7305 x 8 | 1 |
| 21 | 16021-3 | Screw, 10-24 UNC x 5/8 Rd. Hd. | 1 |
| 22 | 51959-56 | Suction Tube | 1 |
| 23 | 16262-116 | O-Ring, NAT'L. 622714 | 2 |
| 24 | 16069-4 | Lock Washer, 1/4 Ext. Tooth | 2 |
| 25 | 16047-428 | Cap Screw, 1/4 UNC x 3-1/2 H.H. | 2 |
| 26 | 16473 | Filter, MARVEL 620-5-M-200 | 1 |
| 27 | 51956-11 | PTO Lube Tube | 1 |
| 28 | 16521-4 | Nut, PARKER BU4 | 1 |
| 29 | 16522-4 | Sleeve, PARKER TU4 | 1 |
| ** 30 | 81771 | Pump (See Below) | 1 |
| 31 | 16055-12 | Tapping Screw, 1/4 x 3/4 Type F Fl. Hd. | 1 |
| 32 | 48125-2 | Wire, 16 Ga. x 18" | 1 |

*Item 4 is part of 51529-3 pump assembly.

**No pump parts other than items 9 and 10 are serviceable items.

CARCO MODEL 120-PS, PSM & PSC WINCH
 PARTS LIST SECTION—PAGE 16
 BEVEL GEAR SHAFT
 CATERPILLAR D8K P.S. AND D.D. TRACTOR

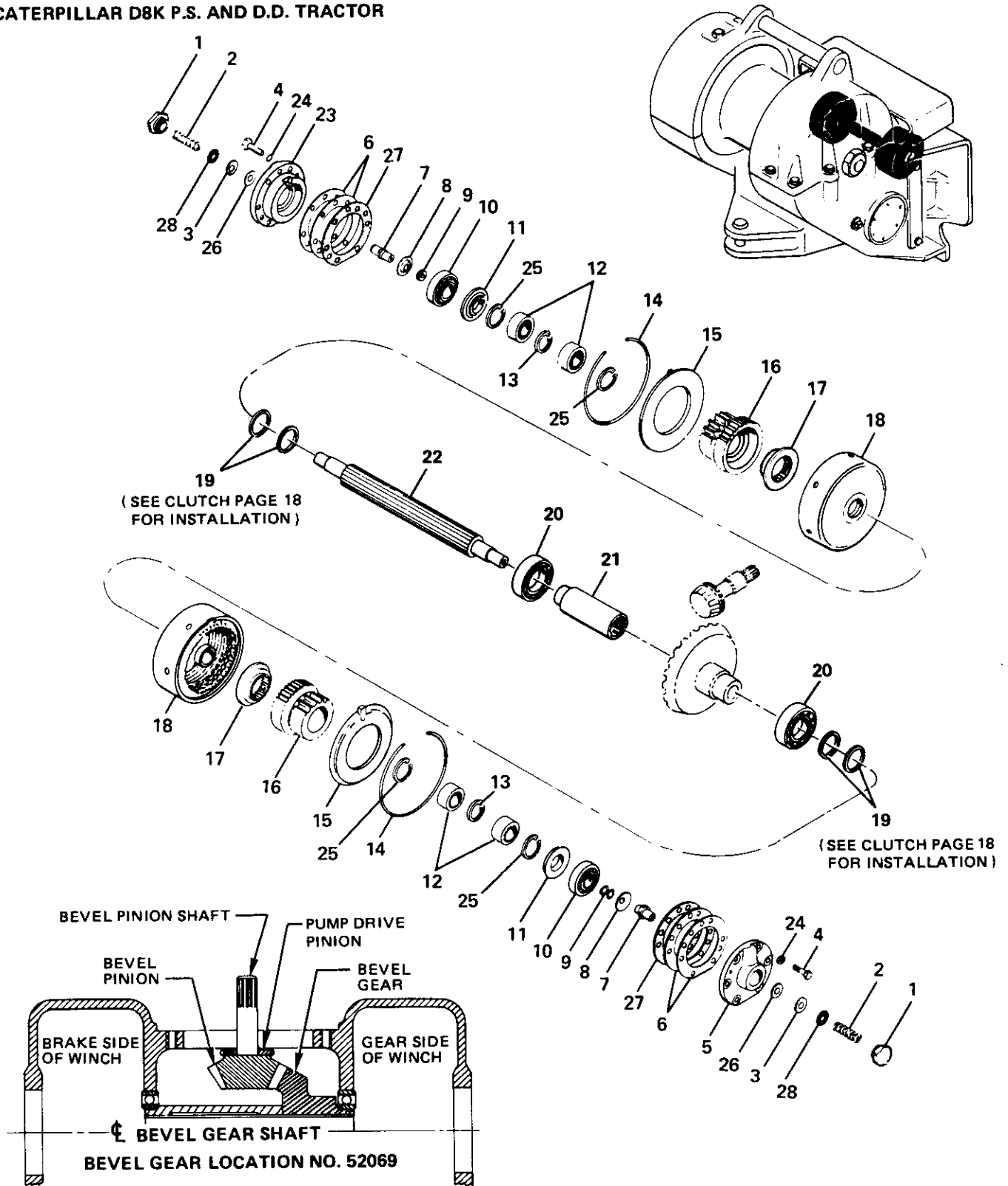

BEVEL GEAR SHAFT GROUP NO. 52273

CARCO MODEL 120- PS, PSM & PSC WINCH
PARTS LIST SECTION—PAGE 17
BEVEL GEAR SHAFT
CATERPILLAR D8K P.S. AND D.D. TRACTOR

| REF. | CARCO PART NO. | NAME AND DESCRIPTION | QUAN. PER UNIT |
|------|----------------|--|----------------------|
| 1 | 16166-20 | Plug, PARKER 05P0-20 | 2 |
| 2 | 44753 | Spring | 2 |
| 3 | 44949 | Seal (includes item 28) | 2 |
| 4 | 16047-1014 | Cap Screw, 5/8 UNC x 1-3/4 H.H. | 12 |
| 5 | 41847 | Retainer | 1 |
| 6 | 40149 | Shim Set | 2 |
| 7 | 53221 | Stub Shaft | 2 |
| 8 | 44105 | Clamp Ring | 2 |
| 9 | 44336 | Shim Set | 2 |
| 10 | 15150 | Bearing Cup | 2 |
| | 15151 | Cone | 2 |
| 11 | 44104 | Spacer | 2 |
| 12 | 15255 | Bearing Set (Matched) | 2 |
| 13 | 16314-315 | Retaining Ring, TRUARC N5000-315 | 2 |
| 14 | 49378 | Retaining Ring | 2 |
| 15 | 44083 | Retaining Ring | 2 |
| 16 | 48841 | Pinion | 2 |
| 17 | 44103 | Spacer | 2 |
| 18 | 51275-1 | Clutch (See Page 18 For Clutch Parts, Includes Items 14 & 15) | 2 |
| 19 | 40116 | Seal | 4 |
| 20 | 15044 | Ball Bearing | 2 |
| 21 | 40186 | Spacer | 1 |
| 22 | 53627 | Shaft | 1 |
| 23 | 41848 | Retainer | 1 |
| 24 | 16064-10 | Washer, 5/8 | 12 |
| 25 | 16314-350 | Retaining Ring, TRUARC N5000-350 | 4 |
| 26 | 44940 | Washer | 2 |
| 27 | 45029 | Gasket | 2 |
| 28 | 16262-121 | O-Ring, NAT'L. 610067 | 2 |

CARCO MODEL 120-PS, PSM & PSC WINCH
 PARTS LIST SECTION—PAGE 18
 CLUTCH
 CATERPILLAR D8K P.S. AND D.D. TRACTOR

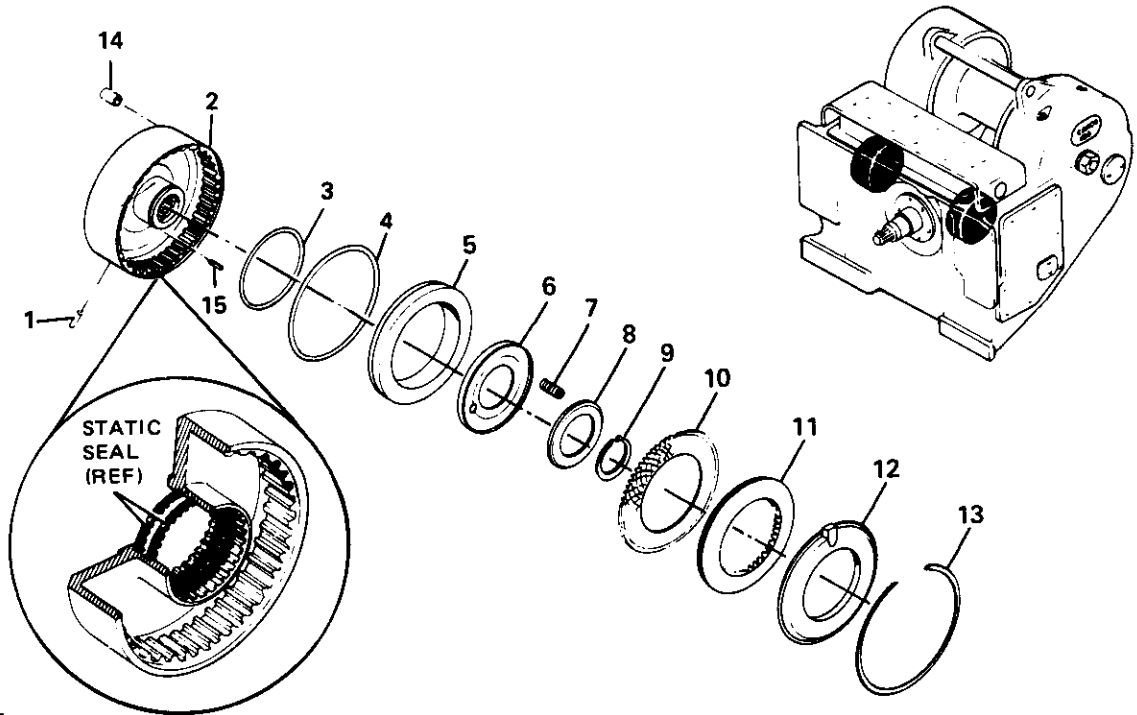

NOTE:
 ALL RELATED CLUTCH PARTS
 NOT SHOWN MUST BE ORDERED
 FROM PAGE 17.

CLUTCH NO. 51275-1

| REF. | CARCO PART NO. | NAME AND DESCRIPTION | QUAN. PER UNIT |
|------|----------------|-----------------------------------|----------------|
| 1 | 16290-1010 | Dowel Pin, 5/16 x 5/8 | 1 |
| 2 | 51274-1 | Housing (includes items 1 and 14) | 1 |
| 3 | 46246 | Seal | 1 |
| 4 | 46247 | Seal | 1 |
| 5 | 41366 | Piston | 1 |
| 6 | 40163 | Ring | 1 |
| 7 | 40128 | Spring | 17 |
| 8 | 40136 | Retainer | 1 |
| 9 | 16313-400 | Retaining Ring, TRUARC 51000-400 | 1 |
| 10 | 46129 | Friction Disc | 5 |
| 11 | 46130 | Steel Disc | 4 |
| 12 | 44083 | Retaining Ring | 1 |
| 13 | 49378 | Retaining Ring | 1 |
| 14 | 52592 | Seat Assembly | 1 |
| 15 | 16295-1428 | Pin, SPIROL 437-1750-H-B-K | 1 |

PS & PSM BEVEL GEAR AND BEVEL PINION CARRIER ASSEMBLIES

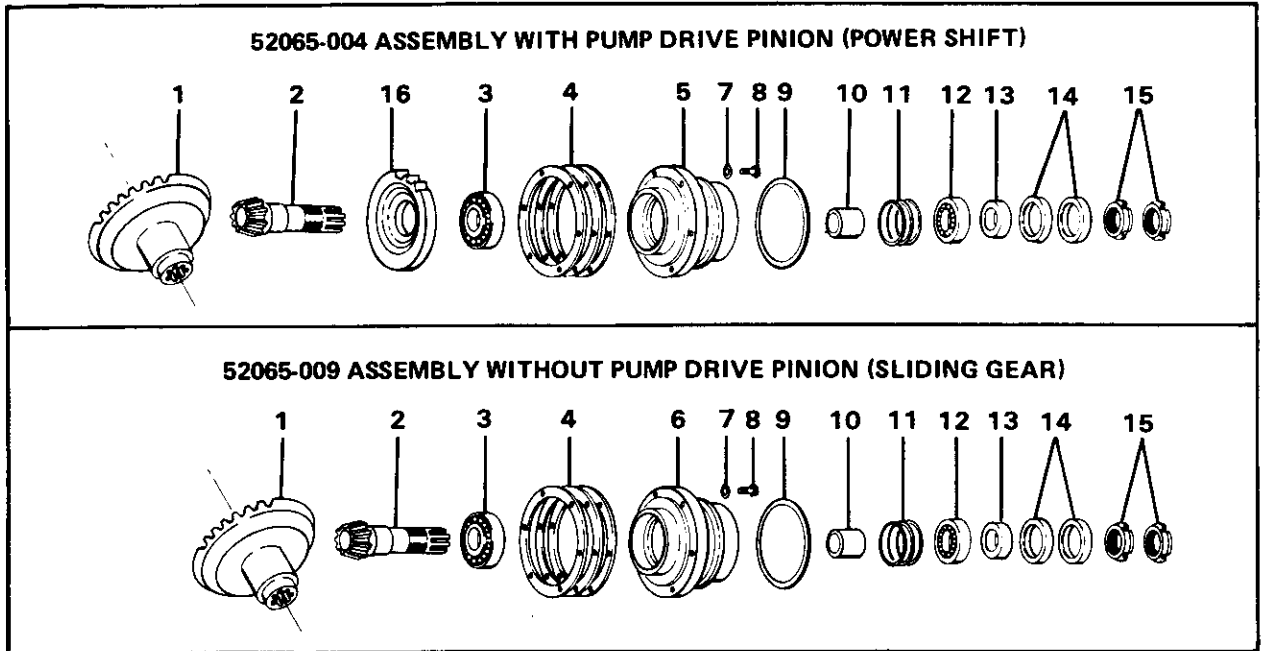

GEAR SET NO. 52065-104 RATIO 1.56/1

| REF. | CARCO PART NO. | NAME AND DESCRIPTION | 52065-004 QUAN. PER UNIT | 52065-009 QUAN. PER UNIT |
|------|----------------|---------------------------------|--------------------------------|--------------------------------|
| 1 | 51631 | Bevel Gear (42 Teeth) | 1 | 1 |
| 2 | 51630 | Bevel Pinion (27 Teeth) | 1 | 1 |
| 3 | { 15161 | Tapered Roller Bearing Cup | 1 | 1 |
| | { 15162 | Tapered Roller Bearing Cone | 1 | 1 |
| 4 | 41424 | Shim Set | 1 | 1 |
| 5 | 52666 | Carrier (P.S. Winch) | 1 | Not Used |
| 6 | 41359 | Carrier (S.G. Winch) | Not Used | 1 |
| 7 | 16064-10 | Washer, 5/8 | 6 | 6 |
| 8 | 16047-1010 | Cap Screw, 5/8 UNC x 1-1/4 H.H. | 6 | 6 |
| 9 | 16262-438 | O-Ring, NAT'L. 622765 | 1 | 1 |
| 10 | 45090-5 | Spacer | 1 | 1 |
| 11 | 45091 | Shim Set | 1 | 1 |
| 12 | { 15176 | Tapered Roller Bearing Cup | 1 | 1 |
| | { 15177 | Tapered Roller Bearing Cone | 1 | 1 |
| 13 | 40154 | Sleeve | 1 | 1 |
| 14 | 16343-18 | Oil Seal, NAT'L. 455165 | 2 | 2 |
| 15 | 45801 | Lock Nut | 2 | 2 |
| 16 | 51384 | Pump Drive Pinion | 1 | Not Used |

NOTE: The Bevel Gear Set above is standard for the adaption indicated. Below are optional gear combinations to provide a range of line speeds and pulls for various winching requirements. Important – Prior to ordering or quoting on any optional Bevel Gear Set be sure to check with factory on availability, and if the gear set would be recommended for the application.

| GEAR SET NO. | BEVEL GEAR | | BEVEL PINION | | RATIO |
|--------------|------------|-------|--------------|-------|--------|
| | Part No. | Teeth | Part No. | Teeth | |
| 52065-101 | 51622 | 44 | 51621 | 17 | 2.59/1 |
| 52065-102 | 51625 | 44 | 51624 | 22 | 2.00/1 |
| 52065-103 | 51628 | 44 | 51627 | 25 | 1.76/1 |
| 52065-105 | 51634 | 38 | 51633 | 32 | 1.19/1 |

PSC BEVEL GEAR AND BEVEL PINION CARRIER ASSEMBLIES

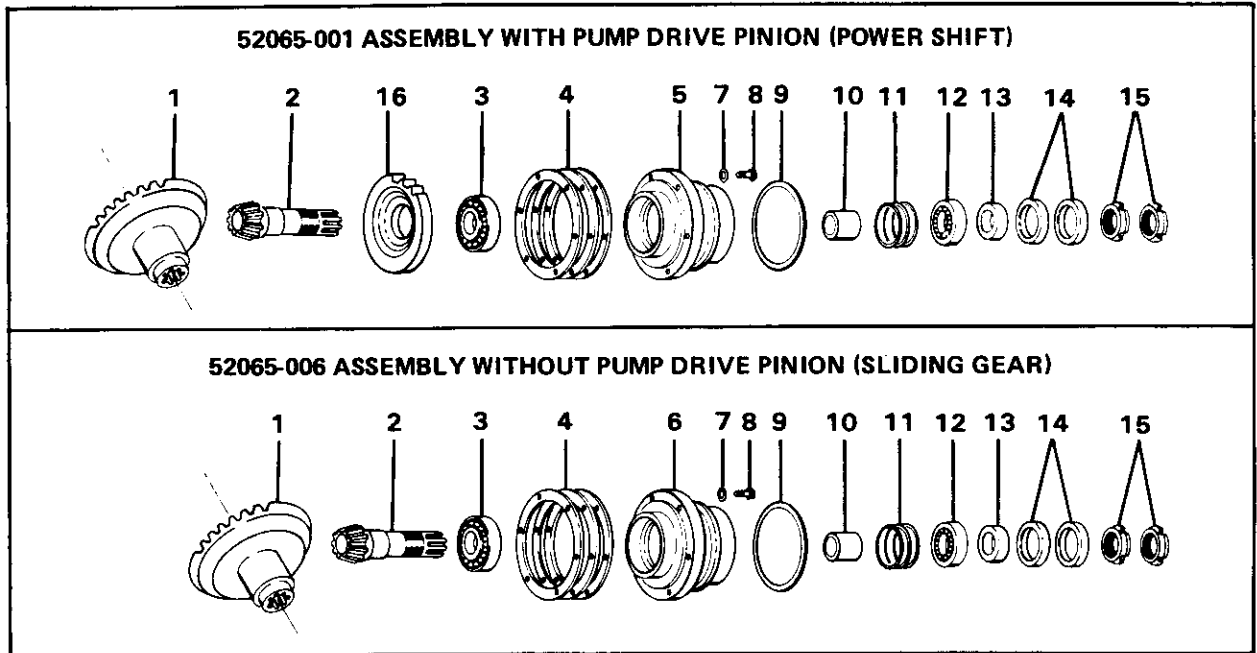

GEAR SET NO. 52065-101 RATIO 2.59/1

| REF. | CARCO PART NO. | NAME AND DESCRIPTION | 52065-001 QUAN. PER UNIT | 52065-006 QUAN. PER UNIT |
|------|----------------|---------------------------------|--------------------------------|--------------------------------|
| 1 | 51622 | Bevel Gear (44 Teeth) | 1 | 1 |
| 2 | 51621 | Bevel Pinion (17 Teeth) | 1 | 1 |
| 3 | { 15161 | Tapered Roller Bearing Cup | 1 | 1 |
| | { 15162 | Tapered Roller Bearing Cone | 1 | 1 |
| 4 | 41424 | Shim Set | 1 | 1 |
| 5 | 52666 | Carrier (P.S. Winch) | 1 | Not Used |
| 6 | 41359 | Carrier (S.G. Winch) | Not Used | 1 |
| 7 | 16064-10 | Washer, 5/8 | 6 | 6 |
| 8 | 16047-1010 | Cap Screw, 5/8 UNC x 1-1/4 H.H. | 6 | 6 |
| 9 | 16262-438 | O-Ring, NAT'L. 622765 | 1 | 1 |
| 10 | 45090-5 | Spacer — | 1 | 1 |
| 11 | 45091 | Shim Set | 1 | 1 |
| 12 | { 15176 | Tapered Roller Bearing Cup | 1 | 1 |
| | { 15177 | Tapered Roller Bearing Cone | 1 | 1 |
| 13 | 40154 | Sleeve | 1 | 1 |
| 14 | 16343-18 | Oil Seal, NAT'L. 455165 | 2 | 2 |
| 15 | 45801 | Lock Nut | 2 | 2 |
| 16 | 51384 | Pump Drive Pinion | 1 | Not Used |

NOTE: The Bevel Gear Set above is standard for the adaption indicated. Below are optional gear combinations to provide a range of line speeds and pulls for various winching requirements. Important — Prior to ordering or quoting on any optional Bevel Gear Set be sure to check with factory on availability, and if the gear set would be recommended for the application.

| GEAR SET NO. | BEVEL GEAR | | BEVEL PINION | | RATIO |
|-----------------|------------|-------|--------------|-------|--------|
| | Part No. | Teeth | Part No. | Teeth | |
| 52065-102 | 51625 | 44 | 51624 | 22 | 2.00/1 |
| 52065-103 | 51628 | 44 | 51627 | 25 | 1.76/1 |
| 52065-104 | 51631 | 42 | 51630 | 27 | 1.56/1 |
| 52065-105 | 51634 | 38 | 51633 | 32 | 1.19/1 |

CARCO MODEL 120-PS, PSM & PSC WINCH
 PARTS LIST SECTION—PAGE 23
 BRAKE SHAFT ASSEMBLY

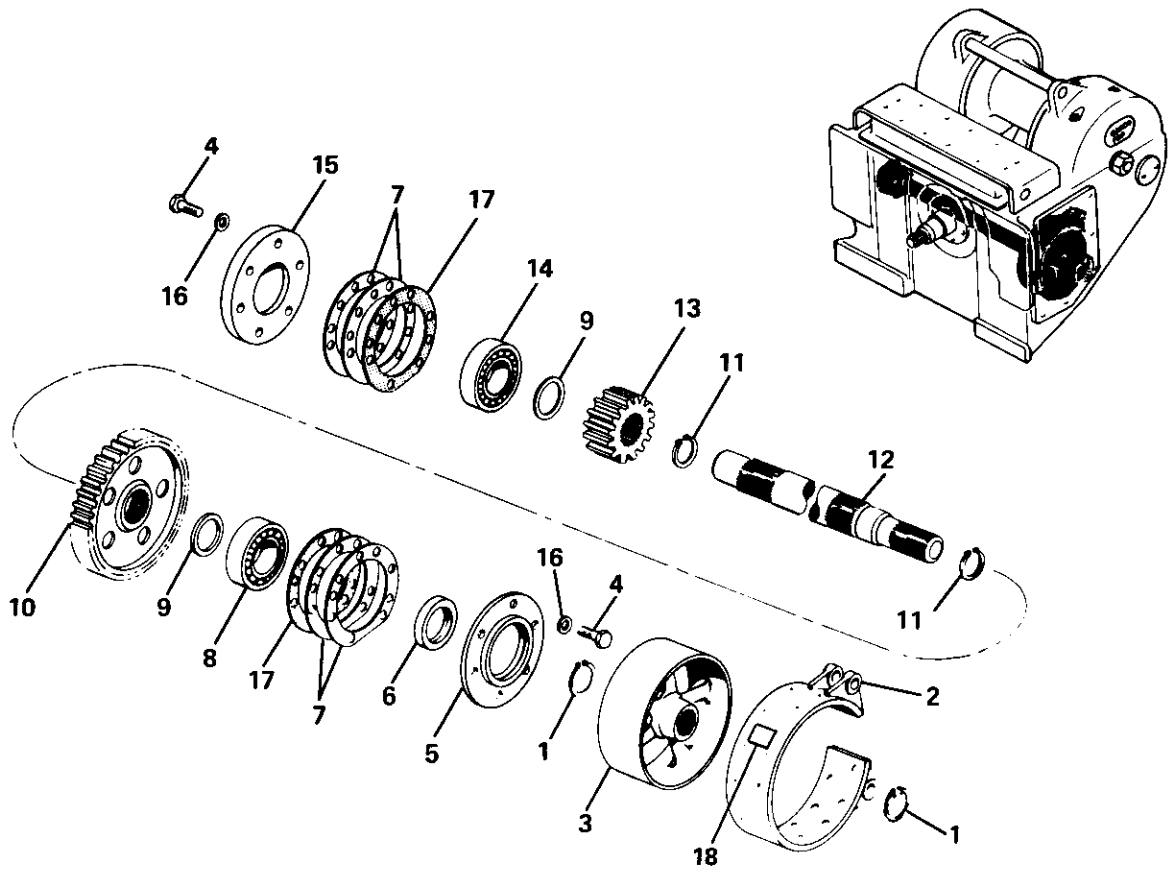

BRAKE SHAFT GROUP NO. 52277

| REF. | CARCO PART NO. | NAME AND DESCRIPTION | QUAN. PER UNIT |
|------|----------------|--|----------------|
| 1 | 16313-262 | Retaining Ring, TRUARC 5100-262 | 2 |
| 2 | 46606 | Brake Band Assembly (includes following) | 1 |
| | 46607 | Brake Block | 3 |
| | 16323-808 | Rivet, 1/4 x 1/2 Tub. Brass | 38 |
| 3 | 41358 | Brake Drum | 1 |
| 4 | 16047-1014 | Cap Screw, 5/8 UNC x 1-3/4 H.H. | 12 |
| 5 | 40138 | Carrier | 1 |
| 6 | 16342-4 | Oil Seal, NAT'L. 415004 | 1 |
| 7 | 40149 | Shim Set | 2 |
| 8 | 15145 | Ball Bearing | 1 |
| 9 | 40132 | Spacer | 2 |
| 10 | 41363 | Gear | 1 |
| 11 | 16313-300 | Retaining Ring, TRUARC 5100 x 300 | 2 |
| 12 | 41352 | Shaft | 1 |
| 13 | 41353 | Pinion | 1 |
| 14 | 15280 | Ball Bearing | 1 |
| 15 | 40150 | Cover | 1 |
| 16 | 16064-10 | Washer, 5/8 | 12 |
| 17 | 45029 | Gasket | 2 |
| 18 | 51955 | Asbestos Warning Plate | 1 |

CARCO MODEL 120-PS, PSM & PSC WINCH
 PARTS LIST SECTION—PAGE 24
 IDLER SHAFT

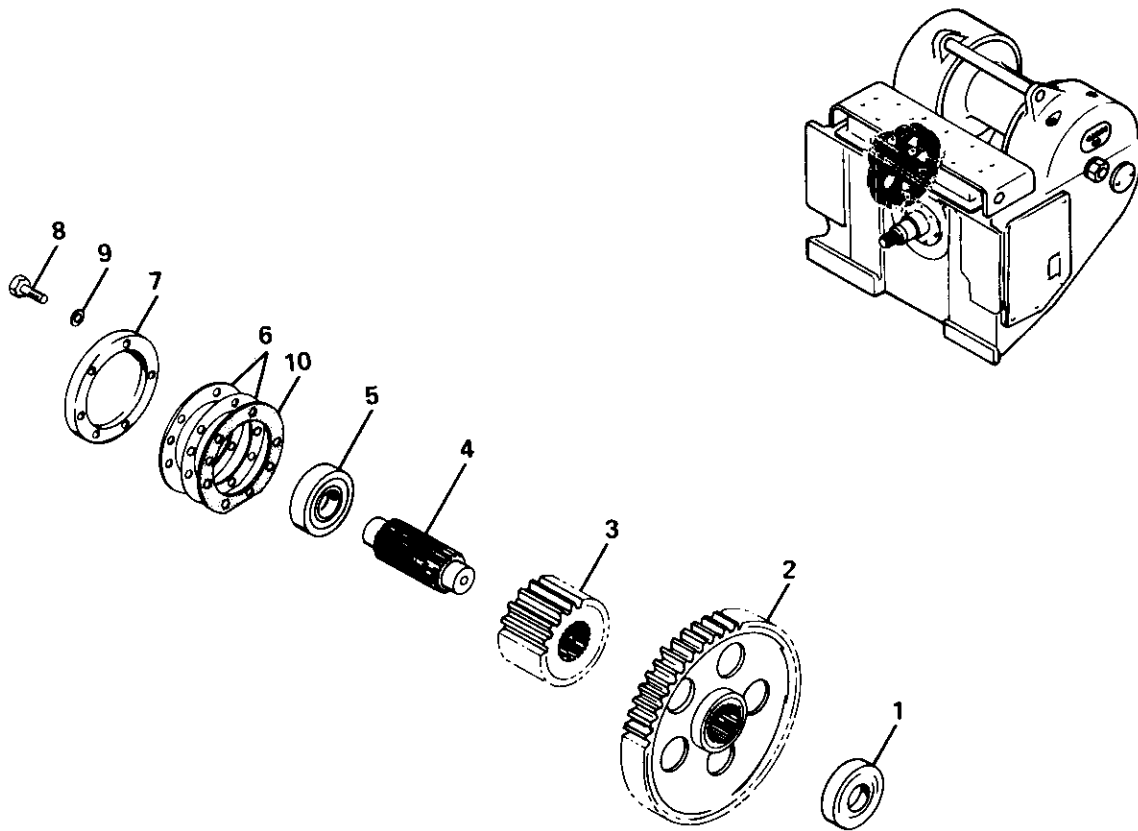

IDLER SHAFT (STANDARD) GROUP NO. 52268

| REF. | CARCO PART NO. | NAME AND DESCRIPTION | QUAN. PER UNIT |
|------|----------------|---------------------------------|----------------------|
| 1 | 15280 | Ball Bearing | 1 |
| 2 | 44882 | Gear | 1 |
| 3 | 40947 | Pinion | 1 |
| 4 | 40167 | Shaft | 1 |
| 5 | 15281 | Ball Bearing | 1 |
| 6 | 40147 | Shim Set | 1 |
| 7 | 40151 | Cover | 1 |
| 8 | 16047-1014 | Cap Screw, 5/8 UNC x 1-3/4 H.H. | 6 |
| 9 | 16064-10 | Washer, 5/8 | 6 |
| 10 | 46232 | Gasket | 1 |

CARCO MODEL 120-PSC WINCH
PARTS LIST SECTION—PAGE 25
IDLER SHAFT ASSEMBLY

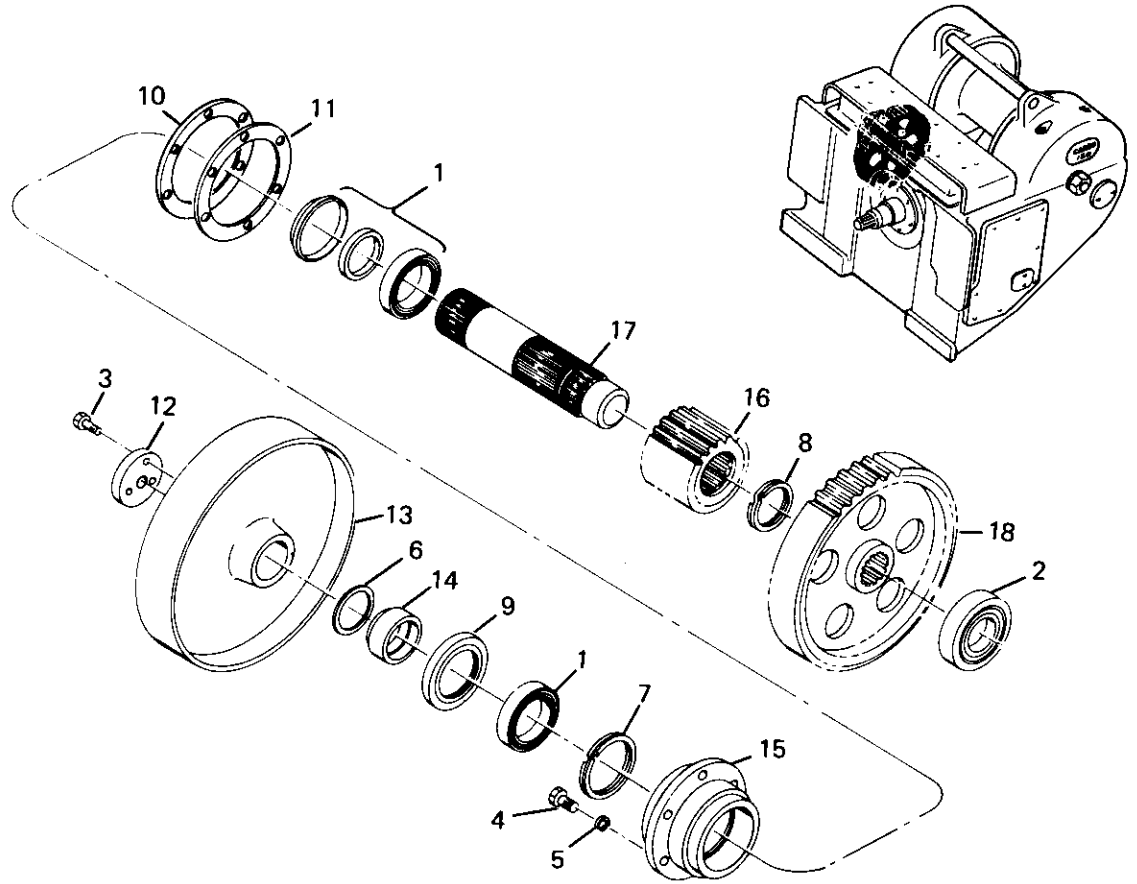

IDLER SHAFT (WITH HEAVY DUTY BRAKE ASSEMBLY) GROUP NO. 52269

| REF. | CARCO PART NO. | NAME AND DESCRIPTION | QUAN. PER UNIT |
|------|----------------|--|----------------|
| 1 | 15295 | Bearing Assembly | 1 |
| 2 | 15139 | Roller Bearing | 1 |
| 3 | 16041-1010 | Cap Screw, 5/8 UNC x 1-1/4 H.H. | 3 |
| 4 | 16047-1014 | Cap Screw, 5/8 UNC x 1-3/4 H.H. | 6 |
| 5 | 16064-10 | Washer, 5/8 | 6 |
| 6 | 16262-237 | O-Ring, NAT'L. 623015 | 1 |
| 7 | 16305-512 | Retaining Ring, SPIROLOX RS-212 | 1 |
| 8 | 16306-325 | Retaining Ring, SPIROLOX RST-118 | 1 |
| 9 | 16342-17 | Seal, NAT'L. 41592 | 1 |
| 10 | 40147 | Shim Set | 1 |
| 11 | 46232 | Gasket | 1 |
| 12 | 49031 | Retainer | 1 |
| 13 | 49014 | Brake Drum (See page 29 for Band Assembly) | 1 |
| 14 | 49015 | Sleeve | 1 |
| 15 | 49017 | Carrier | 1 |
| 16 | 49018 | Pinion | 1 |
| 17 | 49019 | Shaft | 1 |
| 18 | 44882 | Gear | 1 |

NOTE: To be used only with brake assembly 52300 on page 29.

CARCO MODEL 120-PS, PSM & PSC WINCH
 PARTS LIST SECTION—PAGE 26
 DRUM SHAFT

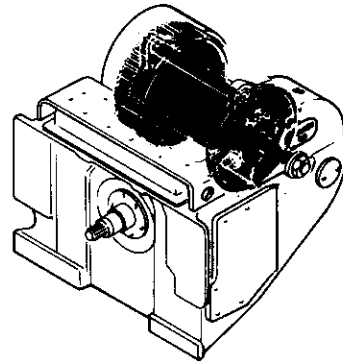
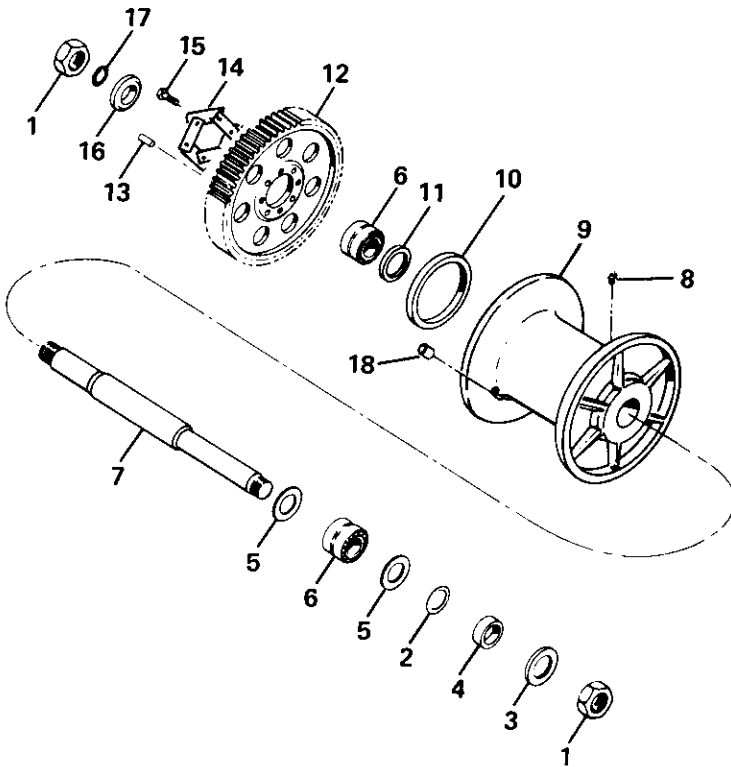

DRUM SHAFT GROUP NO. 52270

| REF. | CARCO PART NO. | NAME AND DESCRIPTION | QUAN. PER UNIT |
|-------|----------------|----------------------------------|----------------|
| 1 | 16044-44 | Nut, 2-3/4 UN Hex Jam | 2 |
| 2 | 44880 | Shim | 2 |
| 3 | 16343-33 | Oil Seal, NAT'L. 455072 | 1 |
| 4 | 40143-3 | Spacer | 1 |
| 5 | 40139 | Seal | 2 |
| 6 | { 15237 | Bearing Cone | 4 |
| | { 15238 | Cup | 2 |
| 7 | 40145 | Shaft | 1 |
| 8 | 16222-2 | Fitting, ALEMITE 1610B | 1 |
| * 9 | { 40144 | Standard Drum | 1 |
| | { 44277 | High Capacity Drum | 1 |
| 10 | 16342-12 | Oil Seal, NAT'L. 415482 | 1 |
| 11 | 16343-26 | Oil Seal, NAT'L. 455040 | 1 |
| 12 | 40137 | Gear | 1 |
| ** 13 | 45081-6 | Dowel Pin | 6 |
| 14 | 44250 | Lock | 6 |
| 15 | 16048-1620 | Cap Screw, 1 UNF x 2-1/2 H.H. | 6 |
| 16 | 44155-3 | Spacer | 1 |
| 17 | 16262-340 | O-Ring, NAT'L. 622743 | 1 |
| 18 | { 25459-3 | Ferrule for 1-1/4 Wire Rope | 1 |
| | { 25459-2 | Ferrule for 1 or 1-1/8 Wire Rope | 1 |

*Optional High Capacity Drum is standard on PSC models.

**When bull gear or cable drum is replaced, dowel holes must be drilled 1-9/64" and reamed 1.1557"/1.577" to accommodate oversize 45081-6 dowels.

CARCO MODEL 120-PS WINCH
PARTS LIST SECTION—PAGE 27
BRAKE CONTROL (SPRING APPLIED)

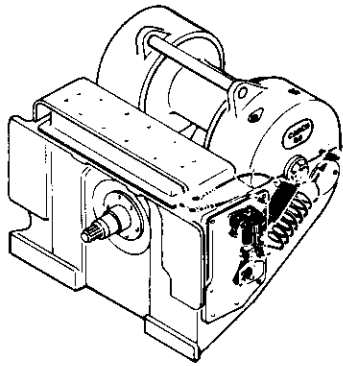

* DIAGRAM SHOWS PINS (ITEMS 7 AND 15)
IN LOCATIONS FOR OVERWIND CABLE
DRUM OPERATIONS.

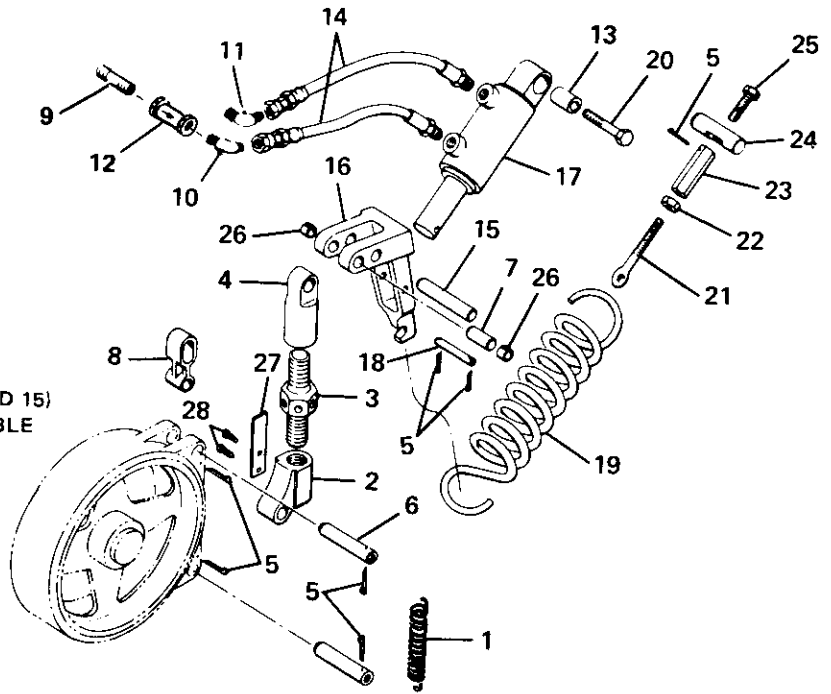

PS BRAKE CONTROL (SPRING APPLIED) GROUP NO. 52076

| REF. | CARCO PART NO. | NAME AND DESCRIPTION | QUAN. PER UNIT |
|------|----------------|-------------------------------|----------------------|
| 1 | 44107 | Spring | 1 |
| 2 | 40159-1 | Rod Nut | 1 |
| 3 | 40157 | Rod | 1 |
| 4 | 40156-1 | Rod Nut | 1 |
| 5 | 16288-420 | Cotter Pin, 1/8 x 1-1/4 | 7 |
| 6 | 44114 | Pin | 2 |
| * 7 | 32920 | Pin | 1 |
| 8 | 40119 | Link | 1 |
| 9 | 16158-412 | Nipple, 1/4 NPT x 1-1/2 | 1 |
| 10 | 16145-46 | Elbow, WTHRHD. C5405 x 6 | 1 |
| 11 | 1614566 | Elbow, WTHRHD. C5405 x 6 x 6 | 1 |
| 12 | 51278 | Flow Control Valve | 1 |
| 13 | 46077-2 | Sleeve | 2 |
| 14 | 44118-17 | Hose | 1 |
| * 15 | 32919 | Pin | 1 |
| 16 | 41361 | Arm | 1 |
| 17 | 51279 | Cylinder (see page 31) | 1 |
| 18 | 40134 | Pin | 1 |
| 19 | 40155 | Spring | 1 |
| 20 | 16047-1236 | Cap Screw, 3/4 UNC x 5 H.H. | 1 |
| 21 | 44684 | Eye Bolt | 1 |
| 22 | 16043-8 | Nut, 1/2 UNC Hex Jam | 1 |
| 23 | 40174 | Nut | 1 |
| 24 | 40175 | Pin | 1 |
| 25 | 44752 | Screw | 1 |
| 26 | 44687-1 | Spacer | 2 |
| 27 | 44806 | Spring | 1 |
| 28 | 16055-5 | Drive Screw, #10 x 3/8 Type U | 2 |

NOTE: See page 4 for control stand group.

CARCO MODEL 120-PS/IB WINCH
PARTS LIST SECTION—PAGE 28
BRAKE CONTROL 2 IN 1

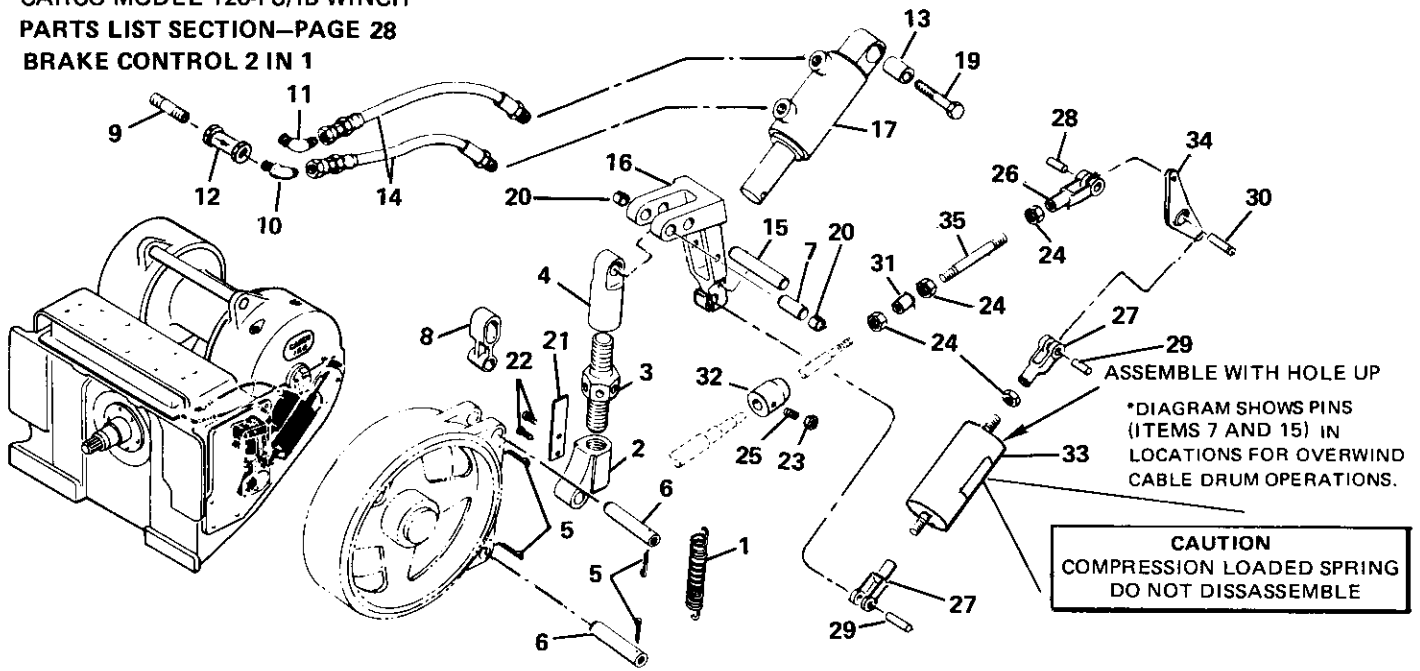

PS BRAKE CONTROL (WITH 2 IN 1 INCHING BRAKE) GROUP NO. 52078

| REF. | CARCO PART NO. | NAME AND DESCRIPTION | QUAN. PER UNIT |
|------|----------------|---|----------------|
| 1 | 44107 | Spring | 1 |
| 2 | 40159-1 | Rod Nut | 1 |
| 3 | 40157 | Rod | 1 |
| 4 | 40156-1 | Rod Nut | 1 |
| 5 | 16288-420 | Cotter Pin, 1/8 x 1-1/4 | 7 |
| 6 | 44114 | Pin | 2 |
| * 7 | 32920 | Pin | 1 |
| 8 | 40119 | Link | 1 |
| 9 | 16158-412 | Nipple, 1/4 NPT x 1-1/2 | 1 |
| 10 | 16145-46 | Elbow, WTHRD. C5405 x 6 | 1 |
| 11 | 16145-66 | Elbow, WTHRD. C5405 x 6 x 6 | 1 |
| 12 | 51278 | Flow Control Valve | 1 |
| 13 | 46077-2 | Sleeve | 1 |
| 14 | 44118-17 | Hose | 2 |
| * 15 | 32919 | Pin | 1 |
| 16 | 49426-20 | Arm | 1 |
| 17 | 51279 | Cylinder (see page 31) | 1 |
| 18 | 40134 | Pin | 1 |
| 19 | 16047-1236 | Cap Screw, 3/4 UNC x 5 H.H. | 1 |
| 20 | 44687-1 | Spacer | 2 |
| 21 | 44806 | Spring | 1 |
| 22 | 16055-5 | Drive Screw, 1/2" x 3/8 Type U | 2 |
| 23 | 16043-6 | Nut, 3/8 UNC Hex Jam | 1 |
| 24 | 16044-6 | Nut, 3/8 UNF Hex Jam | 3 |
| 25 | 16056-620 | Set Screw, 3/8 UNC x 1-1/4 Hex Soc. Cp. Pt. | 1 |
| 26 | 16245-6 | Yoke, CLEVELAND 2708-4A | 1 |
| 27 | 16245-8 | Yoke, CLEVELAND 2708-6A | 2 |
| 28 | 16246-6 | Yoke Pin Assembly, CLEVELAND 2708-1/2-4A | 1 |
| 29 | 16246-8 | Yoke Pin Assembly, CLEVELAND 2708-1/2-6A | 2 |
| 30 | 16295-2456 | Spring Pin, C.E.M.CO. 750-3500-H-B-K | 1 |
| 31 | 44013 | Coupling | 1 |
| 32 | 45351-3 | Anchor | 1 |
| 33 | 49420-20 | Spring Assembly | 1 |
| 34 | 49423 | Lever | 1 |
| 35 | 49424 | Rod | 1 |

NOTE: See page 5 for control stand group.

CARCO MODEL 120-PSC WINCH
PARTS LIST SECTION—PAGE 29
BRAKE CONTROL (HEAVY DUTY)

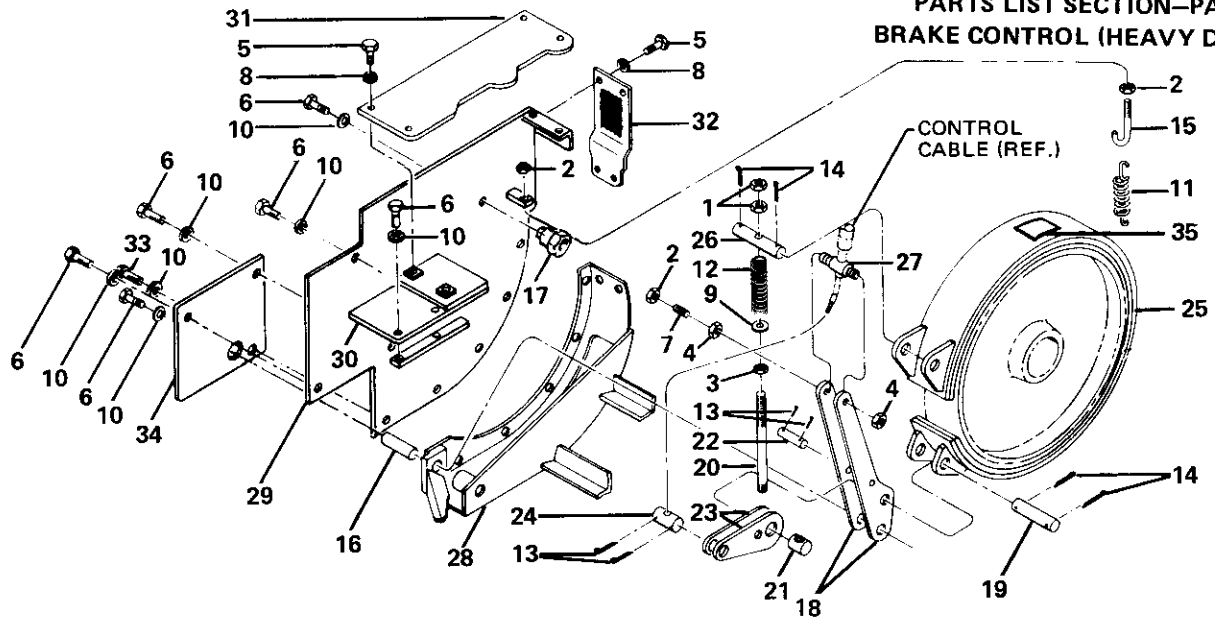

PS BRAKE CONTROL (WITH HEAVY DUTY BRAKE ASSEMBLY) GROUP NO. 52300

| REF. | CARCO PART NO. | NAME AND DESCRIPTION | QUAN. PER UNIT |
|------|----------------|--|----------------|
| 1 | 16031-8 | Nut, 1/2 UNC Hex | 2 |
| 2 | 16043-6 | Jam Nut, 3/8 UNC Hex | 3 |
| 3 | 16043-8 | Jam Nut, 1/2 UNC Hex | 1 |
| 4 | 16043-14 | Jam Nut, 7/8 UNC Hex | 2 |
| 5 | 16047-810 | Cap Screw, 1/2 UNC x 1-1/4 H.H. | 7 |
| 6 | 16047-1010 | Cap Screw, 5/8 UNC x 1-1/4 H.H. | 11 |
| 7 | 16056-628 | Set Screw, 3/8 UNC x 1-3/4 Hex Soc. Hd. | 1 |
| 8 | 16063-8 | Washer, 1/2 | 7 |
| 9 | 16064-8 | Washer, 1/2 | 1 |
| 10 | 16064-10 | Washer, 5/8 | 12 |
| 11 | 16240-7 | Spring | 1 |
| 12 | 16240-9 | Spring | 1 |
| 13 | 16288-416 | Cotter Pin, 1/8 x 1 | 4 |
| 14 | 16288-628 | Cotter Pin, 3/16 x 1-3/4 | 4 |
| 15 | 39927-1 | Bolt | 1 |
| 16 | 39927-1 | Bolt | 1 |
| 17 | 49016-120 | Nut (Drum Shaft Nut) | 1 |
| 18 | 49021 | Link | 2 |
| 19 | 49022 | Pin | 1 |
| 20 | 49023 | Rod | 1 |
| 21 | 49024 | Pin | 1 |
| 22 | 49025 | Pin | 1 |
| 23 | 49026 | Lever | 2 |
| 24 | 49027 | Pin | 1 |
| 25 | 49028 | Brake Band Assembly (See page 25 for Brake Drum) | 1 |
| 26 | 49029 | Pin | 1 |
| 27 | 49030 | Pin | 1 |
| 28 | 49050 | Shroud | 1 |
| 29 | 49301 | Brake Guard Assembly | 1 |
| 30 | 49302 | Bracket | 1 |
| 31 | 49303 | Cover | 1 |
| 32 | 49304 | Guard | 1 |
| 33 | 16047-1014 | Cap Screw, 5/8 UNC x 1-3/4 H.H. | 1 |
| 34 | 51610 | Cover | 1 |
| 35 | 51955 | Asbestos Warning Plate | 1 |

NOTE: To be used only with idler shaft assembly 52269 page 25.

See page 6 for control stand group.

CARCO MODEL 120-PSM & PSC WINCH
 PARTS LIST SECTION—PAGE 30
 BRAKE CONTROL (MANUAL)

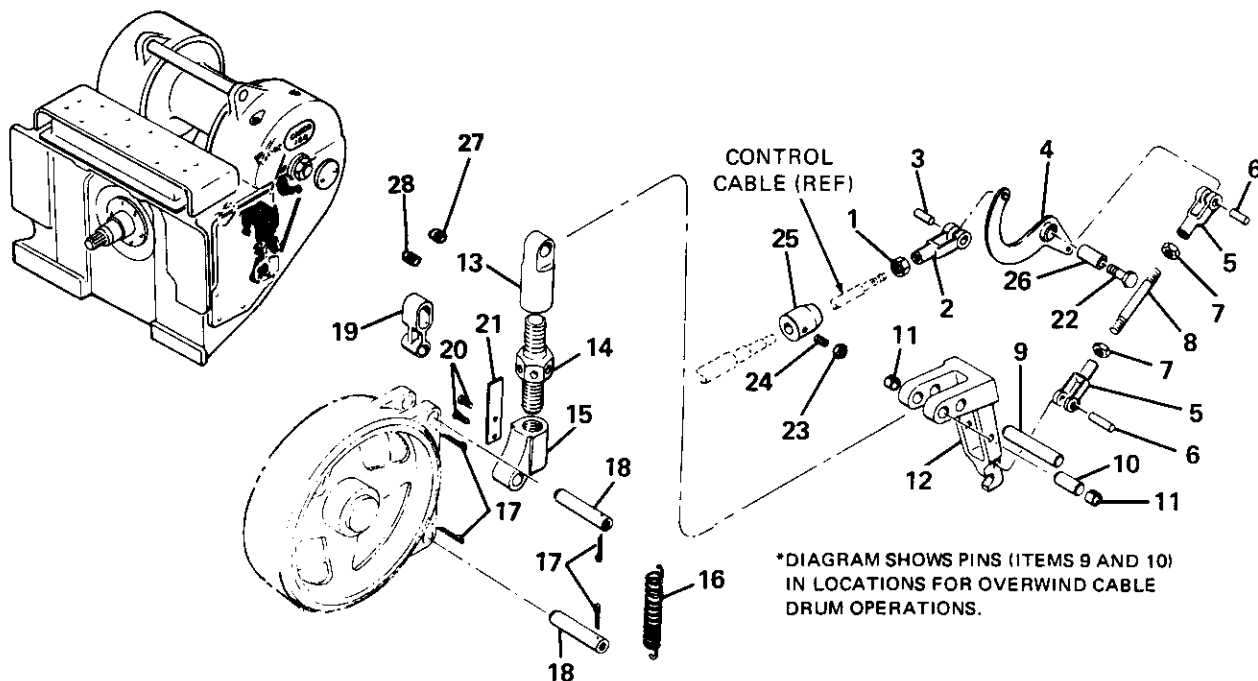

BRAKE CONTROL (MANUAL) GROUP NO. 52077

| REF. | CARCO PART NO. | NAME AND DESCRIPTION | QUAN. PER UNIT |
|------|----------------|-------------------------------------|----------------|
| 1 | 16044-6 | Nut, 3/8 UNF Hex Jam | 1 |
| 2 | 16245-6 | Yoke, Cleve. 2708-4A | 1 |
| 3 | 16246-6 | Pin, Cleve. 2708-1/2-4A | 1 |
| 4 | 44990 | Lever | 1 |
| 5 | 16245-8 | Yoke, Cleve. 2708-6A | 2 |
| 6 | 16246-8 | Pin, Cleve. 2708-1/2-6A | 2 |
| 7 | 16044-8 | Nut, 1/2 UNF Hex Jam | 2 |
| 8 | 37629-5 | Stud | 1 |
| 9 | 32919 | Pin | 1 |
| 10 | 32920 | Pin | 1 |
| 11 | 44687-1 | Spacer | 2 |
| 12 | 41361 | Arm | 1 |
| 13 | 40156-1 | Rod Nut | 1 |
| 14 | 40157 | Rod | 1 |
| 15 | 40159-1 | Rod Nut | 1 |
| 16 | 44107 | Spring | 1 |
| 17 | 16288-420 | Cotter Pin, 1/8 x 1-1/4 | 4 |
| 18 | 44114 | Pin | 2 |
| 19 | 40119 | Brake Link | 1 |
| 20 | 16055-5 | Drive Screw, # 10 x 3/8 Type U | 2 |
| 21 | 44806 | Spring | 1 |
| 22 | 16047-1236 | Cap Screw, 3/4 UNC x 5 H.H. | 1 |
| 23 | 16043-6 | Nut, 3/8 UNC Hex Jam | 1 |
| 24 | 16056-620 | Set Screw, 3/8 UNC x 1-1/4 Hex Soc. | 1 |
| 25 | 45351-3 | Anchor | 1 |
| 26 | 46077-2 | Sleeve | 1 |
| 27 | 16169-6 | Plug, 3/8 NPT Sq. Hd. | 1 |
| 28 | 16169-4 | Plug, 1/4 NPT Sq. Hd. | 1 |

NOTE: See page 7 for control stand group.

CARCO MODEL 120-PS WINCH
PARTS LIST SECTION—PAGE 31
BRAKE CYLINDER

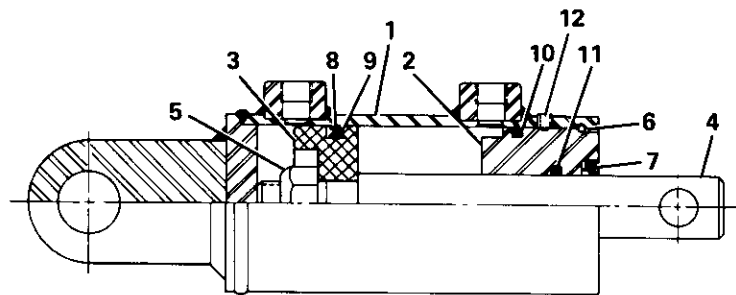

MANUFACTURER: CROSS
CARCO PART NO. 51301
CROSS PART NO.: 026255

BRAKE CYLINDER NO. 51279

| REF. | CARCO PART NO. | NAME AND DESCRIPTION | QUAN. PER UNIT |
|------|----------------|-----------------------------------|----------------------|
| ** 1 | | Tube Assembly | 1 |
| 2 | 16280-2 | Head, CROSS 1C3243 | 1 |
| 3 | 16280-15 | Piston, CROSS 3C7800 | 1 |
| 4 | 16280-4 | Rod, CROSS 1C3282 | 1 |
| 5 | 16280-5 | Nut, CROSS 2A0246-12 | 1 |
| 6 | 16280-6 | Retaining Ring, CROSS 2A0462-250 | 1 |
| * 7 | 16280-7 | Wiper, CROSS 2A0773-816 | 1 |
| * 8 | 16334-1 | Seal, C/R 710087 | 1 |
| * 9 | 16301-1 | Back-up Washer, C/R 451069 | 1 |
| * 10 | 16262-228 | O-Ring, NAT'L 623006 | 1 |
| * 11 | 16262-214 | O-Ring, NAT'L 622719 | 1 |
| * 12 | 16054-404 | Set Screw, 1/4 UNC x 1/4 Hex Soc. | 2 |
| * * | 46241 | Repair Kit | 1 |

*Items 7, 8, 9, 10 and 11 are included in 46241 repair kit.

**Not a spares item, order 51279 cylinder assembly.

CARCO MODEL 120-PS, PSM & PSC WINCH
 PARTS LIST SECTION—PAGE 32
 PRESSURE GAUGE

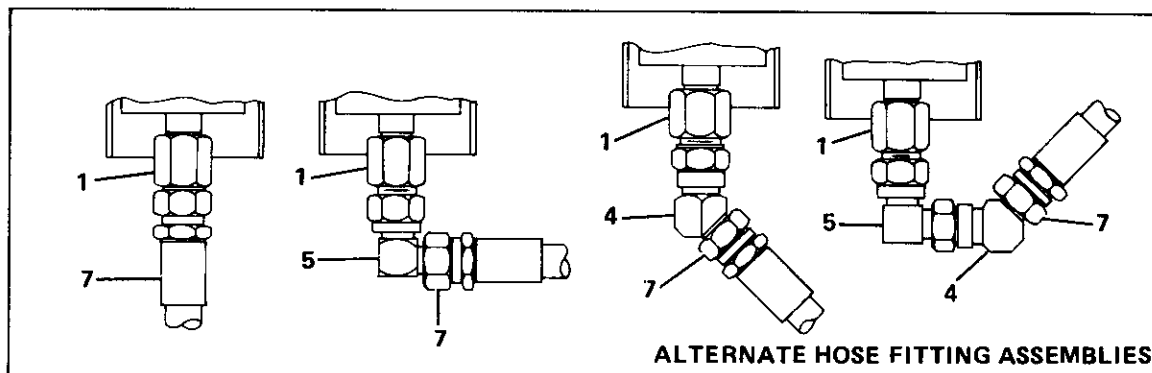
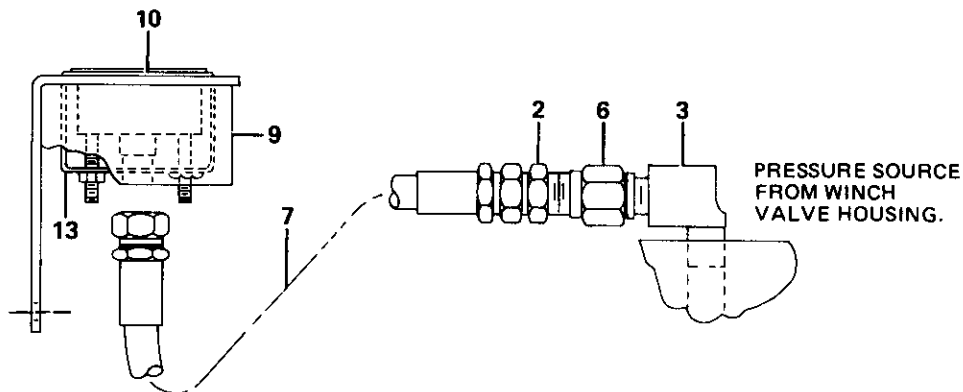

PRESSURE GAUGE KIT NO. 48700-120

| REF. | CARCO PART NO. | NAME AND DESCRIPTION | QUAN. PER UNIT | |
|------|----------------|-------------------------------|---|---|
| 1 | 16116-44 | Adapter, WTHRD. C5255 x 4 x 4 | 1 | |
| *** | 2 | 16129-44 | Connector, WTHRD. C5205 x 4 x 4 (See Below) | 1 |
| *** | 3 | 16171-44 | Elbow, WTHRD. 3400 x 4 (See Below) | 1 |
| 4 | 16184-44 | Union, WTHRD. C5356 x 4 | 1 | |
| 5 | 16185-44 | Union, WTHRD. C5506 x 4 | 1 | |
| *** | 6 | 16362-44 | Snubber, CHEMIQUIP 25B-D (See Below) | 1 |
| * | 7 | 44921-120 | Hose Assembly | 1 |
| 8 | 45101 | Tag, Instruction—Not Shown | 1 | |
| 9 | 48687 | Bracket | 1 | |
| 10 | 48693-1 | Gauge | 1 | |
| ** | 11 | 48712 | Sheet, Instruction—Not Shown | 1 |
| ** | 12 | 48700 | Gauge Kit Print — Not Shown | 1 |
| 13 | 49121 | Bracket | 1 | |

*48700 kit can be ordered, which is without item 7.

**Items 8, 11 and 12 are included in gauge kit.

***Items 2, 3 and 6 are also shown on control valve, page

CARCO MODEL 120-PS WINCH
PARTS LIST SECTION—PAGE 33
CONTROL STAND

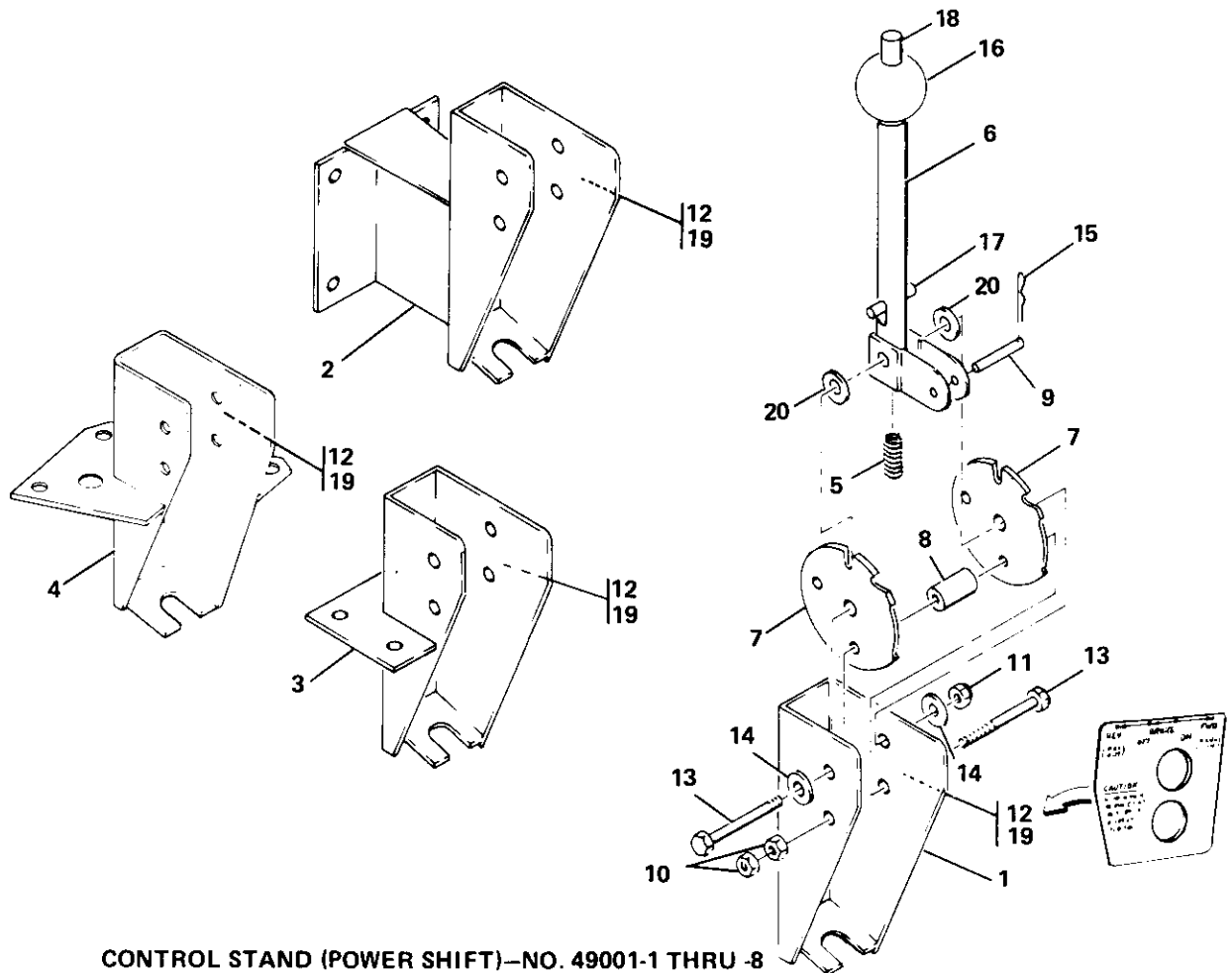

CONTROL STAND (POWER SHIFT)—NO. 49001-1 THRU -8

| REF. | CARCO PART NO. | NAME AND DESCRIPTION | CONTROL STAND GROUP NO'S 49001-1 THRU 49001-8 | | | | | | | |
|------|----------------|--------------------------------------|--|------------|------------|------------|------------|------------|------------|------------|
| | | | QTY. -1 | QTY. -2 | QTY. -3 | QTY. -4 | QTY. -5 | QTY. -6 | QTY. -7 | QTY. -8 |
| 1 | 49002-1 | Housing | 1 | | | | 1 | | 1 | |
| 2 | 49002-2 | Housing | | 1 | | | | | 1 | 1 |
| 3 | 49002-3 | Housing | | | 1 | | | | | |
| 4 | 49002-4 | Housing | | | | 1 | | | | |
| 5 | 41403 | Spring | 1 | 1 | 1 | 1 | 1 | 1 | 1 | 1 |
| * | 6 | 49003 Lever Assy. | 1 | 1 | 1 | 1 | 1 | 1 | 1 | 1 |
| | 7 | 49007 Lock Plate | 2 | 2 | 2 | 2 | 2 | 2 | 2 | 2 |
| | 8 | 49804-3 Spacer | 1 | 1 | 1 | 1 | 1 | 1 | 1 | 1 |
| | 9 | 49010 Pin | 1 | 1 | 1 | 1 | 1 | 1 | 1 | 1 |
| 10 | 16033-6 | Nut, 3/8 UNC Hex | 2 | 2 | 2 | 2 | 2 | 2 | 2 | 2 |
| 11 | 16039-66 | Lock Nut, ESNA 21NE-066 | 1 | 1 | 1 | 1 | 1 | 1 | 1 | 1 |
| 12 | 49314 | Shift Instruction Plate | 1 | 1 | 1 | 1 | | | | |
| 13 | 16047-620 | Cap Screw, 3/8 UNC x 2-1/2 H.H. | 2 | 2 | 2 | 2 | 2 | 2 | 2 | 2 |
| 14 | 16064-6 | Washer, 3/8 | 2 | 2 | 2 | 2 | 2 | 2 | 2 | 2 |
| 15 | 16381-13 | Hitch Pin, WESTERN WIRE WW-13 | 1 | 1 | 1 | 1 | 1 | 1 | 1 | 1 |
| * | 16 | 41404 Ball | 1 | 1 | 1 | 1 | 1 | 1 | 1 | 1 |
| * | 17 | 16294-824 Spring Pin, 1/4 x 1-1/2 | 1 | 1 | 1 | 1 | 1 | 1 | 1 | 1 |
| * | 18 | 49004 Push Rod | 1 | 1 | 1 | 1 | 1 | 1 | 1 | 1 |
| | 19 | 49314-3 Shift Instruction Plate | | | | | | 1 | | |
| 20 | 16009-6 | Thrust Bearing, BUNTING TW 37 | 2 | 2 | 2 | 2 | 2 | 2 | 2 | 2 |

*Items 16, 17, 18 are included in item 6.

NOTE: See page 24 for PS brake control group used with these stands.

CARCO MODEL 120-PSC & PSM WINCH
 PARTS LIST SECTION—PAGE 34
 CONTROL STAND, MANUAL AND HEAVY DUTY BRAKE

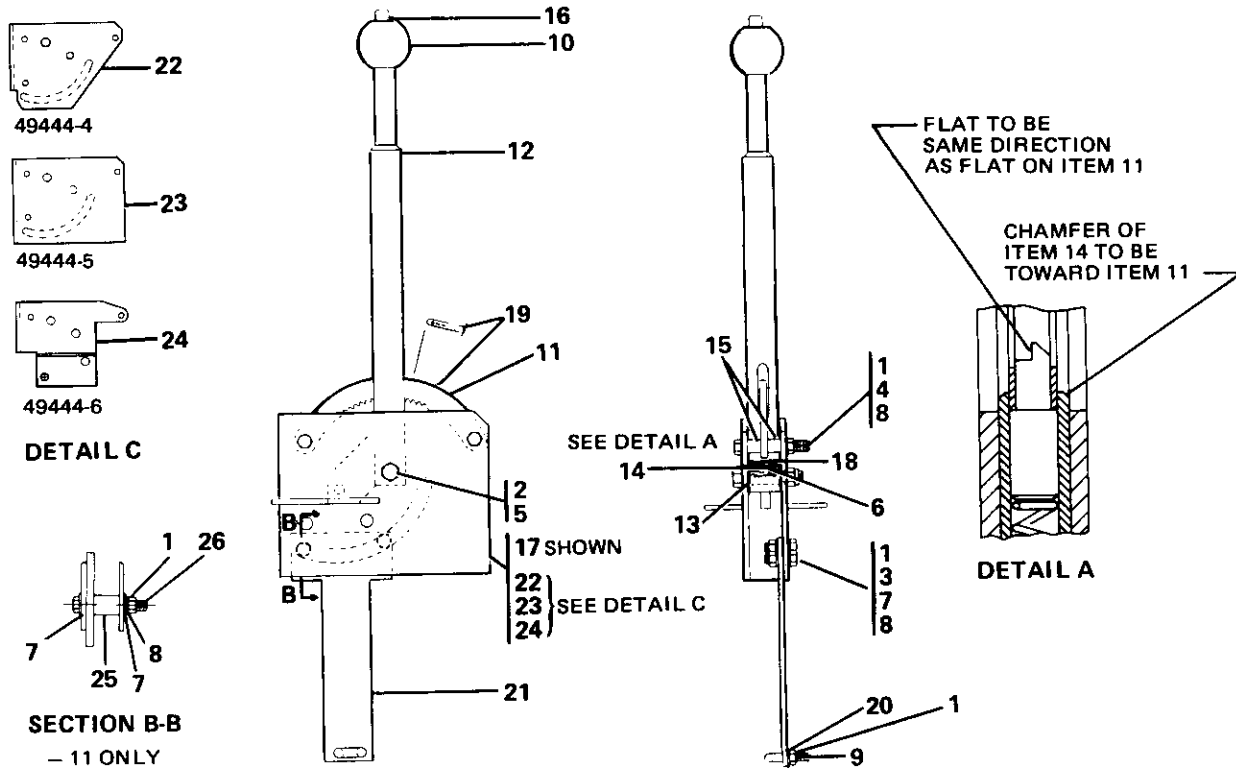

BRAKE STAND - NO. 49434 - 7 THRU - 11

| REF. | CARCO PART NO. | NAME AND DESCRIPTION | BRAKE STAND GROUP NO. | | | |
|------|----------------|---------------------------------|-----------------------|------------------|------------------|-------------------|
| | | | QUANTITY 49434-7 | QUANTITY 49434-8 | QUANTITY 49434-9 | QUANTITY 49434-11 |
| 1 | 16033-6 | Nut, 3/8 UNC Hex | 4 | 4 | 4 | 4 |
| 2 | 16039-83 | Lock Nut, ESNA 21NE-083 | 1 | 1 | 1 | |
| 3 | 16047-608 | Cap Screw, 3/8 UNC x 1 H.H. | 2 | 2 | 2 | |
| 4 | 16047-620 | Cap Screw, 3/8 UNC x 2-1/2 H.H. | 2 | 2 | 2 | 2 |
| 5 | 16047-818 | Cap Screw, 1/2 UNC x 2-1/4 H.H. | 1 | 1 | 1 | 1 |
| 6 | 16064-3 | Washer, No. 10 | 1 | 1 | 1 | 1 |
| 7 | 16064-6 | Washer, 3/8 | 2 | 2 | 2 | 4 |
| 8 | 16067-6 | Lock Washer, 3/8 | 4 | 4 | 4 | 4 |
| 9 | 16398-4 | U-Bolt, CABLECRAFT 161-010-4 | 1 | 1 | 1 | 1 |
| 10 | 41404 | Ball | 1 | 1 | 1 | 1 |
| 11 | 50627 | Sector | 1 | 1 | 1 | 1 |
| 12 | 49435 | Handle | 1 | 1 | 1 | 1 |
| 13 | 49436 | Washer | 2 | 2 | 2 | 2 |
| 14 | 49437 | Bushing | 1 | 1 | 1 | 1 |
| 15 | 49438 | Spacer | 4 | 4 | 4 | 4 |
| 16 | 50629 | Rod | 1 | 1 | 1 | 1 |
| 17 | 49444-3 | Housing | 1 | | | |
| 18 | 49445 | Spring | 1 | 1 | 1 | 1 |
| 19 | 49446 | Plate | 1 | 1 | 1 | 1 |
| 20 | 16067-4 | Lock Washer, 1/4 | 2 | 2 | 2 | 2 |
| 21 | 50099 | Arm | 1 | 1 | 1 | 1 |
| 22 | 49444-4 | Housing | | | 1 | |
| 23 | 49444-5 | Housing | | 1 | | |
| 24 | 49444-6 | Housing | | | | 1 |
| 25 | 48692-615 | Spacer | | | | 2 |
| 26 | 16047-618 | Cap Screw, 3/8 UNC x 2-1/4 H.H. | | | | 1 |

*See page 29 & 30 for brake control group used with these stands.

CARCO MODEL 120-PS/1B & PSC WINCH
PARTS LIST SECTION—PAGE 35
CONTROL STAND, WITH INCHING BRAKE

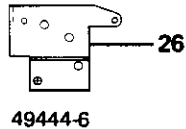
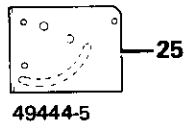
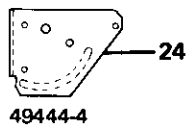

DETAIL C

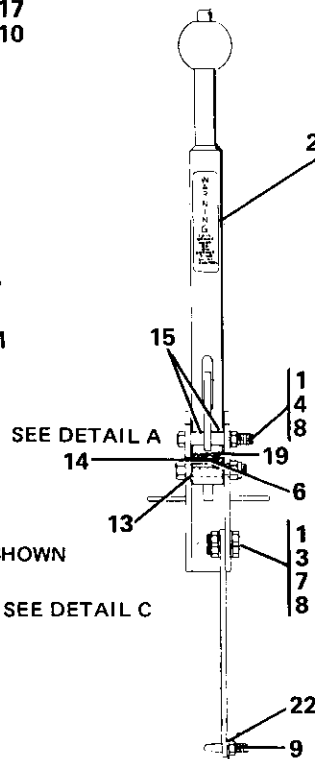
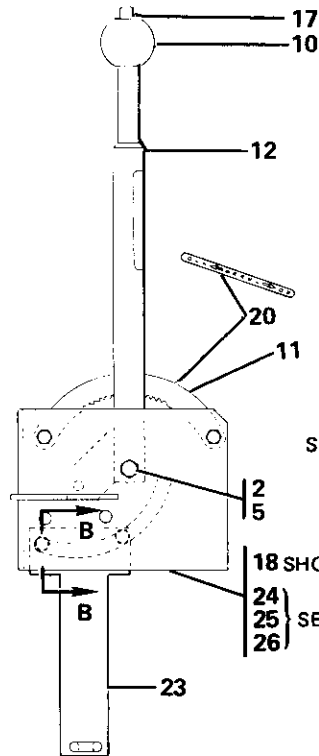
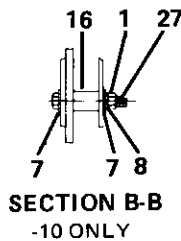

WARNING
THIS BRAKE MUST BE ON BEFORE USING SHIFT CONTROL

FLAT TO BE SAME SAME DIRECTION AS FLAT ON ITEM 11
CHAMFER OF ITEM 14 TO BE TOWARD ITEM 11

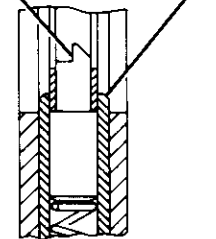

2 IN 1 INCHING BRAKE STAND—NO. 49434 — 4 THRU — 10

| REF. | CARCO PART NO. | NAME AND DESCRIPTION | BRAKE STAND GROUP NO. | | | |
|------|----------------|----------------------------------|-----------------------|---------------------|---------------------|----------------------|
| | | | QUANTITY 49434-4 | QUANTITY 49434-5 | QUANTITY 49434-6 | QUANTITY 49434-10 |
| 1 | 16033-6 | Nut, 3/8 UNC Hex | 4 | 4 | 4 | 4 |
| 2 | 16039-83 | Lock Nut, ESNA 21NE-083 | 1 | 1 | 1 | |
| 3 | 16047-608 | Cap Screw, 3/8 UNC x 1 H.H. | 2 | 2 | 2 | |
| 4 | 16047-620 | Cap Screw, 3/8 UNC x 2-1/2 H.H. | 2 | 2 | 2 | 2 |
| 5 | 16047-818 | Cap Screw, 1/2 UNC x 2-1/4 H.H. | 1 | 1 | 1 | 1 |
| 6 | 16064-3 | Washer, No. 10 | 1 | 1 | 1 | 1 |
| 7 | 16064-6 | Washer, 3/8 | 2 | 2 | 2 | 4 |
| 8 | 16067-6 | Lock Washer, 3/8 | 4 | 4 | 4 | 4 |
| 9 | 16398-4 | U-Bolt, CABLECRAFT 161-010-4 | 1 | 1 | 1 | 1 |
| 10 | 41404 | Ball | 1 | 1 | 1 | 1 |
| 11 | 50627 | Sector | 1 | 1 | 1 | 1 |
| 12 | 49435 | Handle | 1 | 1 | 1 | 1 |
| 13 | 49436 | Washer | 2 | 2 | 2 | 2 |
| 14 | 49437 | Bushing | 1 | 1 | 1 | 1 |
| 15 | 49438 | Spacer | 4 | 4 | 4 | 4 |
| 16 | 48692-615 | Spacer | | | | 2 |
| 17 | 50629 | Rod | 1 | 1 | 1 | 1 |
| 18 | 49444-3 | Housing | | 1 | | |
| 19 | 49445 | Spring | 1 | 1 | 1 | 1 |
| 20 | 49446 | Plate | 1 | 1 | 1 | 1 |
| 21 | 49928 | Warning Plate | 1 | 1 | 1 | 1 |
| 22 | 16067-4 | Lock Washer, 1/4 | 2 | 2 | 2 | 2 |
| 23 | 50099 | Arm | 1 | 1 | 1 | 1 |
| 24 | 49444-4 | Housing | 1 | | | |
| 25 | 49444-5 | Housing | | | 1 | |
| 26 | 49444-6 | Housing | | | | 1 |
| 27 | 16047-618 | Cap Screws, 3/8 UNC x 2-1/4 H.H. | | | | 1 |

*See page 28 for brake control group used with these stands.

CARCO MODEL 120-PS, PSM & PSC WINCH
 PARTS LIST SECTION—PAGE 36
 FAIRLEAD

THIS FAIRLEAD IS NORMALLY FURNISHED AS A 3-ROLLER UNIT, WITH HORIZONTAL ROLLER IN TOP POSITION — IF A 4-ROLLER UNIT IS REQUIRED, AN ADDITIONAL ROLLER CAN BE SUPPLIED CONSISTING OF ITEMS LISTED IN COLUMN "A" IN PARTS LIST.

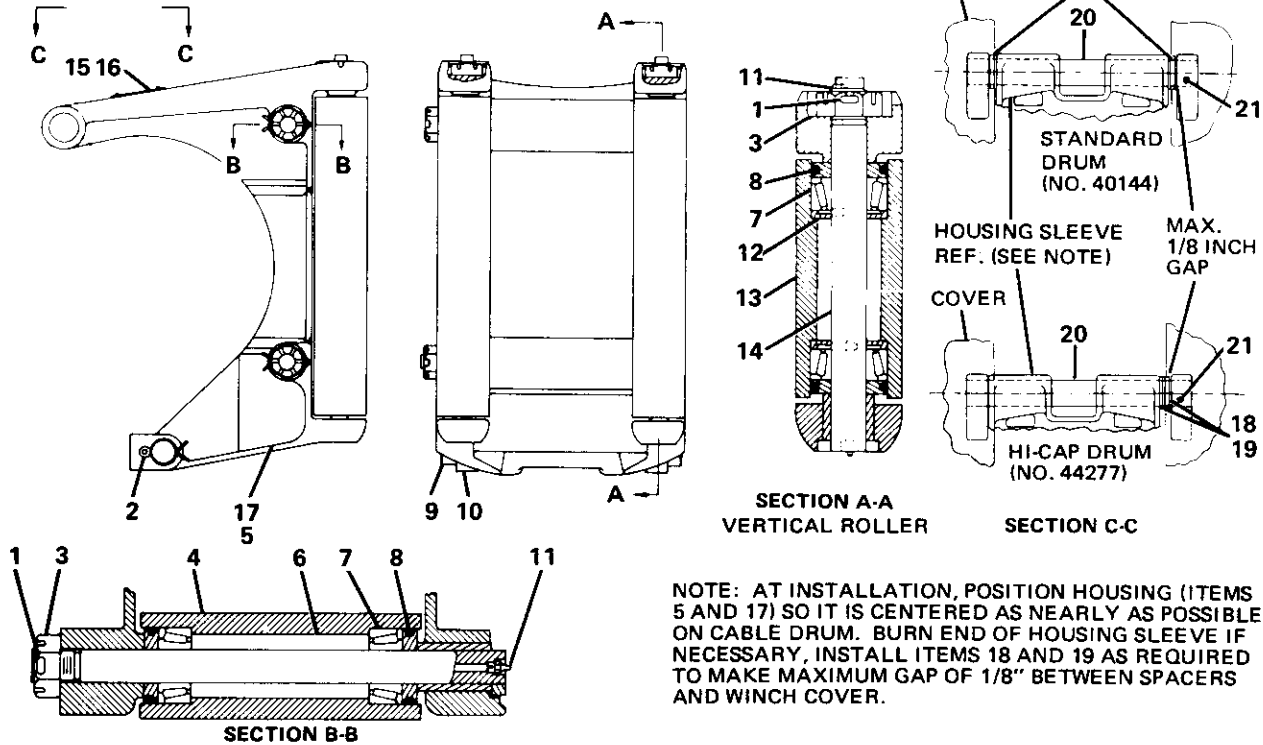

NOTE: AT INSTALLATION, POSITION HOUSING (ITEMS 5 AND 17) SO IT IS CENTERED AS NEARLY AS POSSIBLE ON CABLE DRUM. BURN END OF HOUSING SLEEVE IF NECESSARY, INSTALL ITEMS 18 AND 19 AS REQUIRED TO MAKE MAXIMUM GAP OF 1/8" BETWEEN SPACERS AND WINCH COVER.

- FAIRLEAD—PART NO. {
- 42000-30 (3 ROLLER, USE WITH STD. DRUM NO. 40144)
 - 42000-40 (4 ROLLER, USE WITH STD. DRUM NO. 40144)
 - 42000-31 (3 ROLLER, USE WITH HICAP DRUM NO. 44277)
 - 42000-41 (4 ROLLER, USE WITH HICAP DRUM NO. 44277)

| REF. | CARCO PART NO. | NAME AND DESCRIPTION | QUAN. PER UNIT | "A" |
|------|----------------|--|----------------|-----|
| 1 | 16288-1240 | Cotter Pin, 3/8 x 2-1/2 | 3 | 1 |
| 2 | 16288-1656 | Cotter Pin, 1/2 x 3-1/2 | 2 | |
| 3 | 16036-24 | Nut, TIMKEN K8111 | 3 | 1 |
| 4 | 32807 | Roller | 1 | 1 |
| 5 | 48454 | Housing (For High Capacity Drum 44277) | 1 | |
| 6 | 32806 | Shaft | 1 | 1 |
| 7 | 15235 | Brg. Cup | 6 | 2 |
| | 15178 | Brg. Cone | 6 | 2 |
| 8 | 30044 | Dust Guard | 6 | 2 |
| 9 | 30051-3 | Bar | 1 | |
| 10 | 42005 | Attaching Lug | 2 | |
| 11 | 16222-2 | Grease Fitting, ALEMITE 1610B | 5 | 1 |
| 12 | 30045 | Retainer | 4 | |
| 13 | 30705 | Roller | 2 | |
| 14 | 30701 | Shaft | 2 | |
| 15 | 16055-5 | Drive Screw, #10 x 3/8 Type U | 4 | |
| 16 | 26248 | Name Plate | 1 | |
| 17 | 42001 | Housing (For Std. Drum 40144) | 1 | |
| 18 | 49879-1 | Spacer | 1 | |
| 19 | 49879-2 | Spacer | 2 | |
| 20 | 49043-3 | Cable Guard | 1 | |
| 21 | 16288-1272 | Cotter Pin, 3/8 x 4-1/2 | 1 | |

*Welds to winch case.